

AUTOMATION OF COLOUR REMOVAL USING BIO-PROCESS IN TEXTILE WASTE WATER

¹P. Kingston Stanley and ²A. Sanjeevi Gandhi

¹Department of Electronics and Instrumentation Engineering, Karunya University, Coimbatore
kingstonstanley@karunya.edu

²Department of Electrical and Electronics Engineering, Karpagam College of Engineering, Coimbatore
sanjeevigandhi@gmail.com

³K. Suresh Kumar and ⁴S. Kalidass

³Department of Biotechnology, Karunya University, Coimbatore
sksureshkumarmanickam@gmail.com

⁴Department of Animal Sciences, Manonmiam University, Tirunelveli
kallidass@gmail.com

Abstract: Textile industry is the second polluter of clean water. The effluent from textile industries consists of a mixture of various dyes. These dyestuffs are made of complex aromatic structures which are highly recalcitrant. The dye colour in the water bodies become a major aesthetic problem along with other ecological problems. Many methods are used for dye removal process which includes chemical coagulation, flocculation, chemical oxidation, photochemical degradation, membrane filtration and aerobic and anaerobic biological degradation. These methods have certain limitations, and nothing is successful in the complete removal of dye from wastewater. The ultimate use of this methodology is to make out a high efficient process with complete automation. Metal nanoparticles are also being employed for decolourization of the textile dyes and they show promising results in comparison to other treatment methods. Instrumentation setup plays a major role in automating the process.

Key words: color removal, Nano particle, color optical sensor.

1. Introduction

In the recent times, water pollution has become a continuously increasing problem on the earth which is affecting the human and animal lives in all aspects. Due to rapid urbanization and industrialization, the level of toxic and hazardous chemicals released from various industries are causing a threat to the biotic and abiotic components of various eco-systems. Among the various industries that are causing pollution, the textile dyeing and finishing industry plays an important role. More than 100,000 commercially available dyes [16] are used in various processes of textile industry including dyeing and printing. Most of the synthetic dyestuffs which released from the textile industry poses components which are major threat to the environment because of their toxic, carcinogenic and highly recalcitrant characteristics [7], [13]. Azo dyes accounts for the majority of all the textile effluent because they are extensively used in the textile industries [10]. The colored waste water released from such industries pollutes the soil and nearby water bodies. The colored

and colloidal matter increase the turbidity of the river and sea water, which affects the light and oxygen penetration inside the water bodies which ultimately affect the aquatic ecosystem. It leads to alteration of the pH, increases the biochemical oxygen demand (BOD) and chemical oxygen demand (COD) [11]. When these colored effluents are discharged without proper treatment, it pollutes soil and ground water which causes various health hazards to human and animals. Hence, it becomes very necessary to degrade these toxic chemicals in to non-toxic products, before its release in to different water sources [9], [8].

The treatment procedures that are being followed are unable to remove recalcitrant azo dyes completely owing to the fact that they are very stable and resistant to degradation [12]. Although physical and chemical methods are currently being employed, they have their own demerits. Hence it has become inevitable for the use of other promising methods. Nanoremediation is one such method which is currently being used for the treatment of a variety of pollutants [14-15].

2. Materials and methods

2.1 Sample Dye Preparation

Red RR azo dye was obtained from a textile dyeing industry. Dye solutions of required concentration were prepared by mixing the dye powder in water.

2.2 Preparation of the Matrix

2.2.1 Encapsulation of bacteria in Alginate Beads

The efficient bacterial strain (*Aneurinibacillus aneurinilyticus*) which effectively decolorized the textile dyes was immobilized in calcium alginate beads. For immobilization, the bacterial cells were grown overnight, harvested by centrifugation at 7000 rpm for ten minutes. The pellet was washed with saline and suspended in sodium alginate. This mixture was extruded drop-wise into CaCl₂ solution, which is a cross-linking agent to form calcium alginate beads. Beads were allowed to harden in calcium chloride solution for 10-12 hours at 4°C and were then washed with saline to remove excess

amount of CaCl_2 and free cells. The diameter of the beads was found to be in the range of 2mm to 5mm. The calcium alginate beads with immobilized cells were then used for decolourization experiments. The whole procedure of immobilization was carried out under aseptic conditions.

2.2.2 Immobilization of nanoparticles on the Carrier

Carrier matrices of different pore sizes were purchased from a local supplier and were cut into uniform sizes of 1x1x1 cm. Pretreatment of the matrices were done by soaking them in a dilute hydrochloric acid solution (4%) for a period of 8 – 12 hours. All the required reagents were prepared using 40% ethanol (1.0 M Ferric chloride, 1.6 M Sodium borohydride, 0.1% Palladium acetate). Nanoparticles were then synthesized onto the matrices by the sodium borohydride reduction method. Palladium acetate was doped onto the matrices to improve the activity of the nanoparticles and were used for experiments.

2.3 Sensor Design and Calibration characteristics

2.3.1 Color sensor (TCS3200)

The TCS3103 and TCS3104 RGB Light-to-Voltage Converters combine three photodiodes with optical filters, amplifiers, and gain-switching circuitry on a single chip as shown in the pin diagram of the sensor in Fig 1. The output of each channel is a voltage that is linearly proportional to the light intensity (irradiance) on the corresponding photodiode element. Gain is switchable via a digital input pin from 1x to 4x on the TCS3104, and from 2x to 4x on the TCS3103 (as compared to 1x of TCS3104). Each channel on the device consists of a photodiode with a red, green, or blue optical filter, a current-to-voltage converter, and gain control elements.

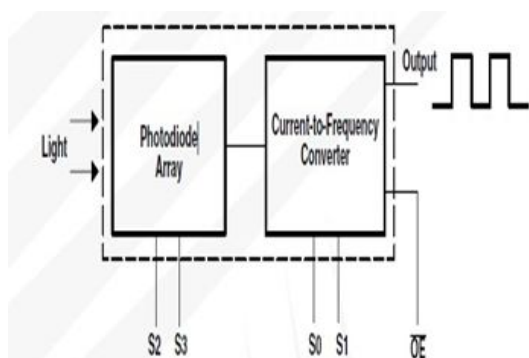

Fig. 1. Functional block diagram of the sensor

In the TCS3200, the light-to-frequency converter reads an 8 x 8 array of photodiodes. Sixteen photodiodes have blue filters, 16 photodiodes have green filters, 16 photodiodes have red filters, and 16 photodiodes are clear with no filters. The four types (colors) of photodiodes are interdigitated to minimize the effect of

non-uniformity of incident irradiance. All photodiodes of the same color are connected in parallel. Pins S2 and S3 are used to select which group of photodiodes (red, green, blue, clear) are active.

Photodiodes are 110 μm x 110 μm in size and are 134 μm centers. The output from the sensor i.e output frequency scaling can be done by setting up the S0 and S1 selection lines, the selection modes are given in the table 2. By selecting 2% of the output scaling we obtain only the 2% of the output. So for obtaining 100% output, the modes are made high by digital trainer kit.

Table 1 (Photodiode modes)

S ₂	S ₃	PHOTODIODE TYPES
L	L	RED
L	H	BLUE
H	L	CLEAR (No Filter)
H	H	GREEN

Table 2 (Output Frequency Scaling)

S ₀	S ₁	OUTPUT FREQUENCY SCALING (fo)
L	L	Power Down
L	H	2%
H	L	20%
H	H	100%

3.2 Color Sensor Calibration

Calibration is a process of finding a relation between two unknown (when the measurable quantities are not given a particular value for the amount considered or found a standard for the quantity) quantities. The sensor should be calibrated to attain the datasheet

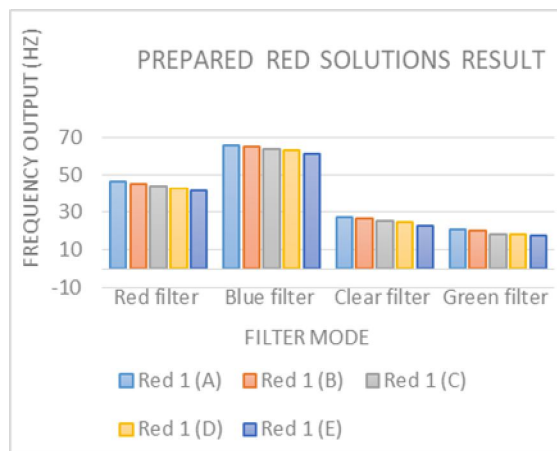

Fig. 2. Filter Mode (Red) vs Frequency

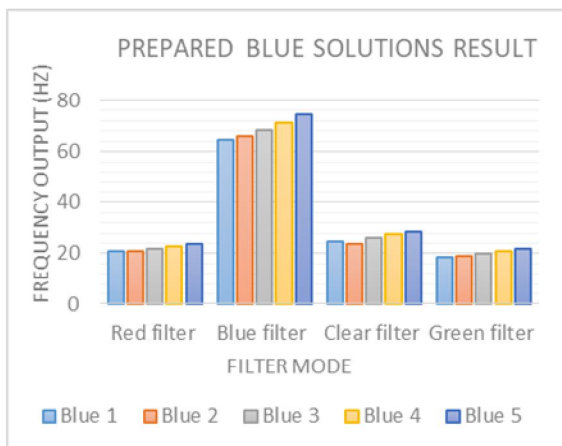

Fig. 3. Filter Mode (Blue) vs Frequency requirements. To calibrate, different concentrations of red and blue dye solutions were taken and were experimented with TCS3200 sensor and the corresponding frequency results were obtained. (Fig 2 & Fig 3). Frequency results were obtained for green filter also. And these results were helpful in identifying the suitable filter for measuring & controlling the colour removal process. After analyzing the results of these mode, blue filter shows more frequency variation than the other filter modes.

Experiments were carried out in a batch mode to find out the decolourization efficiency of the immobilized bacteria and immobilized nanoparticles. The same experiment was carried out in a closed and open loop format.

2.4 Bio-Process Setup

The Bio-Process setup was prepared with the treated PUF matrix Fig 4. The dye solution from the actuator, which is controlled by PWM signal, made to pass through the pack of PUF. The input as well the output flow rates are controlled as 20ml/min by PWM signal and burette knob respectively. The bypass valve is used to regulate the flow of dye solution through the solution flow regulator valve.

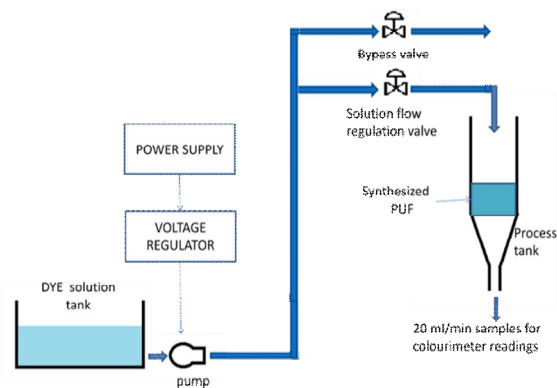

Fig. 4. Bio-Process setup

The sample dye solution is taken like a batch process and poured into the burette and let the microbes to decolorize the solution.

3. Result and Discussion

3.1 Flow rate optimization

In the process of decolourization, pump acts as final control element. In the current study, PWM signals are used to control the speed of the pump, thereby it controls the flow rate of the dye solution. For the open loop process the variable voltage regulator is enough for the purpose of control. But in the closed loop decolourization process, there will be the need of PWM signals. In the open loop test, the pump is made to operate under different voltages and the flow rates are taken down. From the observation, it is easy to find the most appropriate control voltage for the actuator to attain a certain flow rate. A flow rate of 20ml/min flow was optimized in order to obtain efficient decolourization. In the Fig 5, the graph for the input voltage Vs output flow is shown.

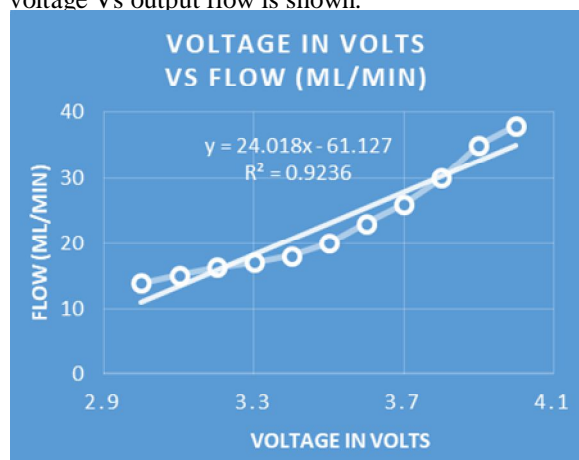

Fig. 5. Control Valve Input Voltage vs Flow Rate

3.2 Open Loop Test

The percentage degradation calculated from the colorimeter readings is compared with the standard dye solution. Thus the graph can be plotted for samples Vs the percentage of degradation. The PUF, obtained from the pretreatment process, is packed together to form a filter. The dye solution is initially poured into the reservoir tank, and the actuator is connected at the bottom of the tank. The voltage regulator is used to vary the input to the actuator, based on that the output flow from the tank will vary. The flow regulating control valve and the bypass valves are used to make sure that, if there are any sudden changes in the actuator output, it saves the process from disturbance by using bypass valve. From the Fig 6, it is evident that the decolorizing efficiency goes down after few rounds of decolourization. The shelf life of the PUF matrix in decolorizing the dye is estimated in this experiment.

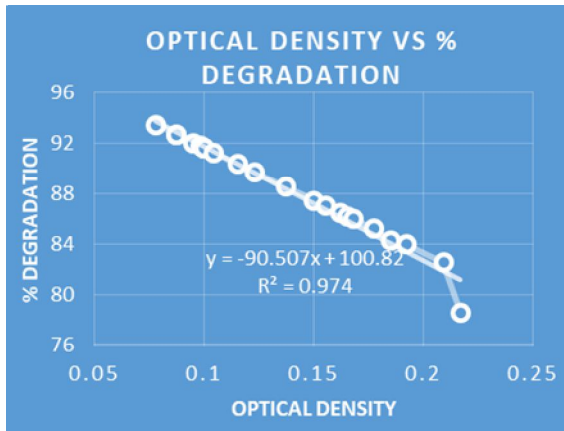

Fig. 6. Percentage of colour degradation results by PUF experiment

The alginate beads obtained from after microbial encapsulation is packed together to form a SA filter. The construction of this experimental setup is entirely different from the PUF setup, where in the outlet flow rate is maintained constant and there is no inlet continuously. The dye solution is passed in to the column and the eluates (20ml) were collected at regular time intervals (every hour). Percentage of degradation values were calculated. The efficiency of the alginate beads is proportional to the retention time of the dye solutions in the presence of the bacteria.

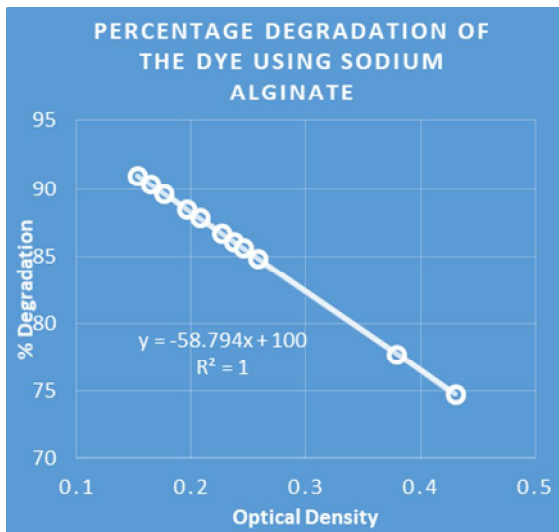

Fig. 7. Percentage colour degradation results by SA experiment

3.3 Closed Loop Test

The entire setup is run in a closed loop with a suitable controller. Fig 8 (Block Diagram), Fig 9 is the closed loop experimental setup for the decolourization process. The sensor arrangement is made in such a way that it measures the color intensity of the dye solution before and after the decolourization process. So the feedback as

well as feed forward control scheme implemented in the closed loop process ensures maximum decolorizing efficiency.

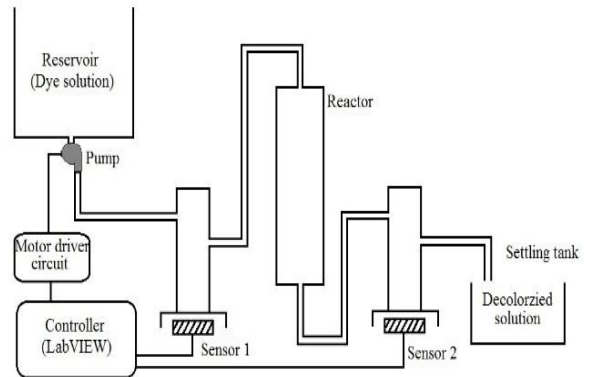

Fig. 8. Block diagram

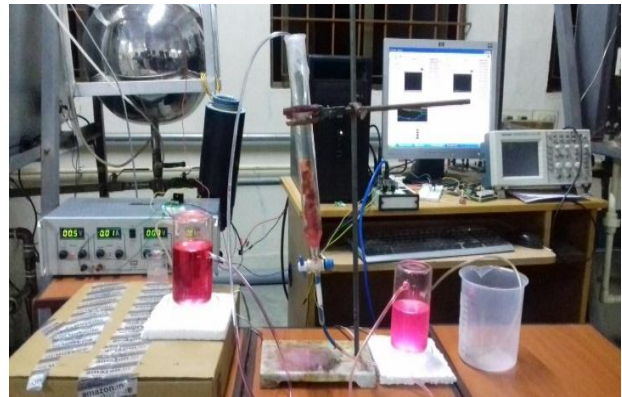

Fig. 9. Experimental setup

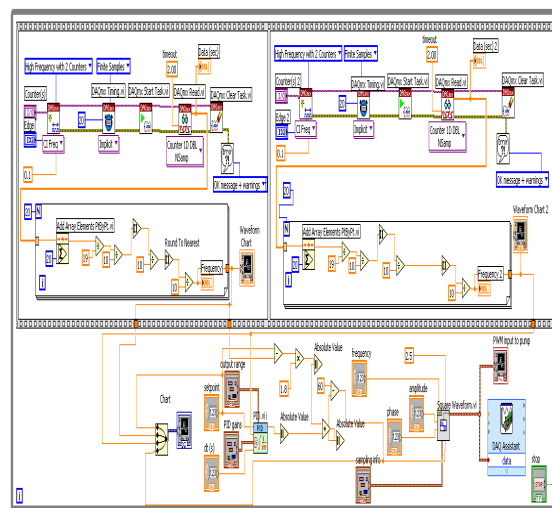

Fig. 10. Frequency counter LabVIEW program (block diagram)

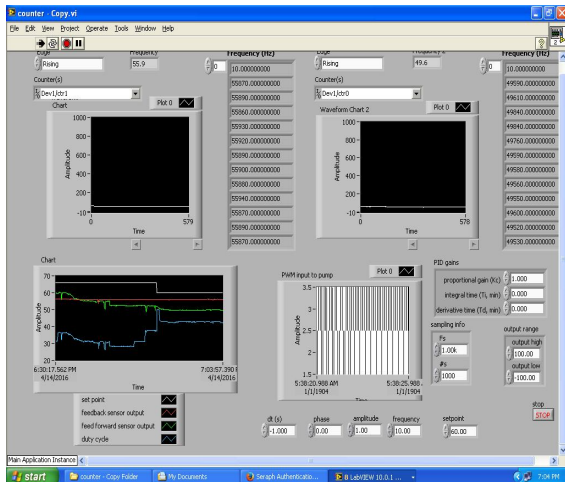

Fig 11. Frequency counter LabVIEW program (front panel)

Unlike PUF, alginate takes more time to decolorize because the microbes take more time to break the azo bonds present in the dye solution. Closed loop color removal setup shown in Fig 9, in which the feedback as well as the feed forward sensors interfaced to the real-time system. The flow rate is regulated by the pump which is driven by PWM input. The below setup is made to run as a temporary system in order to obtain the gain values for the controller. Fig 10 and Fig 11 are the Block Diagram and the Front Panel design respectively in LabVIEW Software.

4. Conclusion

In the LabVIEW program, interfacing the sensor with the pump and the reservoir is made. PID block is implemented and P controller is used in the process to adjust the flow rate by PWM circuit. The main objective of the program is to attain maximum color removal for the given solution with respect to time. The PWM should vary for every change in the feedback as well as the feedforward sensor output values. And the set point is set based on the water frequency taken from the TCS3200 sensor after calibration.

Implementation of controller design with suitable control schemes were done in this methodology. The complete controlling can be done on a system, which is operating in closed loop only by designing a controller. Flow rate is made accurate by implementing the PWM input to the pump. For that purpose, the entire process should be done inside the anaerobic chamber, which is also controlled and monitored in the effective way by LabVIEW.

Henceforth, this systemic approach towards this discipline is to give an efficient way to make out things and to automate the system. Technologies are emerging towards greater heights as such this conceptual model is made out to give an efficient way in decolorization aspect.

References

- [1].Claudinei S. Lima a,b, Karla A. Batista b, Armando Garcia Rodriguez b, Jurandir R. Souza c, Katia F. Fernandes “*Photodecomposition and colour removal of a real sample of textile wastewater using heterogeneous photocatalysis with polypyrrole*” science direct , 2015.
- [2].K S Gayathri, R. Viji, “*Removal of colour from paper mill wastewater using Neem Leaf Power*” IJEP 2015.
- [3].Kyung-Won Jung, Min-Jin Hwang, Dae-Seon Park, Kyu-Hong Ahn “*Combining fluidized metal-impregnated granular activated carbon in three-dimensional electrocoagulation system: Feasibility and optimization test of colour and COD removal from real cotton textile wastewater*” by science direct, 2 April 2015.
- [4].Amir Hajialia, Gevorg P. Pirumyanb “*Evaluation of Turbidity and Colour Removal in Treatment of Wastewater Containing Resistant Pollutants with Ozonation*” science direct on December 2014
- [5].Suphitcha Wijannarong, Sayam Aroonsrimorakot, Patana Thavipoke, Acharaporn Kumsopa and Suntree Sangjan “*Removal of Reactive Dyes from Textile Dyeing Industrial Effluent by Ozonation Process*” science direct, 2014.
- [6]. De Jager a, M.S. Sheldon a, W. Edwards b “*Colour removal from textile wastewater using a pilot-scale dual-stage MBR and subsequent RO system*” science direct on August 2014.
- [7].Chequer FMD, de Oliveira GAR, Ferraz ERA, Cardoso JC, Zanoni MVB, de Oliveira DP “*Textile dyes: dyeing process and environmental impact*” In: Gunay M (ed) Eco friendly textile dyeing and finishing. InTech Press, Croatia, (2013).
- [8].Yao, D., Chen, Z., Zhao, K., Yang, Q., & Zhang, W, “*Limitation and challenge faced to the researches on environmental risk of nanotechnology*” Procedia Environmental Sciences, 18, 149–156, (2013).
- [9]. Zhang, K., Kemp, K. C., & Chandra, V. “*Homogeneous anchoring of TiO₂ nanoparticles on graphene sheets for waste water treatment*” Materials Letters, 81, 127–130, (2012).
- [10]. Saratale GD, Saratale RG, Chang JS, Govindwar SP “*Fixed – bed decolorization of Reactive Blue 172 by Proteus vulgaris NCIM-2027 immobilized on Luffa cylindrical sponge*” Int. Biodeterior. Biodegrad. 65: 494 – 503, (2011).
- [11]. Saratale RG, Saratale GD, Kalyani DC, Chang JS, Govindawar SP “*Enhance decolorization and biodegradation of textile azo dye Scarlet R by using developed microbial consortium-GR*” Bioresource Technol. 100: 2493 -2500, (2009).
- [12]. Turhan. K. and Turgut. Z “*Decolorization of direct dye in textile wastewater by ozonation in a semibatch bubble column reactor*”, Desalination 242, 256-263, (2009).

- [13].Babu BR, Parande SR, Kumar TP “*Cotton Textile Processing: Waste Generation and Effluent Treatment*” J. Cotton Sci. 11: 141-153, (2007).
- [14].Liu. C. C., Tseng. D. H. and Wang. C. Y. “*Effects of ferrous ions on the reductive dechlorination of trichloroethylene by zero-valent iron*” Journal of Hazardous Materials 136, 706-13, 2006.
- [15].Masciangioli, Tina, Wei-Xian Zhang. “*Environmental Technologies at the Nanoscale*” Environmental Science and Technology 37(5), 102A-108A, (2003)
- [16].Fu, Y. and Viraraghavan, T., “*Fungal decolourization of dye wastewaters: a review*”, Bioresour. Technol. 79, 251-262, (2001).