

ANFIS BASED UPQC FOR POWER QUALITY IMPROVEMENT

R.Saravanan¹ & P.S.Manoharan²

¹ Christian College of Engineering and Technology, Oddanchatram, Tamilnadu, India

² Thiagarajar College of Engineering, Madurai, Tamilnadu, India

¹ rsharankiruthiga@gmail.com

Abstract: The unified power quality controller (UPQC) plays an important role in the constrained delivery of electrical power from a source to load. This paper presents Artificial Neuro Fuzzy Interference System (ANFIS) technique is proposed. This approach eliminates the total harmonic distortions (THD) efficiently, and mitigates sag, swell and reactive power compensation present in the linear and nonlinear loads. The system performance compared with Proportional Integral (PI) controller and Fuzzy Logic Controller (FLC) and also the system performance is also verified experimentally.

Keywords: Artificial Neuro Fuzzy Interference System, Fuzzy Logic Controller, Total Harmonic Distortion, Unified Power Quality Conditioner

I. Introduction

The UPQC is one of the most researched entities in the world of power electronic control of power systems. Though volumes of papers stream into the literature domain every day, it is very hard to find the real UPQC in service, even in the global electricity distribution scenario. This scenario can be attributed to the fact that the UPQC is hard to understand and it is still harder to handle this piece of equipment from the control system point of view. Many researchers have contributed to the development of the controllers associated with the UPQC. Before proposing this idea discusses a summary of the existing ideas as found in the literature at hinted in this introduction. Gyugyi et al., [1] presented a research article on the UPFC and this could be the advent of the term UPFC. However, later developments have led to the inception of a new member belonging to the set of FACTS devices and this is UPQC. With respect to the basic topology, the UPFC and the UPQC are similar. However the objectives of these two make differences in the control scheme implemented and this makes the total difference between the two.

The objectives of the UPFC are included among the other objectives of the UPQC. It can be stated that for the efficient power transaction process to work according to the commands given, we can opt for FACTS devices, especially the UPFC. But the very usage of the UPFC along with other modern power electronic gadgets and the frequent unbalanced situation in the load, we have to opt for something more than an UPFC that is the UPQC. Srinivas et al., [2] have developed a methodology for the feedback control of the UPQC using PSO technique. Though this method uses an optimization technique it needs a specialized knowledge of optimization. Moreover it could exhibit poor dynamic response because of the complicated slow nature of the control scheme which needs a computer as well. Vadirajacharya G. Kinhal et al., [3] adopted the ANN based controller and proved the usefulness of a multiple set of ANNS for controlling the individual parameter of interest. Iurie Axente et al., [4] demonstrated, with the help of a DSP, how an UPQC can be designed to handle the imperfections in power quality caused by the supply voltage side and load side a PLL less methodology has been adopted in this work. Vinod Khadkikar et al., [5] have illustrated how an optimal utilization of the UPQC can be developed and how the specific problems like voltage sag and swell can be managed using the UPQC. They have investigated the hybrid utilization of PSO alongside ANFIS. Hideaki Fujita and Hirofumi Akagi [6] in their research paper have treated the UPQC as a combination of shunt and series active filters and have viewed the control schemes

required in this perspective. Mehdi Forghani et al., [7] have used the algorithm in the classical method of parameter estimation and claimed the increased speed of response of their control strategy. Dusan Graovac et al., [8] suggested an additional shunt filter and demonstrated how it could render enhanced performance in terms of Harmonic mitigation.

Raphael J. Millnitz dos Santos et al. [9] presents simplified control technique for a dual three-phase topology of a unified power quality conditioner. Sanjib Ganguly [10] discussed sag-based design for phase-angle control for is proposed. The phase-angle shifting of load voltage is required to mitigate a given value of voltage sag is determined and provide reactive power compensation of a distribution network.

Despite the efforts of various researchers and proliferation of research articles, but the absence of popular and common usage of the UPQC in the industries, can be felt. There is a need for a simplified and comprehensive control of the UPQC that could be understood and acceptable to the industry and that is about what this paper attempts to discuss. In this paper an attempt is made to present a step by step development of a simple comprehensive control scheme. At the same time an effective control scheme for the management of the UPQC with a single ANFIS controller.

II. UPQC

The UPQC basically has two power electronic converters linked by a common DC link. These two converters engaged in the operation of the constrained power transaction process make use of four controllers that help in meeting out the constraints of power transaction.

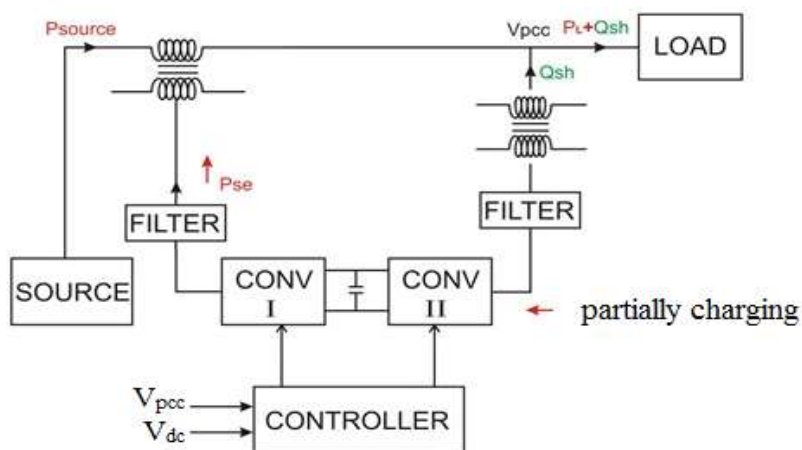

Fig. 1 Structure of Unified Power Quality Conditioner

2.1 Shunt converter

The shunt converter is a three leg three phase Graetz bridge converter with a DC side and a three phase AC side. The three phase AC side is connected across the three phase AC bus bar at the point of common coupling through a voltage transformer and a series reactor as shown in Fig. 1. A PWM generator generating synchronized switching pulses switch the six switches of the three leg shunt converter. The objectives of the shunt converter can be achieved by appropriately supplying the switching pulses. The generation of the switching pulses is governed by the three phase reference

signal that is produced by the contribution of two controllers. The control objectives of the two controllers influence the generation of the reference signal and this leads to the operation of the convertor meeting out its requirements. There are two controllers associated with the shunt converter. The shunt converter is a three leg three phase Graetz bridge converter with a DC side and a three phase AC side. The three phase AC side is connected across the three phase AC bus bar at the point of common coupling through a voltage transformer and a series reactor. [3]. A PWM generator generating synchronized switching pulses switch the six switches of the three leg shunt converter. The objectives of the shunt convertor can be achieved by appropriately supplying the switching pulses. The generation of the switching pulses is governed by the three phase reference signal that is produced by the contribution of two controllers. The control objectives of the two controllers influence the generation of the reference signal and this leads to the operation of the convertor meeting out its requirements [4]. There are two controllers associated with the shunt converter.

2.2 Reactive power Transaction

As for reactive power transaction between two nodes, A and B, connected by a reactor. it is required that the voltage at node A be higher in amplitude than that at node B such that reactive power can flow from node A to B and vice versa. While the two nodal voltages are in phase, higher reactive power transaction happens with higher difference in the nodal voltages. This leads to the conclusion that the control of the modulation index of the converter can control the AC side voltage of the converter which appears at one end of the reactor. The other end of the reactor is at the voltage level, at the point of common coupling but for the voltage transformation ratio of the step down transformer.

2.3 Injection of reactive power from the UPQC

The shunt converter has multiple objectives. It has to supply, at the required rate and time, real power to the DC link capacitor and thus maintain the voltage across this capacitor at the desired level. It is also one of the objectives of the shunt converter that it injects the required reactive power into the AC bus bar such that the sending end source is loaded with reactive power. Thus power factor at the sending end can be maintained at a higher level helping the source to serve more active loads. Apart from these the other two objectives are to reduce harmonics at the source end voltage and current objectives of the shunt controller are multifold.

2.4 Real Power Transaction

The shunt converter is associated with real power transaction in the process of maintaining the required DC voltage across the DC link capacitor. Under certain circumstances the energy stored in the DC link capacitor is to be utilized by the series converter for supplying real power to the load. Whenever this happens, the voltage across the DC link capacitor falls down and this is made up by the shunt converter by drawing the required real power from the AC bus and routing it to the DC link capacitor. Thus the shunt convertor supplies the required reactive power to the AC bus and also it routes the real power from the AC bus to the DC capacitor. The responsibility of maintenance of the constancy of the DC link voltage which is essential for supporting both reactive power through the shunt converter and real power through the series converter rests with the shunt converter.

2.5 Series converter

The series converter is also known as the Static Synchronous Series Compensator (SSSC). It is a three leg three phase Graetz bridge converter with a DC side and a three phase AC side. The three phase AC side is connected across one side of a three phase transformer and the other side of this transformer is in series with the three phase AC bus bar as shown in Fig. 1. The objectives of the SSSC are, To insert a series voltage along the AC bus bar. This series insertion of voltage at appropriate phase and magnitude can help compensate sag or swell in the bus voltage. Voltage sag

and swell can be smoothed by the SSSC such that the voltage across the load is fairly constant. The fluctuations in voltage across the load can adversely affect the power delivered to the load. Under conditions of voltage sag and swell propagated from the source side, the responsibility of maintenance of constancy of voltage across the load and hence the delivery of the required power to the load rests with the SSSC. Insertion of the compensating series voltage can be carried out only from a real power source and, as such, the DC side of the SSSC should be connected across a DC link where there is a possibility of drawing real power. In the case of UPQC the DC link is maintained at desired DC potential and the energy stored in the DC link is backed up by the STATCOM in real time. A PWM generator generating synchronized switching pulses switches the six switches of the SSSC. The objectives of the SSSC can be achieved by appropriately supplying the switching pulses. The generation of the switching pulses is governed by the three phase reference signal that is produced by the contribution of two controllers. The control objectives of the two controllers influence the generation of the reference signal and this leads to the operation of the SSSC meeting out its requirements.

2.6 Mathematical model of the UPQC

A UPQC distribution system is shown in Fig. 2. V_s is the source voltage, V_{se} is series converter voltage compensation, I_{sh} is shunt converter current compensation and V_L is the load voltage. It consist of load that supplied by a source voltage through a feeder system. Feeder impedance Z_s is a combination of R and XL. The shunt converter injects the current I_{sh} such that the source current is balanced and distortion free irrespective of I_L . The series converter and shunt converter can control the load voltage and source current. Due to the voltage distortion, the system may contain negative phase sequence and harmonic components [8]. With respect to the basic topology the UPFC and the UPQC are similar. However the objectives of these two make differences in the control scheme implemented and this makes the total difference between the two. The objectives of the UPFC are included among the other objectives of the UPQC.

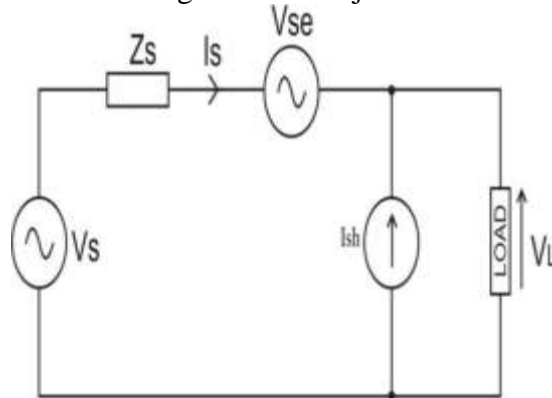

Fig. 2 UPQC Distribution system

To obtain a balance sinusoidal load voltage with fixed amplitude V , the output voltages of the series converter should be given by

$$V_{se} = (V - V_p) \sin(\theta + \theta_p) - V_n(t) - \sum_{k=2}^{\infty} V_k(t) \quad (1)$$

V_p : Positive sequence voltage amplitude fundamental frequency

θ_p : Initial phase of voltage for positive sequence

V_n : Negative sequence component

The shunt converter acts as a controlled current source and its output components should include harmonic, reactive and negative-sequence components in order to compensate these quantities in the load current, when the output current of shunt converter is kept to be equal to the component of the load as given in the following Equation (2).

$$I_L = I_p \cos(\theta + \theta_p) \sin \phi_p + I_n + \sum_{k=2}^{\infty} I_L(k) \quad (2)$$

As seen from the above equations that the harmonics, reactive and negative sequence current is not flowing into the power source. Therefore, the terminal source current is harmonic-free sinusoid and has the same phase angle as the phase voltage at the load terminal.

ϕ_p = Initial phase current for positive sequence

$$I_s = I_p \sin(\theta - \theta_p) \cos \phi_p \quad (3)$$

The source side three phase voltages, V_a , V_b and V_c are sinusoidal in nature. And these quantities are to be converted into equivalent DC quantities and then used in the controllers. The conversion of the three phase sinusoidal voltages denoted as V_{abc} into V_d , V_q and V_o in the rotating frame is known as DQ transformation or Park transformation. The vector $(V_a \ V_b \ V_c)$ can be transformed into another vector $(V_d \ V_q \ V_o)$ with the help of a transformation matrix. It can be

viewed that,

$$\begin{bmatrix} V_d \\ V_q \\ V_o \end{bmatrix} = \frac{2}{3} \begin{bmatrix} \sin \theta & \sin(\theta - \frac{2\pi}{3}) & \sin(\theta + \frac{2\pi}{3}) \\ \cos \theta & \cos(\theta - \frac{2\pi}{3}) & \cos(\theta + \frac{2\pi}{3}) \\ \frac{1}{2} & \frac{1}{2} & \frac{1}{2} \end{bmatrix} \begin{bmatrix} V_a \\ V_b \\ V_c \end{bmatrix} \quad (4)$$

$$\begin{bmatrix} V_a \\ V_b \\ V_c \end{bmatrix} = \begin{bmatrix} \sin \theta & \cos \theta & 1 \\ \sin(\theta - \frac{2\pi}{3}) & \cos(\theta - \frac{2\pi}{3}) & 1 \\ \sin(\theta + \frac{2\pi}{3}) & \cos(\theta + \frac{2\pi}{3}) & 1 \end{bmatrix} \begin{bmatrix} V_d \\ V_q \\ V_o \end{bmatrix} \quad (5)$$

The elements of the vector (V_a, V_b, V_c) and the elements of the transformation matrix are time varying but the elements of the output vector $(V_d \ V_q \ V_o)$ are not time varying. However, any change in the amplitude of either of V_a or V_b or V_c is reflected in the elements of the vector (V_d, V_q, V_o) . Park transformation is the conversion of the three phase system of voltages which are 120° displaced and varying in a sinusoidal fashion into another system of three elements which are just constants. However, in the transformed system the element V_o is zero if the three phase system is balanced. The elements V_d and V_q are orthogonal in nature such that they do not have any influence on each other. In a typical control system both V_d and V_q can be changed individually without affecting the other.

III. ANFIS controller

ANFIS system is the implementation of PI controller. Fig. 3 shows the proposed controller for unified power quality conditioner with ANFIS controller. The ANFIS controller implemented in this article is of the model described as above whose fuzzifier section comprise the input signals error (E) and change in error signal (CE) whose membership functions are selected as Gaussian membership function and are classified into seven functions namely Negative Big (NB); Negative

Small (NS); Zero (ZE); Positive Small (PS); Positive Medium (PM). As for the first step a set of four fuzzy logic controllers are designed two each for the STATCOM and the SSSC respectively.

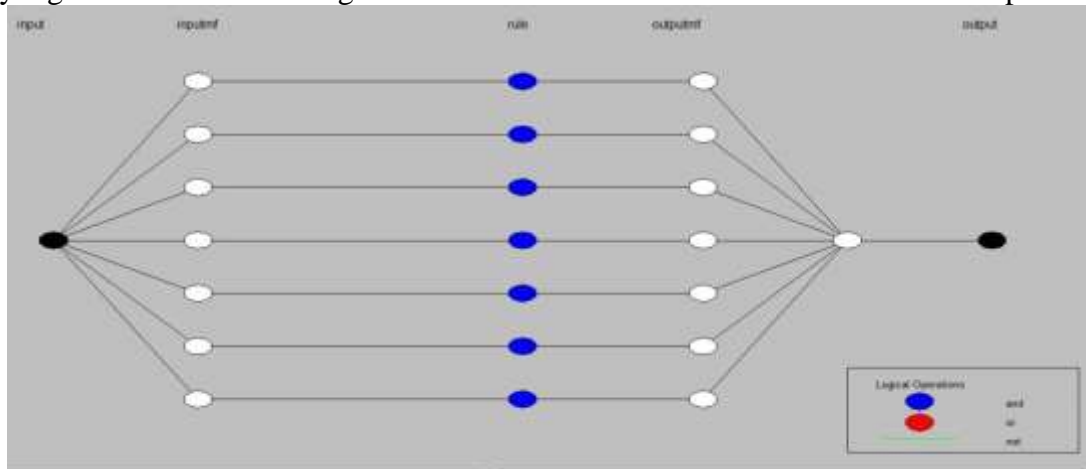

Fig. 3 ANFIS structure

The ANFIS structure of is shown above. The ANFIS structure used here have 7 rules. The rules are created by using one input. One input is DC link error Voltage and output is regulated DC output voltage. From membership function plots of both inputs, rules are created. The fuzzy inference system (FIS) is shown in figure 4(a) and membership function plots used here is shown in Figure 4(b).

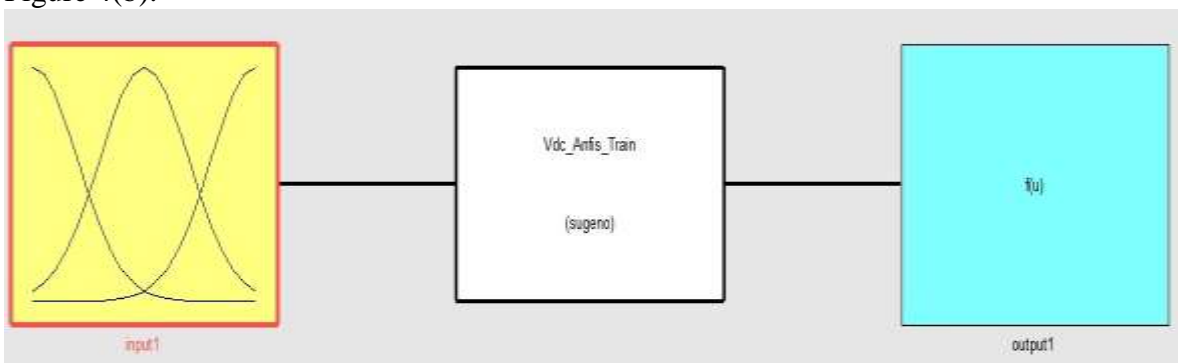

Fig. 4(a) FIS properties

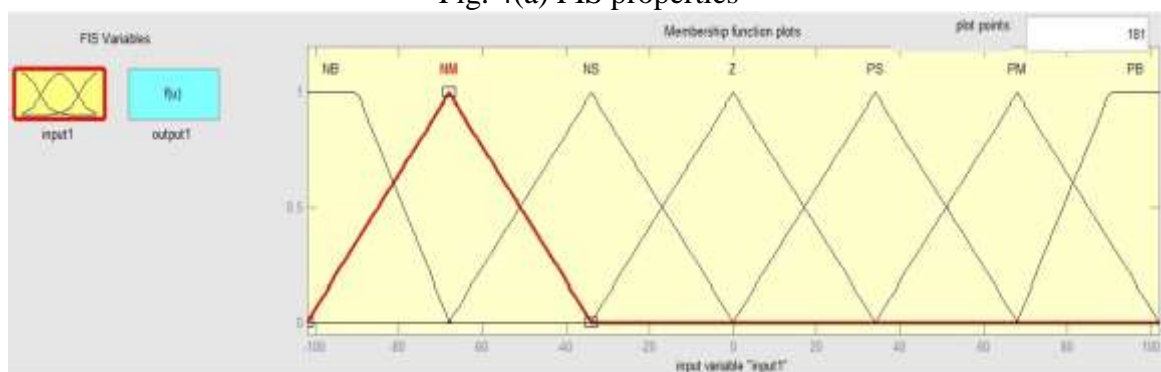

Fig. 4 (b) Membership function

Combining fuzzy logic and neural networks is a powerful tool in controlling, forecasting and modeling of composite systems such as photovoltaic systems. ANFIS constructs an input output mapping is based on both human knowledge and generated input output. The flow chart of the ANFIS system shown in Figure 5. In this process pair of input-

output data sets under different weather conditions is collected by simulation and trained by ANFIS controller.

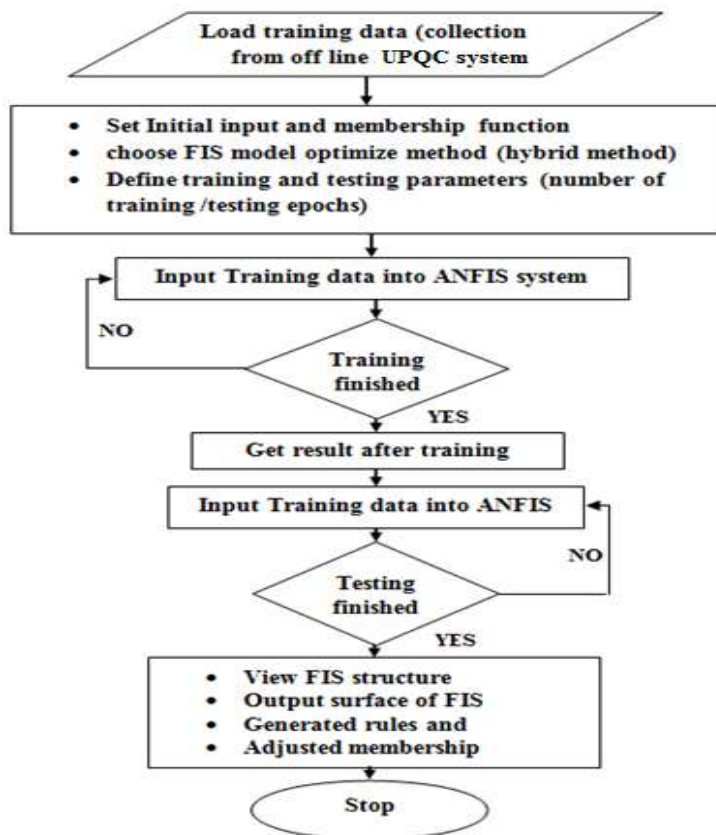

Figure 5 ANFIS system

ANFIS is one of the recent controllers used for regulate dc-link voltage for UPQC. In this paper ANFIS based UPQC is on produced to regulate dc link voltage. This technique is used for the compensating current to eliminate the harmonics and it can be generated by the system. The membership function can be optimized by using fuzzy logic implemented network neuron.

ANFIS can construct an input/output mapping and set up the data pairs based on both human knowledge (in the form of fuzzy IF- THEN rules) and simulation input output membership function and rules can be created using fuzzy logic. The various researches have been performed in the power quality maintenance. Some of the devices such as dynamic voltage restorer (DVR), uninterruptible power supplies (UPS) and many devices used for maintaining the quality power supply.

But, these devices are capable of maintaining the power quality in the distribution network .Hence this paper, a new technique a neuro fuzzy based on Takagi Sugeno fuzzy inference system is introduced. The generated fuzzy rules can be trained by using the neural network and we get a desired output of an UPQC FACTS device, designed for both compensate both source side and load side problems. The UPQC combines shunt active filter and series active filter t in a back to back connection, to reduce the power quality problems and power factor correction in a distribution network. Reactive can be performed. Hence this paper proposed Neuro fuzzy technique can be used to regulate DC link voltage of a

DSTATCOM and load waveforms can be maintained as constant. The DC link capacitor voltage maintained as constant level. The training data set for ANFIS by varying the working date. There is 2000 training data set and 500 epochs are used to train the ANFIS reference model. The training error condensed to approximately 0.09%, Figure 5 is shown in flow chart for execution of ANFIS based controller. The deliberate ANFIS organizer has also two inputs voltage V_s , and V_L dc capacitor link voltage V_{dc} , and one output duty cycle (D). The two inputs V_s , V_L and V_{DC} variables produce a control signal $D(t)$ which is execution to the inverter to adjust the duty cycle. The proposed controller is conscious to take advantage of simplicity and eliminate the slow converging, oscillation around the maximum voltage, and during transient period.

IV. Results and discussions

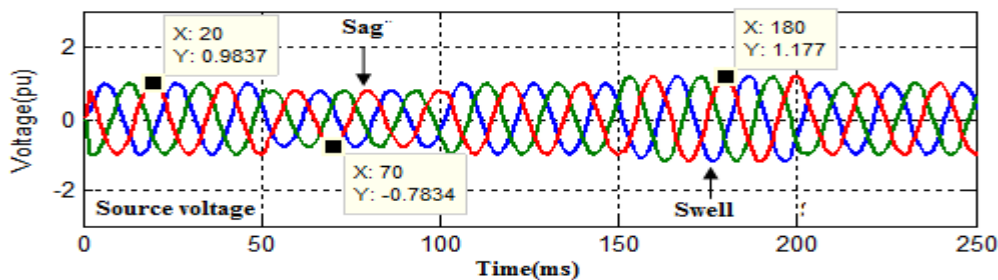

Figure 6 (a). Source voltage

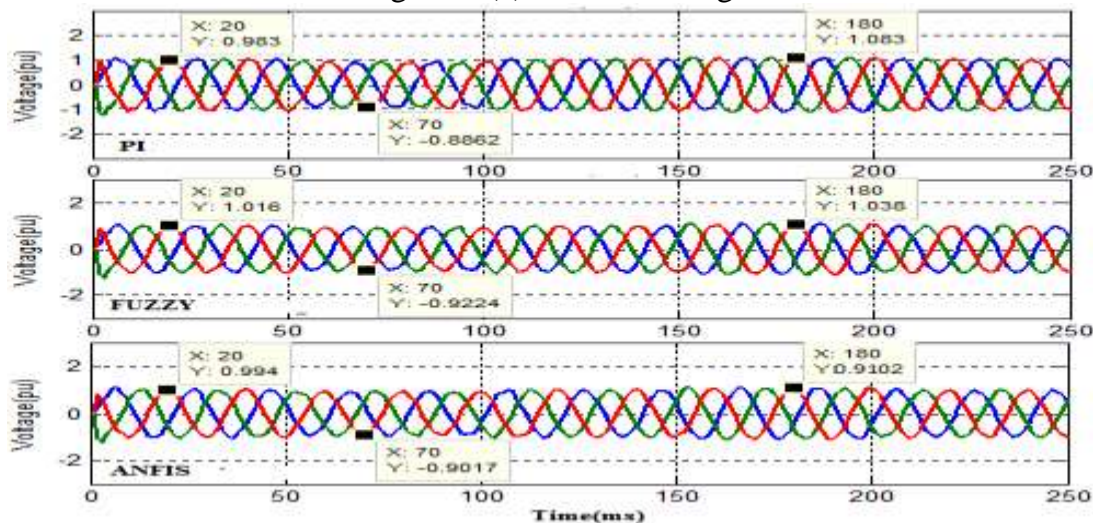

Figure 6 (b). Compensation of voltage sag and swell

The performance analysis of the ANFIS based controller for the UPQC can be appreciated by comparing the results of the multiple controllers. Performance analysis of PI, FLC and ANFIS controller are shown in Table 4.1. From the results, CNN controller THDs are maintain within permissible limits. The source voltage under distorted condition from 0.5 sec-0.1 sec undergoing sag condition. The source voltage with sag/swell before compensation has THDs of 2.66% in R phase. The load voltage with sag/swell after compensation has THDs 1.90 % in R phase respectively. An unbalanced created in load condition, the shunt compensator forces the load current to be sinusoidal in nature. The source current before compensation have THDs of 2.46 %. The source current after compensation have THDs of 1.21%. In the case of ANFIS controller the THD of load voltage

is 1.90% and load current THD is 1.82%. Hence in different controllers operation, from Table 5.2, it is clear that CNN controller gives better performance in terms of reduced THDs in voltage and current after compensation. The THD within the limit specified in the IEEE 519-1922

Table 4.1 Performance analysis of PI, FLC and ANFIS controller

Quantity/ R phase	PI controller		FLC		ANFIS Controller	
	THD %	Magnitude	THD %	Magnitude	THD %	Magnitude
Source Voltage	3.82	0.983	3.12	0.983	2.66	0.983
Load Voltage	2.52	0.983	2.23	1.01	1.90	0.994
Source Current	3.81	0.965	2.86	0.949	2.84	0.986
Load Current	2.53	0.968	1.92	0.965	1.82	0.978

4.1 Experimental results

The performance of proposed concept is validated through experimental results. Fig. 7 shows the hardware model. Fig. 8 and Fig. 9 shows the carrier wave generation and PWM wave form. The trained ANFIS controller is simulated using microcontroller unit. Due to the sudden variation of load creates the sag and swell conditions. Here single phase and three phase sag and swell wave forms are recorded using ANFIS controller. The experimental results during voltage sag condition is shown in Fig. 10 (a). The reduced source voltage is shown in Fig. 10 (a) (i). The compensated load voltage is shown in Fig. 10 (a) (ii). The experimental results during voltage swell condition is shown in Fig. 10(b). The increased source voltage is shown in Fig. 10 (b) (i). The compensated load voltage is shown in Fig. 10 (b) (ii). The experimental results of current compensation are shown in Fig. 11. It can be seen that supply current is non-sinusoidal. But the compensating load current is maintaining sinusoidal waveform.

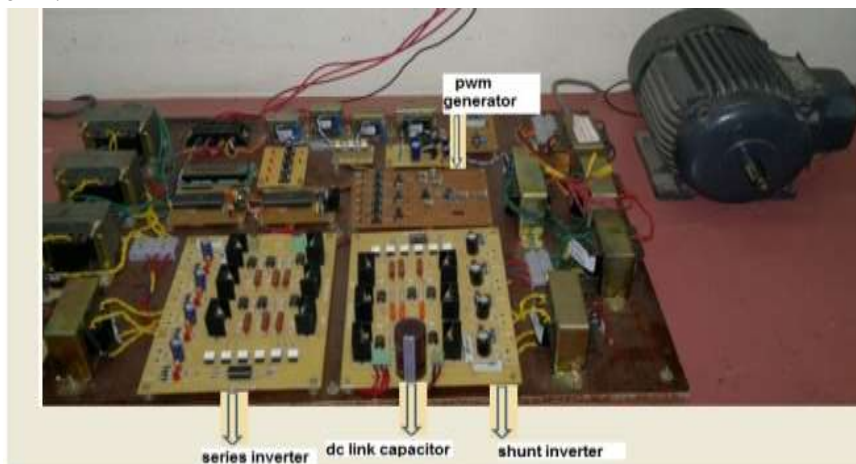

Fig. 7 Hardware model

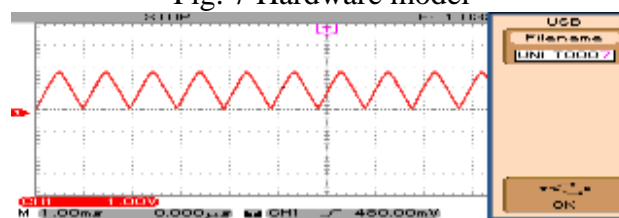

Fig. 8 Carrier wave generation

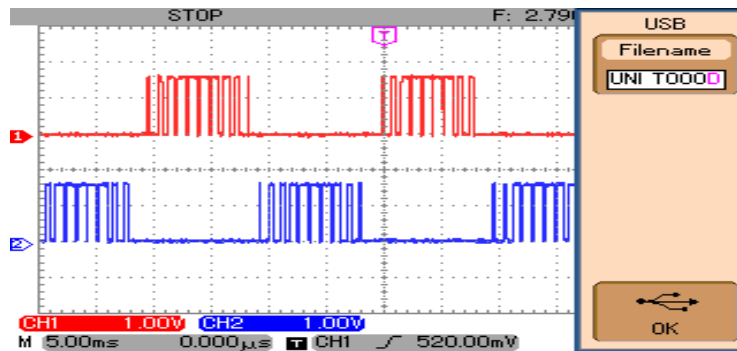
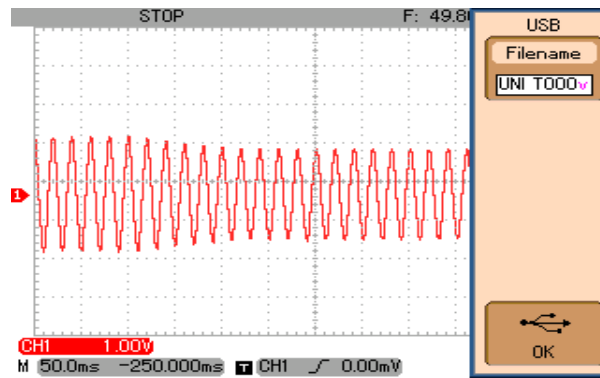
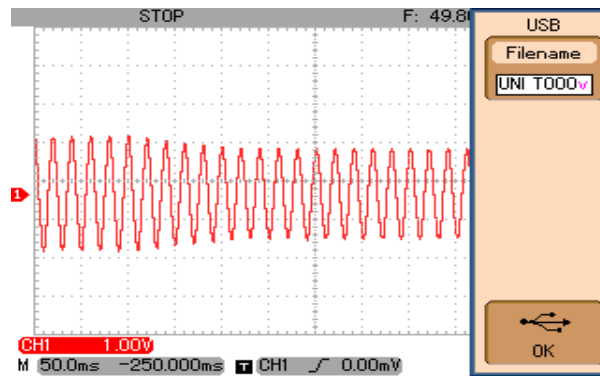

Fig. 9 PWM and Inverted PWM waveform



(i) Source voltage



(i) Source voltage

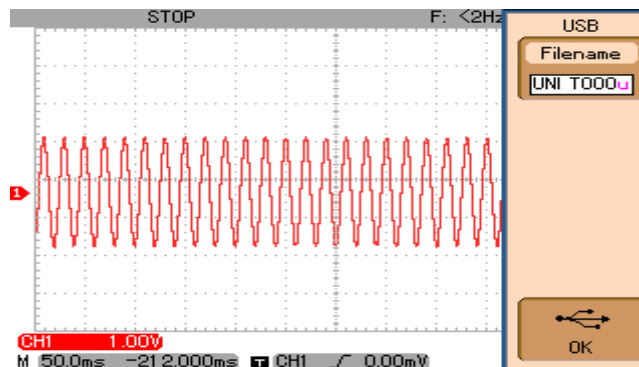

(ii) Load voltage

(a) Voltage sag condition

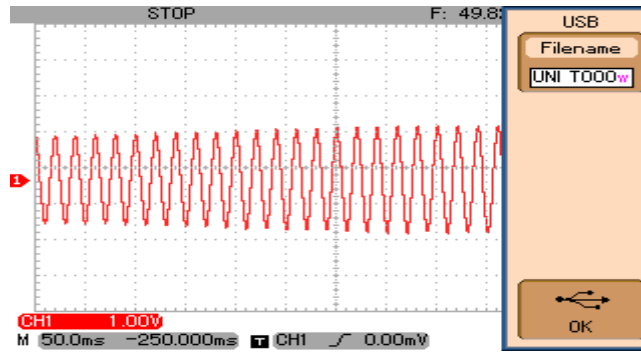

(i) Source voltage

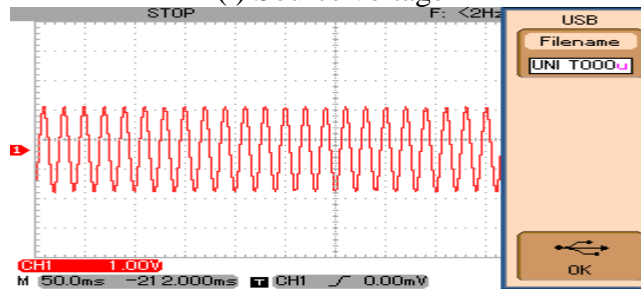

(ii) Load voltage

(b) Voltage swell condition

Fig. 10 Experimental results

(Single phase) voltage compensation

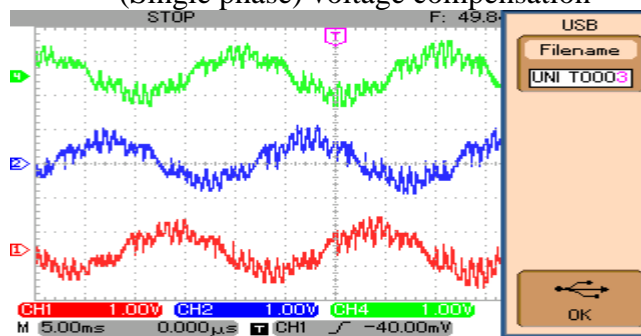

(i) Source current

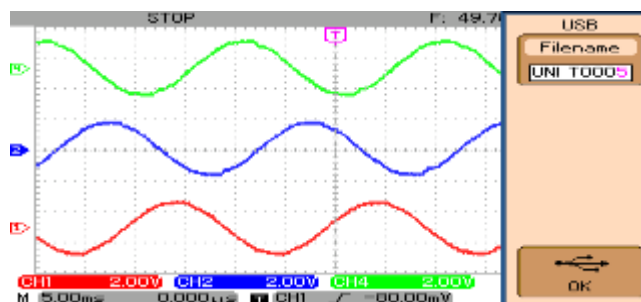

(ii) Load current

Fig. 11 Experimental results current compensation

V. Conclusions

The intelligent unified controller for the UPQC using ANFIS has been developed. The simulation model in the MATLAB/SIMULINK environment has been tested and the test results prove the efficiency of the novel method. The acceptable results for the proposed system summarized as follows. The control of voltage sag, swell, and reactive power is compensated. It is seen from the

simulation result that the THD for the output voltage of the proposed system is very low, compared with conventional controllers. The simulation results are validated experimentally using prototype.

References

- [1] Edris, Gyugyi, Rietman, Schauder, Torgerson and Williams, "The unified power flow controller: a new approach to power transmission control," IEEE Trans. on Power Delivery, ISSN: 0885-8993, Vol.10, no.2, pp.1085-1097, 1995.
- [2] Srinivas Bhaskar Karanki, Mahesh K. Mishra, "Particle Swarm Optimization-Based Feedback Controller for Unified Power-Quality Conditioner," IEEE Trans. on Power Delivery, ISSN: 0885-8993, Vol.25, no.4, pp.2814-2824, 2010.
- [3] Vadirajacharya G. Kinhal, Promod Agarwal, and Hari Oam Gupta, "Performance Investigation of Neural-Network-Based Unified Power-Quality Conditioner," IEEE Trans. on Power Delivery, ISSN: 0885-8993, Vol.26, no.1, pp.431-437, 2011.
- [4] Iurie Axente, Jayanti Navilgone Ganesh, Kevin Gaughan Malabika Basu, and Michael F Conlon, "A 12-kVA DSP-Controlled Laboratory Prototype UPQC Capable of Mitigating Unbalance in Source Voltage and Load Current," IEEE Trans. on Power Electronics, ISSN: 0885-8993, Vol.25, no.6, pp.1471-1479, 2010.
- [5] Vinod Khadkikar, and Ambrish Chandra, "UPQC-S: A Novel Concept of Simultaneous Voltage Sag/Swell and Load Reactive Power Compensations Utilizing Series Inverter of UPQC," IEEE Trans. on Power Electronics, ISSN: 0885-8993, Vol.26, no.9, pp.2414-2425, 2010.
- [6] H Fujita and H Akagi, "The unified power quality conditioner: The integration of series and shunt-active filters," IEEE Trans. On Power Electronics, ISSN: 0885-8993, Vol.13, no.2, pp.315-322, 1998.
- [7] Mehdi Forghani and Saeed Afsharnia, "On line Wavelet Transform-Based Control Strategy for UPQC Control System," IEEE Trans. on Power Delivery, ISSN: 0885-8977, Vol.22, 2007, pp.481-491, 2007.
- [8] Alfred Rufer, Du San Graovac, and Ladimir A Katic: Power Quality Problems Compensation With Universal Power Quality Conditioning System," IEEE Trans. on Power Delivery, ISSN: 0885-8977, Vol.22, no.2 pp.968-975, 2007.
- [9] Millnitz dos Santos, RJ, Da Cunha, JC & Mezaroba, M, 2014, 'A simplified control technique for a dual unified power quality conditioner', IEEE Transactions on Industrial Electronics, Vol. 61, no. 11, pp. 5851-5860
- [10] Sanjib ganguly 2014, 'Unified power quality conditioner allocation for reactive power compensation of radial distribution networks', IET Generation Transmission and Distribution, Vol.8, no.8, pp.1418-1429.