

# Selective Harmonic Elimination (SHE) for 3-Phase Voltage Source Inverter (VSI)

**V.Karthikeyan,**

SVS College of Engineering, Coimbatore, India  
[karthick77keyan@gmail.com](mailto:karthick77keyan@gmail.com)

**V.J.Vijayalakshmi,**

Sri Krishna College of Engg & Tech., Coimbatore, India  
[vjjik810@gmail.com](mailto:vjjik810@gmail.com)

**P.Jeyakumar**

Karpagam University, Coimbatore, India  
[Jeyak522@gmail.com](mailto:Jeyak522@gmail.com)

**Abstract:** *The simple Selective Harmonic Elimination (SHE) for 3-Phase Voltage Source Inverter (VSI) is presented here. The proposed work is to examine the Selective Harmonic Elimination (SHE) and to eliminate harmonics produced by Pulse Width Modulation (PWM) inverter. The selective harmonic elimination method for three phase Voltage Source Inverter (VSI) is generally based on ideas of opposite harmonic injection. In this proposed scheme, the lower order harmonics (3rd, 5th, 7th, and 9th) are eliminated by the dominant harmonics of same order generated in opposite phase by Sinusoidal Pulse Width Modulation (SPWM) inverter, The elimination of precise low-order harmonics from a given voltage/current waveform is accomplished by Selective Harmonic Elimination (SHE) technique and by using this scheme the Total Harmonic Distortion (THD) created has been reduced which is more effective. Analysis of Sinusoidal Pulse Width Modulation (SPWM) technique and Selective Harmonic Elimination (SHE) is simulated using MATLAB/SIMULINK model.*

**Key words:** *Selective Harmonic Elimination (SHE), Pulse Width Modulation (PWM), Total Harmonic Distortion (THD), and Voltage Source Inverter (VSI)*

## 1. Introduction

DC-AC converters are power electronic circuits frequently named as an inverter. Inverter is classified into two types. Voltage source inverter is a one category of inverter. And it has the lead of uncomplicated execution and less cost. In such an inverter, the output voltage is able to augmented or decreased as of the input voltage level by adjusting the duty ratio of its switch. The inverter paraphrase can be achieved moreover by proscribed turn-on and turn-off devices (e.g. BJTs, MOSFETs, IGBTs, and GTOs) or by forced commutated thyristors, depending on their applications. The DC power input to the inverter may be battery, fuel cell and solar cell. But, in most of the industrial applications, the inputs are provided to the rectifier circuits.

Rectifier is a process of conversion of AC-DC. Sinusoidal pulse width modulation (PWM) technique [3, 4] has the advantage of easy implementation.

The Fig. 1. Shows the block diagram of Selective Harmonic Elimination (SHE) technique [2] for three phase Voltage Source Inverter (VSI). In this paper DC voltage (500V) is used as source of an inverter. Selective Harmonic Elimination (SHE) method is used to reduce the quantity of Total Harmonic Distortion (THD) in the existing system. Three phase voltage source inverter converts the DC into AC which in this is fed to the load (RL). Sinusoidal Pulse Width Modulation (PWM) technique is compared with triangular waveform to produces the pulse wave forms; the achieved results are then given to the switches with the desired frequency. Selective Harmonic Elimination (SHE) technique is generally based on the ideas of opposite harmonic injection (3rd, 5th, 7th and 9th order) and it's given to three phase voltage source inverter switches. The fig 1 shows the block diagram of complete Selective Harmonic Elimination (SHE) technique.

## 2. Voltage Source Inverter

The schematic diagram for a basic three phase Voltage Source Inverter (VSI) is shown in Fig. 2. A Three phase voltage source inverter circuit [5] changes DC input voltage to a three phase variable frequency, variable voltage output. Performance of voltage source multilevel inverter-fed induction motor drive is illustrated for more level of inverter is used. The input DC voltage can be from a DC source or rectified AC voltage. A Three phase inverter can be constructed by combining three single phase half bridge inverters. It consists of six power switches with six associated with freewheeling diodes. The switches are opened and closed periodically in the

proper sequence to produce the desired output waveform. Basically, there are two possible schemes of gating the devices.

- Each switch conducts for  $180^\circ$
- Each switch conducts for  $120^\circ$

But in both these schemes, gating signals are applied and removed at  $60^\circ$  intervals of the output voltage waveform.

### 3. Selective Harmonic Elimination Technique

Selective harmonic elimination control has been a widely researched alternative to traditional pulse-width modulation technique. The elimination of specific low-order harmonics from a given voltage/current waveform achieved by Selective Harmonic Elimination (SHE) technique. Determination of pulse pattern for the elimination of lower order harmonics of a PWM inverter necessitates solving a system of nonlinear transcendental equations.

Here the low order harmonics are eliminated by the dominant harmonic generated wave form. A method to eliminate the most significant harmonic components of line voltage waveforms of the inverter by SHE is also formulated. [2, 11]. In this method there is no need to calculate the firing angles for placing notches. Here, the lower order harmonics will be reduced by the dominant harmonics of same order generated in opposite phase by sine PWM inverter. This is achieved by varying the phase angle of the carrier wave of the sinusoidal Pulse Width Modulation (PWM) inverter;

Determination of pulse pattern for the elimination of lower order harmonics of a PWM inverter necessitates solving a system of nonlinear transcendental equations [5, 12] which generates the dominant harmonics with sidebands very close to the amplitude of prominent voltage harmonics present in the system but in opposite polarity. Selected solutions for the switching angles for harmonic eliminations are presented & switching angles for elimination desired harmonics from different order is illustrated. In On-line computation of switching angle ( $\alpha$ ) is just evaluation of polynomial equation by substituting value of modulation index ( $m$ ) [7, 8 and 9] In this method first, calculate the Total Harmonic Distortion (THD) for 3rd, 5th, 7th and 9th order harmonics. Then calculate the amplitude of these order (3rd, 5th, 7th, and 9th) harmonics with help of Total Harmonic Distortion (THD).

After calculating amplitude, injecting the same order of harmonics in opposite amplitude Thus the resultant disorder sine wave is compared with

triangular waveform and results in pulse are produced and will give to the switches. This method is simple and easy implementation method for reducing the Total Harmonic Distortion (THD). The simulation of three phase voltage source inverter by using selective harmonic elimination method is done in MATLAB/SIMULINK software and shown in Fig. 3.

Generally In inductor filter; the ripple feature is unswervingly comparative to the load resistance (RL). On the other hand in a capacitor filter, it is unreliable inversely through the load. Thus if we unite the inductor filter with the capacitor the ripple aspect will turn out to be more or less autonomous of the load filter. It is also said to be as LC-section. In LC filter an Inductor is connected in series with the load (RL). It offers high resistance path to the AC mechanism and allows DC component to flow through the load (RL). The capacitor transverse the load associated parallel and filter out if any AC constituent flowing through the inductance, In this manner the AC component are filtered and a flat DC is supplied all the way through the load. Here the distorted harmonics are removed and the smooth wave forms are obtained

### 4. Output Results and Discussions

The output results play a vital role in the projected work. Here the generation of lower order harmonics, Dominant harmonics, Phase angle output wave forms, and Line voltage output wave forms are obtained by the Matlab /Simulink model. Fast Fourier Transform analysis are also obtained. Fig.4 represent the phase voltage output waveform where the amplitude and time in period represented in obtaining the opposite phase to eliminate the harmonics generated.

Fig.5 illustrates the line voltage output wave form, injecting the same order of harmonics in opposite amplitude Thus the resultant disorder sine wave is compared with triangular waveform and results in pulses are produced. Fig.6 represents the output wave form for Selective Harmonic Elimination(SHE) with LC-section, this shows RGB Harmonics of amplitude in Voltage vs. Output Current in Time(ms). Fig.7 shows the FFT analysis of Selective Harmonic Elimination (SHE) with fundamental frequency of 50 Hz we got 113.3 and the Total Harmonic Distortion of 70.06% this is obtained by without using the LC filter.

Fig.8 FFT analysis of Selective Harmonic Elimination (SHE) with fundamental frequency of 50 Hz we got 113.3 but the Total Harmonic

Distortion is reduced up to 1.47% this results is produced by using the LC filter. The result what we got is more effective than the conventional methods the dominant harmonics of the same order of the sine wave is more efficient Thus the result shows that the Selective Harmonic Elimination (SHE) technique is improved by reducing the Total Harmonic Distortion (THD) up to 1.47%.

## 5. Comparison of Results

Table .1 shows the comparison between the sinusoidal Pulse Width Modulation (PWM) method for three phase voltage source inverter and Selective harmonic elimination for three phase voltage source inverter. From the comparison it is evident that Selective Harmonic Elimination (SHE) method is better than sinusoidal Pulse Width Modulation (PWM) technique. Figure 8 represents the FFT analysis for Selective Harmonic Elimination (SHE) with filter. Here LC filter is used.

Table. 1.

Comparison of results

S.No	Harmonic Elimination Techniques	FFT Analysis of Magnitude (% of fundamental)	Total Harmonic Distortion (THD)
1	Sinusoidal PWM Technique	113.3	70.06
2	Selective Harmonic Elimination Technique	111.7	1.47

## 7. Conclusion

The paper presents a selective harmonic elimination technique for three phase voltage source inverter with the RL load. A Three phase Voltage Source Inverter (VSI) changes DC input voltage to a three phase variable frequency variable voltage output. The elimination of specific low-order harmonics from a given voltage/current waveform achieved by Selective Harmonic Elimination (SHE) technique. We unite the inductor filter with the capacitor the ripple aspect will turn out to be more or less autonomous of the load filter. Finally Analysis and comparison of Total Harmonic Distortion (THD) for

sinusoidal Pulse Width Modulation (PWM) technique and selective harmonic elimination technique has been done. From the comparison it is very apparent that the Total Harmonic Distortion (THD) for selective harmonic technique is less than that of sinusoidal Pulse Width Modulation (PWM) method. The anticipated work has been examined the Selective Harmonic Elimination (SHE) method to eliminate low order harmonics produced by Pulse Width Modulation (PWM) inverter.

## References

- [1] Ray, Chatterjee, R.N. and Goswami, S.K: *Reduction of voltage harmonic using optimization – based combined approach on IET Power Electronics*, 2008
- [2] Mohamed S.A.Dahidah and Vassilios G. Agelidis: *Selective harmonic elimination PWM control for Cascaded multilevel voltage source converters: A generalized formula IEEE Transaction on power electronics*, 2008
- [3] Wells, Jason R. Xin Geng, Chapman, Patrick L. and Krein, Philip T.: *Modulation based harmonic elimination, IEEE Transactions on Power Electronics*, 2007.
- [4] Fellow, Javier Napoles, Jose Ignacio Leon, and Aguirre, Miguel A.: *A flexible selective harmonic mitigation to meet grid codes in three level PWM converters, IEEE Transactions on Industrial Electronics*, 2007.
- [5] Hadji, S. Touhami O. and C.J.Goodman. : *Vector-optimized harmonic elimination for single- phase pulse width modulation inverters/converters IET Electr.Power Appl.*, 2007
- [6] Aglidis V.G., Balouktsis A., and Cosar C.: *Multiple sets of solutions for harmonic elimination PWM bipolar waveforms: analysis and experimental verification” IEEE Trans.Power Electron.* 2007.
- [7]. Fanghua Zhang and Yangguang Yan: *Selective Harmonic Elimination PWM Control Scheme on a Three-Phase Four-Leg Voltage Source Inverter, IEEE Transactions on Power Electronics.*2009
- [8]. Hassan Feshki Farahani: *Modulation Index Effect on the 5-Level SHE-PWM Voltage Source Inverter Engineering*, 2011
- [9]. N. G. Apte, r. V. N. Bapat,, V. S. Jagdale and N. I. Dhang: *On-Line Control of 1ph. She-Pwm Voltage Source Inverter for Statcom Applications*, 2010
- [10]. Jovitha Jerome and V. Jegathesan: *Elimination of lower order harmonics in Voltage Source Inverter feeding an induction motor drive using Evolutionary Algorithms*, Expert Systems with Applications.2011
- [11]. Nisha G. K., Member, IAENG, Ushakumari S. and Lakapampil Z. V. *Harmonic Elimination of Space Vector Modulated Three Phase Inverter*, 2011
- [12]. Neela shetty Kashappa and Ramesh Reddy: *Performance of Voltage Source Multilevel Inverter – Fed Induction Motor Drive Using Simulink* 2011

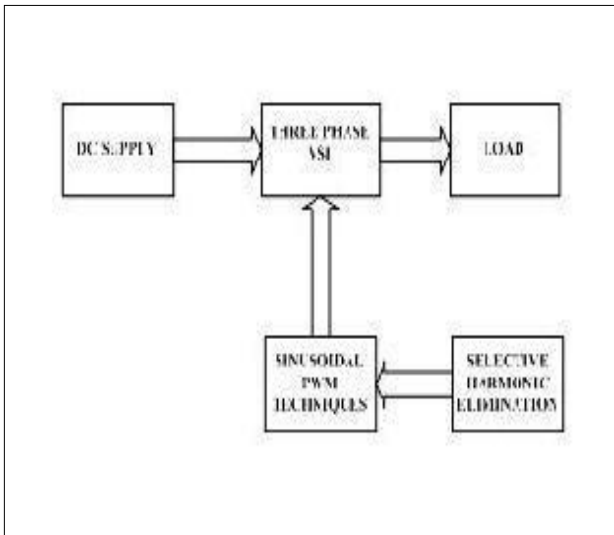

Fig. 1. Complete block diagram of proposed Method

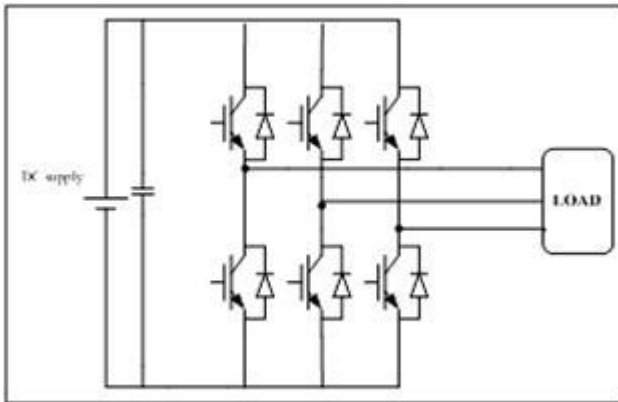

Fig. 2. Circuit diagram for three phase Voltage Source Inverter

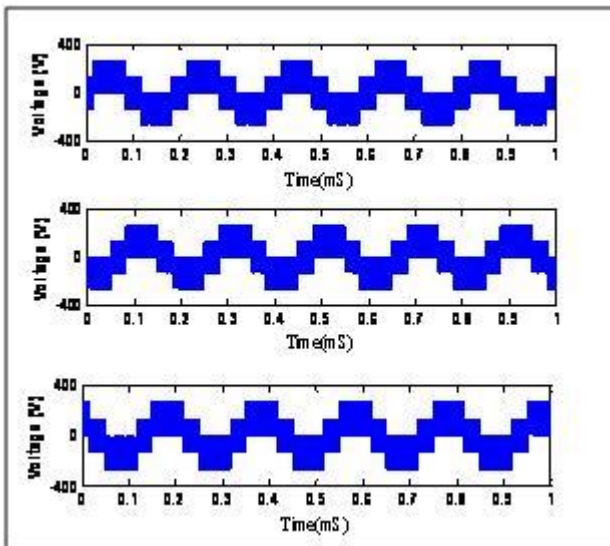

Fig. 4. Phase voltage output waveform

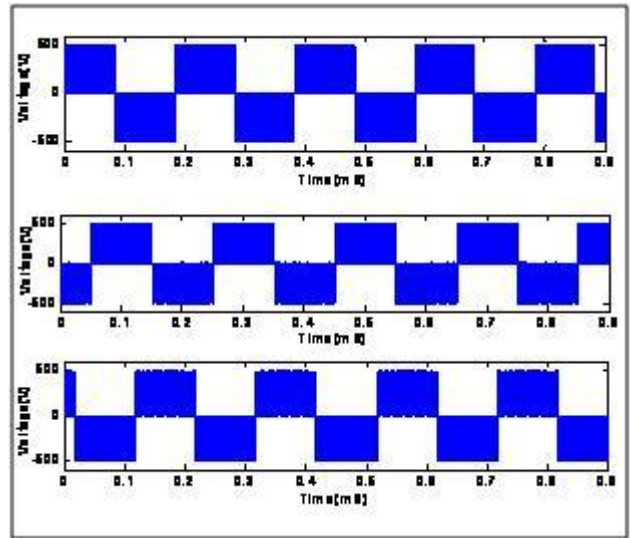

Fig. 5. Line voltage output waveform

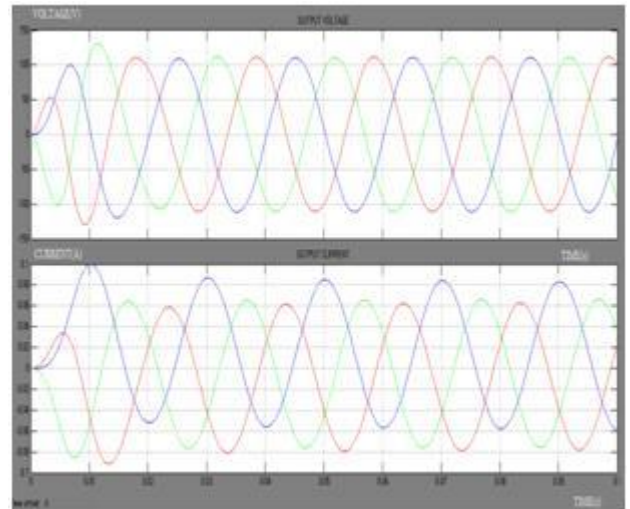

Fig. 6. Output waveform for Selective Harmonic Elimination (SHE) with filter

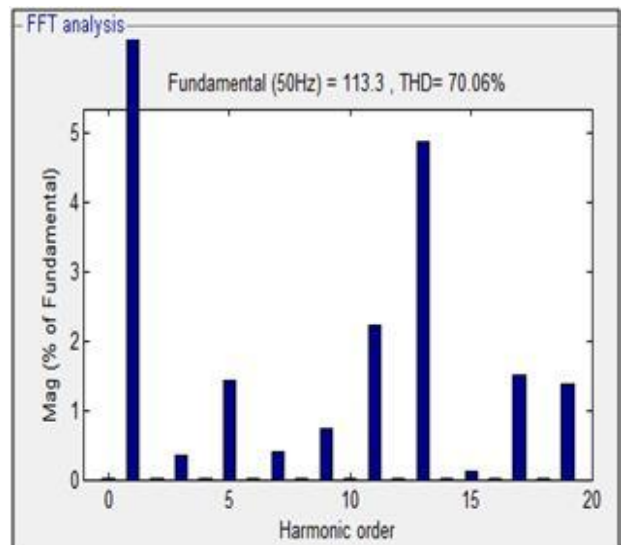

Fig. 7. FFT analysis for Sinusoidal PWM Technique

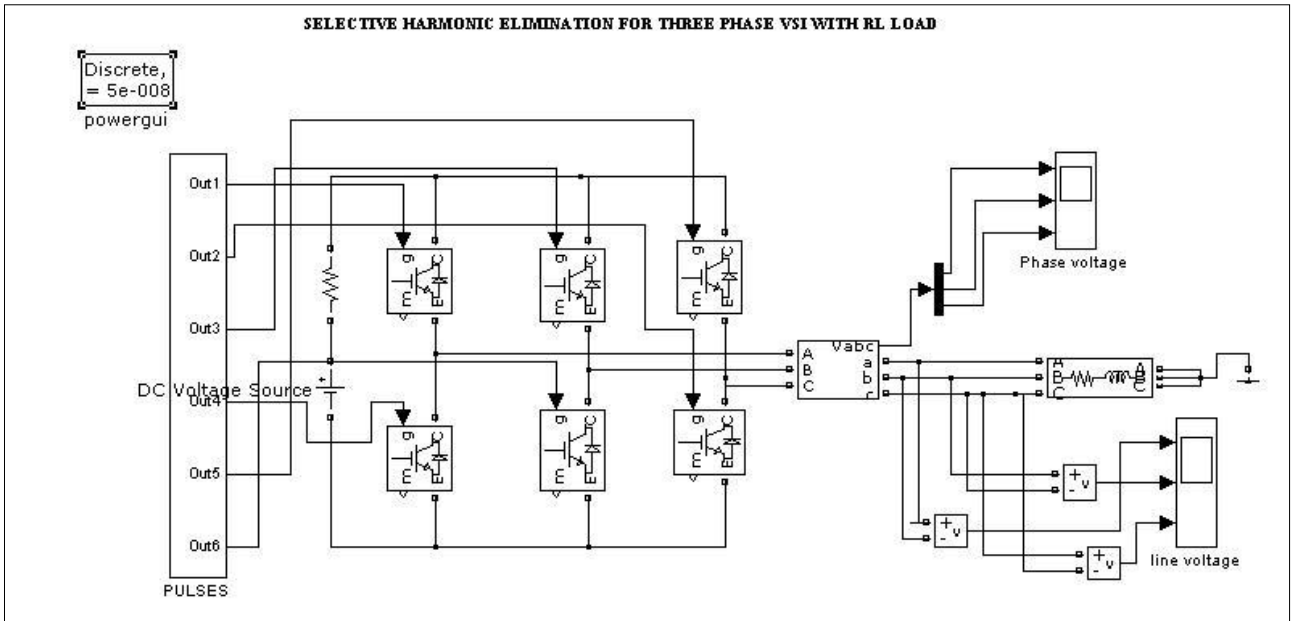

Fig. 3. Selective Harmonic Elimination for three phase voltage source inverter with RL load

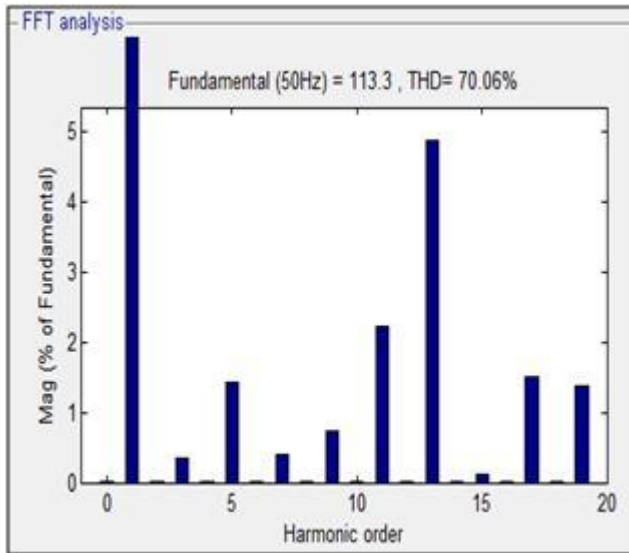

Fig. 8. FFT analysis for Selective Harmonic Elimination (SHE)