

Resonant dc- dc converter for Datacenter and super computer applications

N.Soundiraraj, K.Palanivelrajan I.Sayed Mohammed and Dr.K.Aruljeyaraj

Assistant professors, Department of electronics and communication engineering,
PSNA College of engineering and technology, Dindigul, Tamilnadu,
Email:soundar06@gmail.com

Abstract: In this article proposes the parallel operation of converters for load sharing in datacenters. A new control approach is proposed for switch controlled capacitor LLC converter. The output voltage regulation is achieved by the switching frequency control. It can give the good frequency variation range and peak gain range compared to conventional converters. To attain load sharing the half wave switch controlled capacitor(SCC) is used to control the resonant frequency of each LLC stage. The simulation results are compared with experimental results. A 600w prototype model is developed to prove the feasibility.

Key words: resonant converter, frequency control, soft switching, power grid, super computer, data center.

1. Introduction

In this article proposes the switch controlled capacitor (SCC)-LLC converter. The resonant frequency is controlled by using switch controlled capacitor. Because of this, the regulation of output voltage is attained in constant switching frequency control. This gives good solution for phase shedding of each converter, load sharing of converters by the parallel operation, and interleaving operation of converters. But some limitations there in fixed switching frequency operation of resonant converters; they are variation range in load current and input voltage compared with the traditional converters in switching frequency control. The new control strategy for switch controlled capacitor (SCC) resonant converter is focused in this chapter. This control method has achieved the interleaving operation of converters at the same time holds the benefits of variable switching frequency control. This article discusses about the following points.(i).compares the modulation between switching frequency and resonant frequency. (ii).proposes the new control technique and analysis and design of that control technique.(iii).compares the practical results with theoretical and simulation results.(iv).summary.

2. Comparison between the Modulations of Switching Frequency with Resonant Frequency

The various literatures discuss about the constant switching frequency operated resonant converter. That technique is used to solve the load sharing problem and interleaving operation. Therefore that control technique is used in high

current applications with higher efficiency. The constant switching frequency LLC converters present the different characteristics from traditional converters due to it uses resonant frequency modulation in it is place of switching frequency modulation. The comparison between the modulations of switching frequency with resonant frequency is as follows. The equation (1) shows the voltage gain of proposed converter derived from The Fundamental Harmonic Approximation (FHA) model.

$$M = \frac{K}{\sqrt{\left[\left(\frac{\omega_r}{\omega_s}\right)^2 - K - 1\right]^2 + \frac{\pi^4 \omega^2 L_p^2}{64N^4 R_L^2} \left[\left(\frac{\omega_r}{\omega_s}\right)^2 - 1\right]^2}} \quad (1)$$

$$M = \frac{NV_0}{V_{in}}, \quad (2)$$

$$N = \frac{N_p}{N_z}, \quad (3)$$

$$K = \frac{L_p}{L_z}, \quad (4)$$

$$\omega_s = 2\pi f_s, \quad (5)$$

$$\omega_r = \frac{1}{\sqrt{L_r C_r}} \quad (6)$$

Where

ω_r = The resonant frequency in radians.

ω_s = The switching frequency in radians

R_L = The Load resistance

K = The load resistance

L_p = The parallel inductance

N = The transformer turns ratio

M = Resonant tank gain

The efficiency curves resulted from resonant frequency modulation (FrM) and switching modulation (FsM) are drawn using the equation (1) with set of values of N , R_L , K , L_p , respectively as depicted in the figure .1.

The resonant frequency modulation (FrM) curve obtained when the switching frequency (ω_s) is fixed and resonant frequency (ω_r) is varied. The normalized frequency in resonant frequency modulation is defined as the ratio between the resonant frequency to the switching frequency (ω_r/ω_s).The switching frequency modulation (FsM) curve drawn when resonant frequency (ω_r)

is constant and the switching frequency (ω_s) is varied.

The figure 1 shows the Normalized frequency versus gain of resonant frequency and switching frequency modulations. The switching frequency modulation gives higher efficiency compared with the resonant frequency modulation.

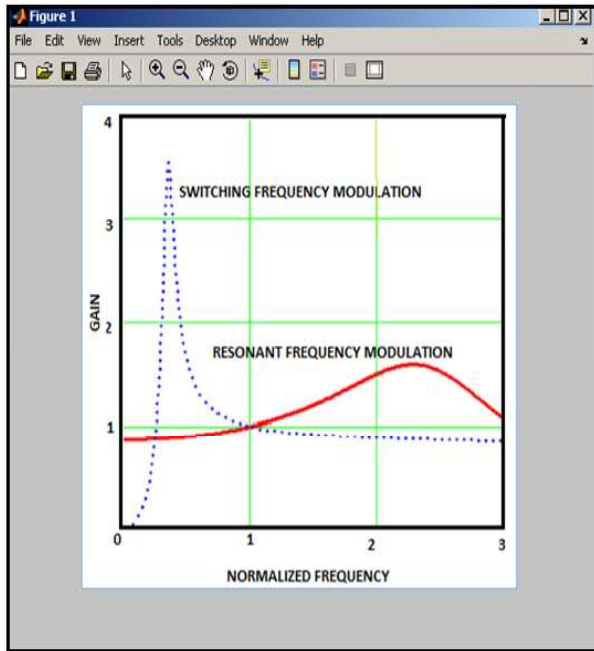

Figure. 1 Gain versus normalized frequency with resonant frequency and switching frequency modulations

Resonant frequency modulation has less effective in impedance point of view compared to the switching frequency modulation. Two MOSFET'S with gate driver circuits are used to control the SCC, which increases the conduction loss and complicated circuit. Therefore a half wave SCC can be utilized, this is more attractive. The next section discuss about the half wave SCC.

3. Switching Frequency Controlled LLC Converters

3.3.1. SCC – LLC Converter with switching frequency control

The interleaving operation of SCC-LLC converters are connected in parallel, the switch frequency of all phases must be same. And at the same time the switching frequency modulation has more helpful than resonant frequency modulation. So the proposed the innovative control technique is in the subsequent paragraphs.

(i).All SCC-LLC converter phase output voltage controlled by the switching frequency and all SCC-LLC phases operates same switching frequency but its variable based on the output voltage requirements.

(ii).The output current ripple cancellation is done, by applying interleaved gate driving pulse to each phase of SCC-LLC converters.

(iii).The load current sharing is obtained by SCC control method, because of the component tolerance The figure 2 shows the improved topology. This new topology is suitable for interleaving operation of SCC-LLC converters. The figure 3 shows voltage and current range of the proposed converter.

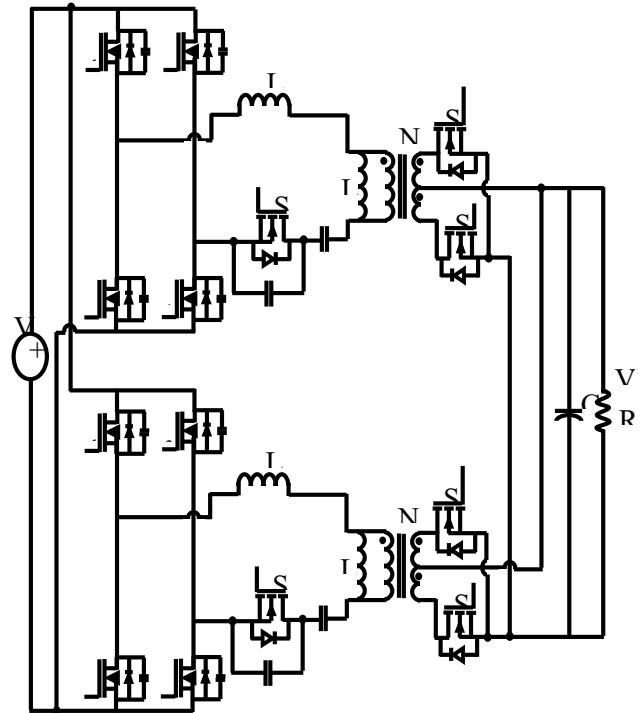

Figure 2. Parallel operation of resonant converters

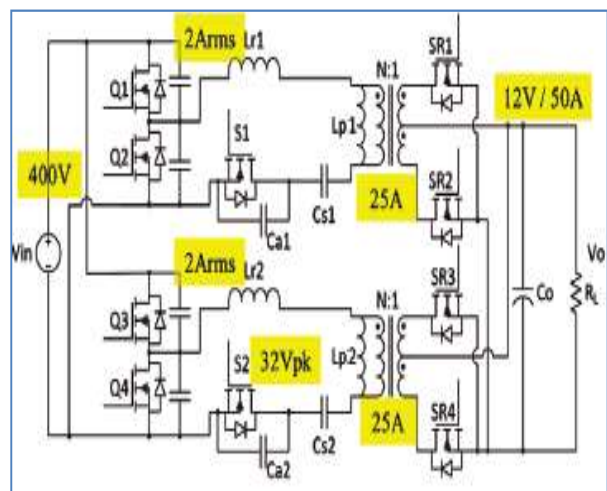

Figure 3. Two converter circuits with current and voltage range.

3.3.2. Comparison between half wave and full wave switch controlled capacitor (SCC)

The half wave switch controlled capacitor operating waveform are shown in the figure.4. Here the control angle (α) is varied from 0 to π and there is only one MOSFET, but the control method is same as in the full wave switch controlled capacitor.

The switch controlled capacitor MOSFET is turn on when the Capacitor (C_a) voltage discharging and reaches to zero for diminish the power loss of MOSFET's body diode. The C_a voltage is fully discharging and reaches to zero, then immediately the SCC MOSFET is ON.

The MOSFET acts like a synchronous rectifier from the capacitor (C_a) voltage zero crossing point to the resonant current zero crossing point. This is not affecting the modulation of equivalent capacitance.

The expression (7) shows the equivalent capacitance value of half wave SCC, and that expression is derived based on fundamental harmonic estimation method.

$$C_{SC,HW} = \frac{2C_a}{2 - (2\alpha - \sin 2\alpha) / \pi} \quad (7)$$

The two extreme conditions to design the SCC equivalent capacitance are,

- (i). SCC switches always ON,
- (ii). SCC switches always OFF.

The equivalent capacitance value is large when the SCC switches ON. And the equivalent capacitance value is equal to (C_a) when the SCC switches OFF. Hence other conditions do not affect the overall design accuracy.

5. Experimental Results

The practicability and the reward of the planned control strategy are verified using practical model of a 600Watts two phase interleaved variable switching frequency half wave switch controlled capacitor converter. The specification details are listed in the table 1.

Table 1

Specification details of experimental model

SR MOSFET	BSC011N03LS
Switch controlled capacitor MOSFET	BSC060N10NS3G
Full bridge MOSFET	IPB60R190C6
Turns ratio of transformer	18:1, Centre tapped
Output power	550Watts, (225Watts per phase)
Output voltage	12V
Input voltage	430V Maximum/330V Minimum

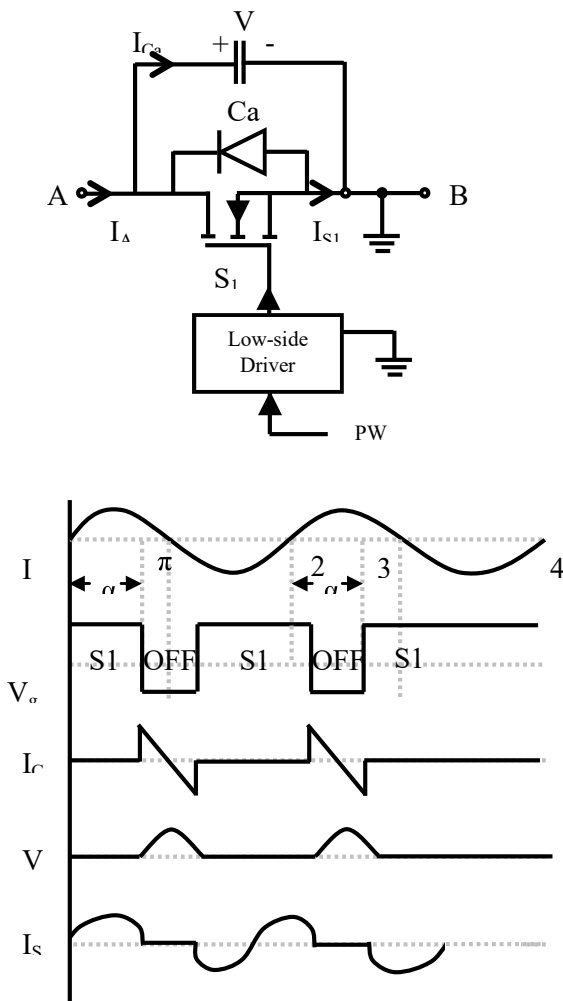

Figure.4 Half wave SCC, Operating wave forms.

For test the load sharing performance of the converter, resonant inductors are implemented with leakage inductance of the transformers, and are purposely made not equal.

The digital controller is implemented using a microchip DSC dsPIC33FJ32GS606. Load current (A) versus efficiency (η %) with phase shedding and without phase shedding of LLC converter are shown in the fig.5. The 26A (50%) load efficiency is improved from 95% to above 95.5%, and the 5A (10%) load efficiency is improved from 82% to 90%. When the load current is below 49%, one phase is shut down

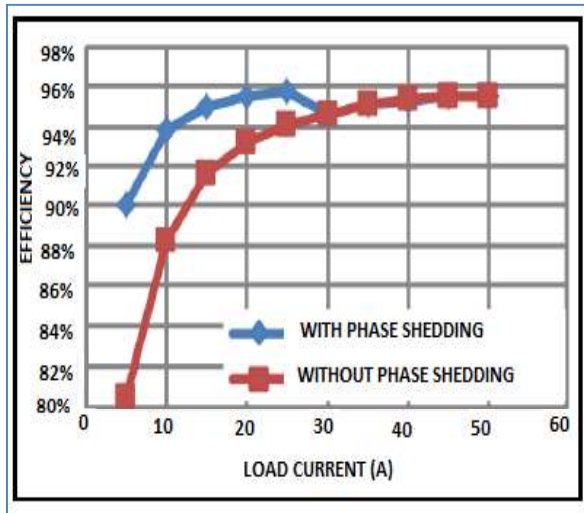

Figure.5 Load current (A) versus efficiency (%) with phase shedding and without phase shedding of LLC converter.

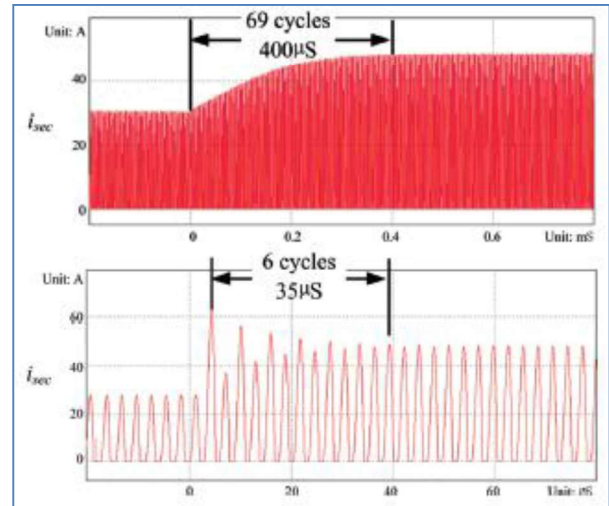

Figure.8. Performance of the proposed converter with sudden change in the output load corresponding to different controllers.

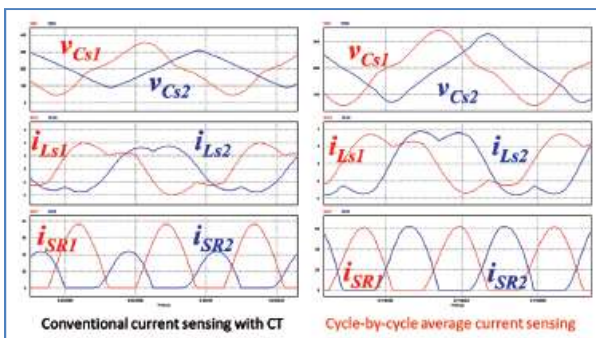

Figure.6. The Load sharing performance of conventional and proposed converters.

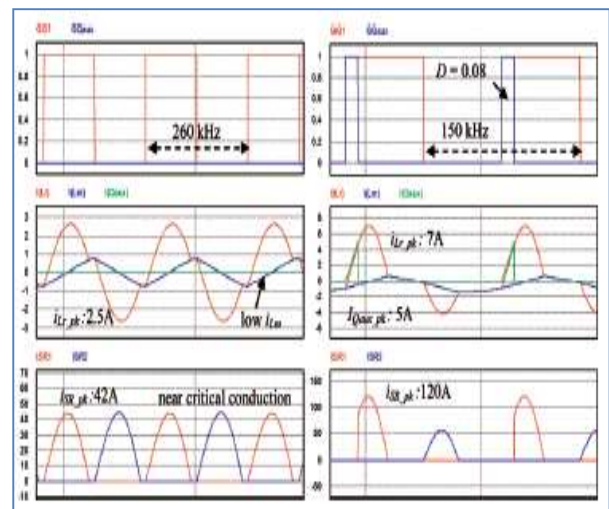

Figure.9. Converter operation with different loads.

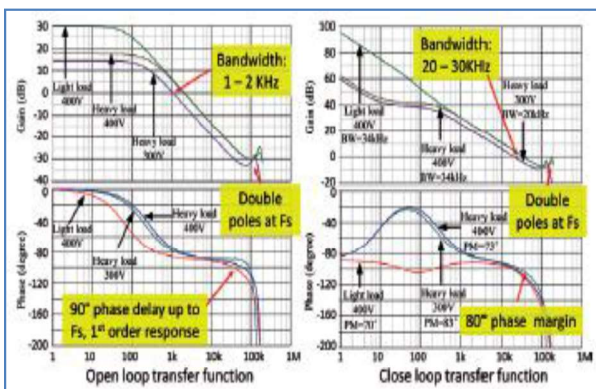

Figure.7. Bode plot of proposed converter with open loop and closed loop control performance.

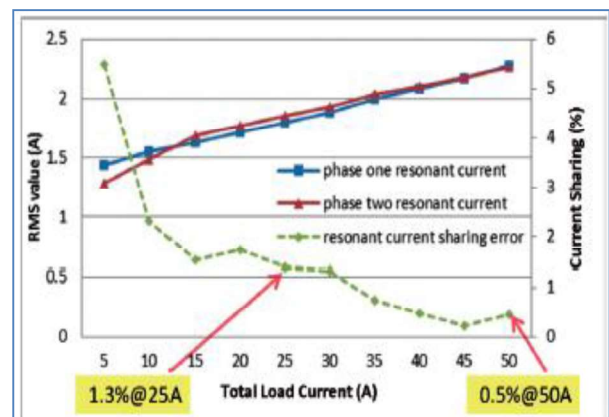

Figure.10. load sharing error of converters.

Figure.6.shows the Load sharing performance of conventional and proposed converters. And also the figure 7 to 10 shows various results of the proposed converter.

6. Conclusion

A innovative control approach is proposed for switch controlled capacitor LLC converter. The output voltage regulation is achieved by the switching frequency control. The switch controlled capacitor LLC converter load sharing characteristics are studied. To determine the optimal switch controlled capacitor value a visual assist design technique is proposed. A two phase interleaved switch controlled capacitor LLC converter with power rating of 600 watts prototype is developed. It shows the efficiency improvement in light load, cancellation of current ripples, and good load sharing performance. From the various results, concluded that the proposed LLC converter is suitable for super computers and datacenter applications.

REFERENCES

1. Z. Lu, Y. Gu, L. Hang, Z. Qian, and G. Huang, "LLC Three-level series resonant DC/DC converter," IEEE Trans. Power Electron., vol. 20, no. 4, pp. 781–789, Jul. 2005.
2. C. Cecati, C. Buccella, and H. Latafat, "Surveyy - Digital control of power converters" IEEE Trans. Ind. Inform., vol. 8, no. 3, pp. 437–447, Aug. 2012.
3. D. Czarkowski, and M. K. Kazimierczuk Resonant Power Converters, 2nd ed. Hoboken, NJ, USA: Wiley-Interscience, 2011.
4. S. Wang, and M. K. Kazimierczuk, "series resonant converter for continuous conduction mode-Frequency domain analysis," IEEE Trans. Power Electron., vol. 7, no. 2, pp. 270–279, Apr. 1992.
5. A. K. Upadhyay, Y. G. Kang, and D. L. Stephens, "Analysis and design of a half-bridge parallel resonant converter operating above resonance," IEEE Trans. Ind. Appl., vol. 27, no. 2, pp. 386–395, Mar./Apr. 1991.
6. J. L. Sosa, M. Castilla, J. Miret, L. G. de Vicuna, and J. Matas, "Modeling and performance analysis of the DC/DC series parallel resonant converter operating with discrete self-sustained phase-shift modulation technique," IEEE Trans. Ind. Electron., vol. 56, no. 3, pp. 697–705, Mar. 2009.
7. X. Li, "A LLC-Type dual-bridge resonant converter: Analysis, design, simulation, and experimental results," IEEE Trans. Power Electron., vol. 29, no. 8, pp. 4313–4321, Aug. 2014.
8. C. Buccella, C. Cecati, H. Latafat, and K. Razi, "Comparative transient response analysis of LLC resonant converter controlled by adaptive PID and fuzzy logic controllers," in Proc. IEEE Int. Conf. Ind. Electron. Soc., 2012, pp. 4729–4734.
9. H. Hu, X. Fang, F. Chen, Z. J. Shen, and I. Batarseh, "A modified high-efficiency LLC converter with two transformers for wide input voltage range applications," IEEE Trans. Power Electron., vol. 28, no. 4, pp. 1946–1960, Apr. 2013.
10. S. Wang, and M. K. Kazimierczuk "Frequency-domain analysis of series resonant converter for continuous conduction mode," IEEE Trans. Power Electron., vol. 7, no. 2, pp. 270–279, Apr. 1999.
11. H. Wu, Y. Li, and Y. Xing, "LLC resonant converter with semiactive variable-structure rectifier (SA-VSR) for wide output voltage range application," IEEE Trans. Power Electron., vol. 31, no. 5, pp. 3389–3394, May 2016.
12. H. Wu, X. Zhan, and Y. Xing, "Interleaved LLC resonant converter with hybrid rectifier and variable-frequency plus phase-shift control for wide output voltage range applications," IEEE Trans. Power Electron., vol. 32, no. 6, pp. 4246–4257, Jun. 2017.
13. X. Sun, X. Li, Y. Shen, B. Wang, and X. Guo, "Dual-bridge LLC resonant converter with fixed-frequency PWM control for wide input applications," IEEE Trans. Power Electron., vol. 32, no. 1, pp. 69–80, Jan. 2017.
14. H. Wang, Y. Chen, P. Fang, Y.-F. Liu, J. Afsharian, and Z. Yang, "An LLC converter family with auxiliary switch for hold-up mode operation," IEEE Trans. Power Electron., vol. 32, no. 6, pp. 4291–4306, Jun. 2017.
15. X. Wu, G. Hua, J. Zhang, and Z. Qian, "A new current-driven synchronous rectifier for series-Parallel resonant (LLC) DC–DC converter," IEEE Trans. Ind. Electron., vol. 58, no. 1, pp. 289–297, Jan. 2017.