

# Cost and Size analysis of Power Electronic Converter Based Transformer Used in Power Quality Conditioners

R. Priyadarsini and B. Dora Arul Selvi

Department of Electrical and Electronics Engineering, Anna University, Chennai, India

**Abstract :** Transformer plays a leading role in the Power System which performs many functions such as voltage transformation, electric isolation and in the power quality conditioners it is in the form of shunt and series transformer. Under low frequency operation, transformer is a bulky and an expensive component. Hence, Power electronics based transformer concept has grown up tremendously due to its flexibility, smaller size and more power handling capacity. Implementing the power electronics converter based transformer in to the power quality conditioners is easier if the analysis is made based on its size and its cost. This paper aims to analyze the core loss, winding loss (including eddy current loss), the weight of the active part of the transformer and its cost for the 50 Hz, 100 Hz and 150k Hz DVR injection transformer for different Power Electronic Transformer topologies for knowing its feasibility for the installation at power distribution. Computer Based Simulation has been carried out to know the effectiveness of the different topology schemes used in the DVR injection transformer as per the cost and size perspective.

**Keywords:** DVR, PET, Power quality conditioner, Transformer.

## I. INTRODUCTION

Dynamic Voltage Restorer (DVR) is one of the Power electronic converter based FACTS device which effectively reduces the power quality problems such as voltage sag/swell, unbalance & harmonics. It is designed to protect critical loads from the supply-side voltage disturbances and it is capable of generating or absorbing real and reactive power at its AC terminals [1]. DVR composed of an

injection transformer, an inverter, DC storage capacitor bank and a control and protection unit. The purpose of the Injection transformer in DVR is to inject the voltage and to reduce the voltage requirement of an inverter and it provides an electrical isolation between the inverter and the line and it prevents the DC storage capacitor from being shorted through switches in different inverter legs[2]. The size of the DVR depends on the size of the injection transformer. Hence, to reduce the size

of the injection transformer, various topologies have been taken for the analysis. Since, the trends in power supplies are towards miniaturization. Hence, Power Electronics based Transformer concept has been implemented in DVR injection transformer.

In general, an increase in switching frequency results in a smaller size of magnetic components [3]. Hence this analysis is made with the suitable core material for the injection transformer core. Many papers on transformers have been published but most of them deals with transformer design, reduction of loss, calculation of loss, or calculation of inductance [4-7]. So far there is no clear answer to the question concerning how much size and weight reduction can be achieved at high-frequency operation which leads to the reduction of the transformer cost. Hence there is a need for proper analysis to know the effectiveness of the proposed device.

Hence, this paper deals with a systematic analysis for the size and the weight versus the operating frequency for the high-frequency transformer based on the core and winding losses (including the eddy current loss), the weight of the active part of the transformer and its cost for the 50 Hz, 100 Hz and 150k Hz DVR injection transformer for different Power Electronic Transformer topologies. This calculation is proposed for the installation of power quality conditioners in

the power distribution system which will provides the feasible information for the corresponding topology.

## II. GENERAL ARCHITECTURE OF 100 HZ PET BASED DYNAMIC VOLTAGE RESTORER

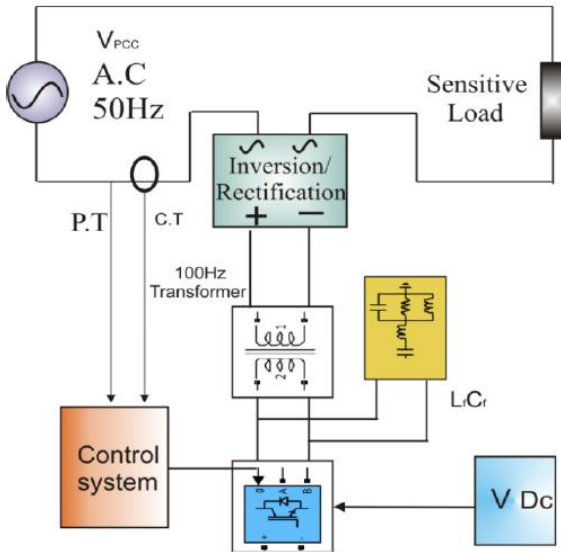

Fig. 2. Proposed DVR arrangement

The Fig.2 shows the 100 Hz Dynamic Voltage Restorer. Introducing bidirectional inversion and rectification module in the conventional DVR, is the most important modification

### A. Main Components of 100 Hz Transformer based DVR and its Rating:

Injection transformer is the main part of the DVR, which is changed with its rating with respect to its frequency. The Total Power Rating of the Power Electronics Transformer is depending on its parameters such as frequency, type of core etc. In this project 2 KVA DVR is analyzed

*Injection Transformer:* The injection transformer is connected in series with the line. When a sag occurs the required voltage is injected or added to the source voltage through the transformer. DVR mode of operation has an impact on the phase shift and its voltage drop, ie; it depends on the transformer parameters. A details of the injection transformer are presented here in Table: I.

in the 100 Hz PET based DVR. In this DVR, 100 Hz injection transformer is introduced instead of 50 Hz injection transformer without affecting the rating of power in the transformer. Thus the injection transformer size gets reduced, since the size of the transformer is inversely proportional to the frequency of operation.

Power quality problems such as voltage sag and swell's were detected by the traditional control technique and for injecting this additional compensating voltage, fixed DC voltage is given to the DVR inverter.

During normal voltage condition, the inversion / rectification module operates as rectification mode and the Thyristor conducts at  $0^\circ$  firing angle. Thus the output voltage of the module produces 100 Hz voltage, and this voltage is fed to the proposed injection transformer and its normal operating frequency is 100 Hz.

During the voltage swell or sag problems the inversion/rectification module act as inversion mode and the control system produces 100 Hz injection voltage that is fed to the input side of the transformer

Mode 1: Without any fluctuation in the source side the control system produces the signal which makes no conduction of inverter so there is no injection voltage fed to 100 Hz transformer. So the output voltage is same as the input voltage.

Mode 2: During the voltage swell this injection voltage opposes the input voltage and compensated voltage is fed to the load

Mode 3: During the voltage sag this injection voltage associate/adds to the input voltage and compensated voltage fed to the load.

*Transformer Design and Parameters:* At the start of compensation, the magnetic flux and current in the coil start at zero and then it gradually gets increase. It means that the transformer flux is approximately twice the maximum value of the normal flux. This causes an inrush current in transformer and that requires the transformer to be rated two times larger than a DVR. Thus, the transformer is large and expensive.

TABLE I  
INJECTION TRANSFORMER PARAMETERS OF DVR

Type	Single Phase, Core-Type Core
Frequency	100 Hz
Rated Power	2 KVA
Primary voltage	Rated 230 V
Secondary voltage	Rated 60 V

### B. Weight and Loss Analysis:

For analyzing the weight and loss of the DVR injection transformer for the 50Hz and 100Hz frequency, the following calculation are carried out and the results are tabulated below in Table: II, Table:III and Table: IV.

$$\text{Voltage per turn } E_t = 4.44 f \Phi_m = K \sqrt{Q} \quad (1)$$

$$E_t = 4.44 f B_m A_i \quad (2)$$

$$A_i \text{ is the net iron area } A_i = \frac{E_t}{4.44 f B_m} \text{ m}^2 \quad (3)$$

$$\text{Diameter of circumscribing circle } d = \sqrt{\frac{A_i}{K}} \quad (4)$$

$$\text{Gross core area } A_{gi} = \frac{A_i}{K_i} \quad (5)$$

$$\text{Width of the stamping } a = \sqrt{A_{gi}} \quad (6)$$

$$\text{Distance between core center } D=1.6a \quad (7)$$

$$\text{Width of the window (Ww)} = D-d \quad (8)$$

$$\text{Window area } A_w = \frac{Q}{2.2 \times 50 \times B_m K_w \delta A_i \times 10^{-3}} \quad (9)$$

$$K_w = \frac{8}{30+k_v} \text{ Transformer rating about 20 kV}$$

$$\text{Height of window } H_w = \frac{A_w}{W_w} \quad (10)$$

$$\text{Depth of the yoke } D_y = a \quad (11)$$

$$\text{Height of the yoke, } H_y = a \quad (12)$$

$$\text{Height of the frame } H = H_w + 2 H_y \quad (13)$$

$$\text{Length of the frame } W = D + a \quad (14)$$

$$\text{Weight of Iron } G_i = A_i l_i g_i \text{ (in kg)} \quad (15)$$

$$g_i = \text{Density of Iron / m}^3, \text{ kg}$$

$$l_i = \text{Mean length of flux path in iron}$$

$$\text{Weight of Copper } G_c = A_w k_w L_{mt} g_c \text{ (in kg)} \quad (16)$$

$$g_c = \text{Density of Copper / m}^3, \text{ kg}$$

$$L_{mt} = \text{Length of mean turns of a transformer winding}$$

$$\text{Total Core loss } P_i = \text{Hysteresis loss} + \text{Eddy Current loss} \quad (17)$$

$$\text{Hysteresis loss } P_h = K_h B_m^{1.6} f \quad (18)$$

$$K_h = \text{Hysteresis co-efficient}$$

$$\text{Eddy Current loss } P_e = K_e B_m^2 f^2 \quad (19)$$

$$K_e = \text{Eddy Current co-efficient}$$

$$\text{Total Copper loss } P_{cu} = I^2 R \quad (20)$$

$$\text{Total Power losses } P_{total} = P_i + P_{cu} \quad (21)$$

TABLE II  
DIMENSIONS OF THE 50HZ AND 100HZ DVR  
INJECTION TRANSFORMER

Dimensions	50 Hz	100 Hz
Net iron area $A_i$ (in $\text{m}^2$ )	$4.633 \times 10^{-3}$	$2.316 \times 10^{-3}$
Diameter of circumscribing circle $d$	0.076	0.0538
Gross Core Area $A_{gi}$ (in $\text{m}^2$ )	$5.148 \times 10^{-3}$	$2.573 \times 10^{-3}$
Width of the stamping 'a'	0.07175	0.0507
Distance between core center $D$ (in m)	0.11479	0.08112
Width of the window $W_w$ (in m)	0.0387	0.0273
Window area $A_w$ (in $\text{m}^2$ )	$4.4640 \times 10^{-3}$	$4.46499 \times 10^{-3}$
Height of window $H_w$ (in m)	$129.19 \times 10^{-6}$	$183.15 \times 10^{-6}$
Depth of the yoke $D_y$ (in m)	0.07175	0.0507
Height of the yoke, $H_y$ (in m)	0.07175	0.0507
Height of the frame $H$ (in m)	0.1436	0.10158
Length of the frame $W$ (in m)	0.18654	0.13182

TABLE III  
TRANSFORMER BASED LOSSES FOR THE 50HZ AND  
100HZ DVR INJECTION TRANSFORMER

Losses	50 Hz	100 Hz
$I^2 R$ loss ( $P_c$ ) or Copper loss	1.2% of output power	1.2% of output power
Hysteresis loss $P_h = K_h B_m^{1.6} f$	0.7 % of output power	0.4618 % of output power
Eddy Current loss, $P_e = K_e B_m^2 f^2$	0.5 % of output power	0.5% of output power
Total Power losses	2.4% of output power	2.1618% of output power

TABLE IV  
WEIGHT OF THE IRON AND COPPER REQUIRED FOR 50  
HZ AND 100 HZ DVR INJECTION TRANSFORMER

Weight (in kg)	50 Hz	100 Hz
Weight of Iron	80.586	40.284
Weight of Copper	11.69	11.69

### III. COMPARISON OF CONVENTIONAL DVR TRANSFORMER AND POWER ELECTRONICS TRANSFORMER (2 KVA)

Power Electronic Transformer (PET) is a new type of transformer grown with the power electronic technology, which is composed of Power Electronic Devices and a high frequency transformer. It works based on the concept that the transformer size is inversely proportional to the frequency of operation and flux density [8]. Hence a reduction in volume and weight of the transformer can be obtained by high frequency operation of the magnetic core. Fig. 3 shows the general block diagram of Power Electronic Transformer (PET).

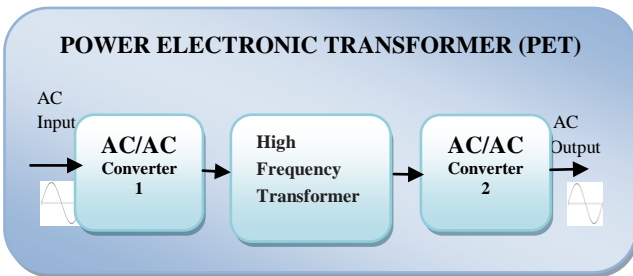

Fig. 3. General Block Diagram of Power Electronic Transformer (PET)

In order to find the amount of size reduction and cost reduction achieved by increasing the operating frequency from Hz to kHz, a complete calculation should take place by considering the following factors: the core size, core loss including the eddy current loss and the cost. In the next following sections from IV to VI, an analysis of Power Electronic transformer (PET) in kHz is carried out with 2 kVA power rating based on the core size, losses and the cost and a comparison is done to know the effectiveness of PET over the conventional DVR transformer.

### IV. CORE SIZE CALCULATION FOR PET

The first objective of this paper is to analysis the core size along with the losses of the PET over the conventional DVR transformer. For that in this section, the core size is calculated with Frequency 150kHz, Primary Voltage of the transformer 230V and secondary voltage of the transformer is 60V, with turns ratio 4:1, and for the 2 KVA rating.

#### A. Transformer Set up:

The SMPS topology is used as a transformer, which utilizes an H-bridge converter which is used to obtain high frequency AC voltage from the DC input voltage; moreover it produces the waveforms regarding the winding voltage and core-flux. The output of the H-bridge converter is connected to the primary side of the SMPS transformer and for obtaining the regulated DC output voltage of desired magnitude, secondary side voltage is rectified and filtered. Bi-directional current flow takes place through the transformer windings and the flux linking the windings also bipolar. The unregulated DC input bus voltage is often varies over a wide range. In order to regulate the output voltage, duty ratio 'D' of the switches are controlled within  $D_{min} < D < D_{max}$ . Under steady state condition, the required load voltage is equal to the average of the rectified secondary side voltage that is obtained by considering the voltage drops in the diode rectifier and the filter inductor and it can be assumed fixed to the output voltage  $V_o$ . Under dynamic condition, the average of the rectified secondary side voltage increases due to sudden change in load or supply voltage, the average DC output voltage on the secondary side may be remarkably more than its steady state voltage magnitude [9]. For calculating the peak flux  $\Phi$  in the core, the worst-case condition will correspond to the maximum duty ratio ( $D=0.95$ ) and maximum magnitude of the input voltage. The maximum duty ratio ( $D=0.95$ ) and the peak magnitude of the output (load) current ( $I_o$ ) will correspond to the worst-case current ( $I_i$ ) through the windings. Based on the inputs and outputs illustrated in Table V, the transformer may be designed as follows. The cost could significantly increases with low output voltage saving one diode drop.

TABLE V  
INPUT AND OUTPUT OF THE TRANSFORMER

Input Voltage AC (V)	Max output voltage DC (V)	Max output current DC (A)
230	60	33.3

## B. Magnetic Core Material, Shape and Size

Numeric codes were assigned by the manufactures for their cores to know their power-handling capability. A code is assigned to the core by this method is called area product,  $A_p$ . That is, it is the product of the window area,  $W_a$ , and the core cross-section,  $A_c$ . These codes are used by the core suppliers to summarize the dimensional and electrical properties in their catalogs [10], [11]. Ferrite cores are an oxide, commonly referred to as manganese zinc ferrites, which are made from Iron (Fe), Manganese (Mn), and Zinc (Zn). For the magnetic ferrite materials, the remarkable characteristics are high permeability, good temperature and low disaccommodation. The permeability of the material's are in the range of  $900\mu$  to  $10,000\mu$  and are available in different geometries such as triads, shapes and pot cores [11]. E-E shaped ferrite core is chosen. To know the size and dimension of the core,  $K_{gfc}$  (Core Design Parameter) needs to find out, after that select the core suitably [12].

$$K_{gfc} \geq \frac{\rho \lambda^2 I_{total}^2 K_{fe}^{\left(\frac{2}{\beta}\right)}}{4 K_u (P_{total})^{\frac{\beta}{\beta+2}}} * 10^8 \quad (22)$$

Where:

$K_{gfc}$  : Core Design Parameter

$\rho$  : effective wire resistivity ( $\Omega$  cm)

$I_{total}$  : Total rms winding current refer to the Primary (A)

$\lambda$  : Applied primary volt-sec (Volt - sec)

$P_{total}$  : Allowed total power dissipation (w)

$K_u$  : Winding fill factor

$\beta$  : Core loss exponent

$K_{fe}$  : Core loss coefficient  $W/cm^3 T^\beta$

$$\lambda = \int_0^{DT} V_d = DT V_d \quad (23)$$

The RMS currents can be expressed as in (24):

$$i_{s,rms} = \sqrt{\frac{\int_0^{2T} i_1^2(t) dt}{2T}} = \frac{n_2}{n_1} I_{o,max} \sqrt{D} \quad (24)$$

$$i_{1,rms} = i_{2,rms} = \sqrt{\frac{\int_0^{2T} i_2^2(t) dt}{2T}} = \frac{1}{2} I_{o,rms} \sqrt{1+D} \quad (25)$$

Determination of  $\frac{n_2}{n_1}$  as follows:

$$v_{o,avg} = \frac{n_2}{2n_1} D * V_d \quad (26)$$

Substitute the value of  $\frac{n_2}{n_1}$  in (24)

By using (25) the value of  $i_{1,rms}$  equal:

$$i_{1,rms} = i_{2,rms} \quad (27)$$

$$I_{total} = i_{s,rms} + 2 * \frac{n_2}{n_1} i_{1,rms} \quad (28)$$

Based on these,  $K_{gfc}$  for 150k Hz frequency for the suitable core selection is carried out with certain design variable and constants.

According to the value of  $K_{gfc}$ , the corresponding core type as in [17] is, EE70 / 6819 mm, and the dimensions chosen are for Cross-sectional area,  $A_c$ , Bobbin winding,  $W_A$ , Mean length per turn, MLT, Magnetic path length (Le), and Core weight.

## V. LOSS CALCULATION FOR PET

$$\text{Total Core loss } P_{fe} = K_{fe} (\Delta B)^\beta A_c L_e \quad (29)$$

$$\text{Total Copper loss } P_{cu} = \frac{\rho (MLT) n_1^2 I_{total}^2}{W_A K_u} \quad (30)$$

$$\text{Total Power losses } P_{total} = P_{fe} + P_{cu} \quad (31)$$

### A. Calculation of the Peak Flux Density $\Delta B$

$$\Delta B = \left[ 10^8 * \frac{\rho \lambda^2 I_{total}^2}{2 K_u} * \frac{MLT}{W_A A_c^3 L_e} * \frac{1}{\beta K_{fe}} \right]^{\left(\frac{1}{\beta+2}\right)} \quad (32)$$

Saturation flux density is approximately 0.4 T for ferrite.

### B. Calculation of the Transformation Ratio $\frac{n_2}{n_1}$

The transformation ratio can be calculated as follows [12].

$$n_1 = \frac{\lambda}{2\Delta B * A_c} * 10^4 \quad (33)$$

$n_2$  can be determined from (26)

Based on the above equations from the previous sections IV and V for the core size and loss calculations for the 150 kHz PET, calculations are carried out and the results are tabulated and for knowing the effectiveness of PET over the conventional DVR transformer comparison is done with the lower frequency DVR transformer, which is shown below in Table: VI.

TABLE VI  
COMPARISON OF PROPOSED DVR INJECTION TRANSFORMER BASED ON LOSSES AND WEIGHT OF THE TRANSFORMER FOR 50 HZ, 100 HZ AND 150K HZ POWER ELECTRONICS TRANSFORMER

Parameters	50 Hz	100 Hz	150k Hz
Total Core loss ( $P_i$ or $P_{fe}$ ) (in watts)	23.97	19.216	3.778
Total Copper loss ( $P_{cu}$ ) (in watts)	23.97	23.97	5.118
Total Power losses ( $P_{total}$ ) (in watts)	47.95W	43.19	8.89
Weight of Core (in kg)	80.586	40.284	2.8

## VI. COST ANALYSIS

The second objective of this paper is to analysis the total cost of active part of transformer which comprises the cost of copper used in the windings and the cost of the iron used in core. The cost of the copper in the windings and the cost of core will be calculated in Rs (Rupees) and therefore the total cost will also be in Rs (Rupees), the calculation is done based on the current market price of materials and the result with the comparison is tabulated in Table VII.

### A. Material Cost:

- The choice of core material- costlier CRGOS may be more economical, considering the over-all cost including that of copper.
- The choice of conductor materials- costlier copper may have to be used considering over-all performance and cost.

### For 50 Hz and 100 Hz DVR Injection Transformer

Core material: CRGOS with stacking factor,  $K_i = 0.9$ ; cost of iron/Kg = 150/-

Conductor material: copper; current density = 3 A/mm<sup>2</sup>; Cost of copper/Kg = Rs. 600/-

### For 150 kHz DVR Injection Transformer

Core material: Ferrite core; cost of iron/Kg = 420/-

Conductor material: copper; Cost of copper/Kg = Rs. 600/-

### B. Cost Estimation:

Cost of core = (Price per Kg. of core) x (weight of core)

Cost of copper = (Price per Kg. of copper) x (weight of copper)

TABLE VII  
COST COMPARISON FOR THE DVR INJECTION TRANSFORMER FOR 50 HZ, 100 HZ AND 150K HZ POWER ELECTRONICS TRANSFORMER.

COST	50 Hz	100 Hz	150k Hz
Total Cost of Iron	Rs. 12,087.9	Rs. 6,042.6	Rs. 1,176
Total Cost of Copper	Rs. 7,016.4	Rs.7,018.2	Rs.4,320
Total cost of DVR Injection Transformer	Rs. 19,104.3	Rs. 13,060.8	Rs.5,496

## VII. RESULTS AND DISCUSSION

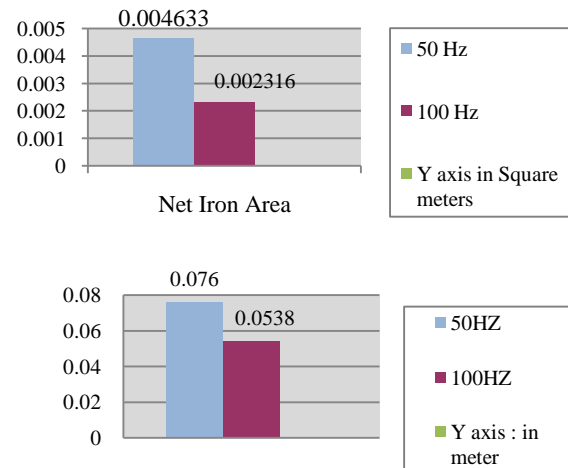

Fig. 7.1. Comparison of 50 Hz and 100 Hz DVR Injection transformer for the (a) net iron area (b) diameter of the circumscribing circle

The Fig.7.1 shows the comparison of 50 Hz and 100 Hz transformer of the DVR system. Based on the calculation for the net iron area, it is found that the net iron area for the 50Hz transformer is  $4.633 \times 10^{-3} \text{ m}^2$  and for the 100 Hz transformer it is  $2.316 \times 10^{-3} \text{ m}^2$  for that the result is shown in fig 7.1(a). Since the voltage per turn equation,  $E_t = 4.44 f \Phi_m = 4.44 f B_m A_i$ , from this equation, it is found that if the voltage is constant, the net iron area is inversely proportional to frequency, ie;  $A_i \propto \frac{1}{f}$ . Based on the calculations for the 50Hz and 100Hz DVR Injection transformer, it is clear that the net iron area predominantly gets decreased from  $4.633 \times 10^{-3} \text{ m}^2$  for the 50Hz to  $2.316 \times 10^{-3} \text{ m}^2$  for the 100Hz transformer with the increase in frequency. Therefore, the reduction in net iron area with the increase in frequency, the diameter of the core gets reduced.

Fig. 7.1 (b) shows the diameter of the circumscribing circle 'd' for the 50Hz and 100Hz DVR Injection transformer core, the value of 'd' for the 50Hz is 0.076m and for the 100Hz transformer it is 0.0538m. ie; while increasing the frequency, diameter of circumscribing circle of the transformer core gets reduced. This leads to the less usage of insulating material, also the length/one turn is less, so the amount of copper requirement is less for the windings. Due to the above reasons, the size, the weight and the cost of the transformer gets reduced while increasing the frequency.

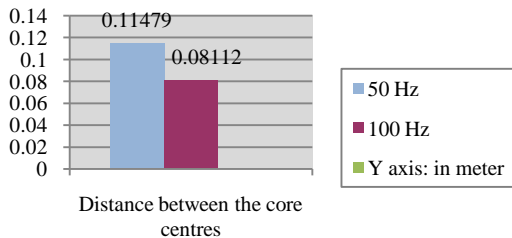
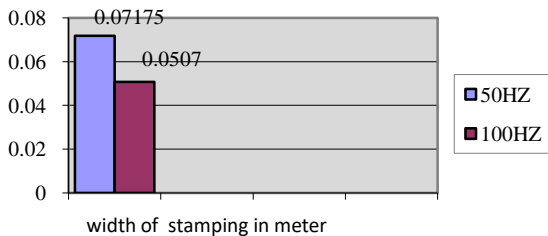

Fig. 7.2. Comparison of 50Hz and 100 Hz DVR Injection transformer for the (a) Width of the stamping (b) distance between the core centres

Fig. 7.2 (a) & (b) shows a comparison chart for the 50Hz and DVR Injection transformer, for the width of the stamping 'a' and for the distance between the core centres 'D'. Based on the calculations, for the 50Hz transformer core the width of the stamping is 0.07175m and for the 100Hz it is 0.0507m. Similarly, the distance between the core centres for the 50Hz is 0.11479m and for the 100Hz is 0.08112 m. Based on these results its clear that while increasing frequency the width of the stamping and the distance between the core centre gets reduced.

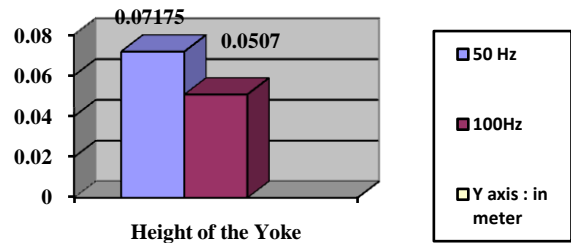
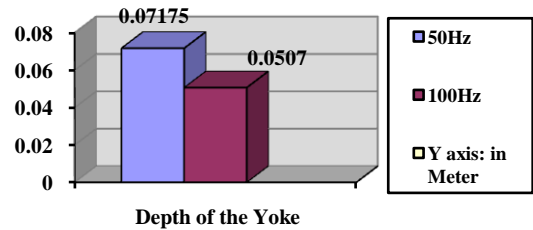

Fig. 7.3. Comparison of 50Hz and 100Hz DVR Injection transformer for the (a) Depth of the yoke (b) Height of the yoke

Fig.7.3(a) & (b) shows the diagrammatic representation for the depth of the yoke and for the height of the yoke. For the rectangular yoke, the depth of the yoke 'Dy' = depth of the core = width of the stamping 'a'. ie;  $Dy = a$ , and for the height of the yoke  $H_y = a$ ; as discussed in fig. 7.2 (a). Hence, for the 50Hz transformer core the depth of the yoke and the height of the yoke is 0.07175m and for the 100Hz it is 0.0507m. ; ie while increasing the frequency the depth of the yoke and the height of the yoke gets reduced.

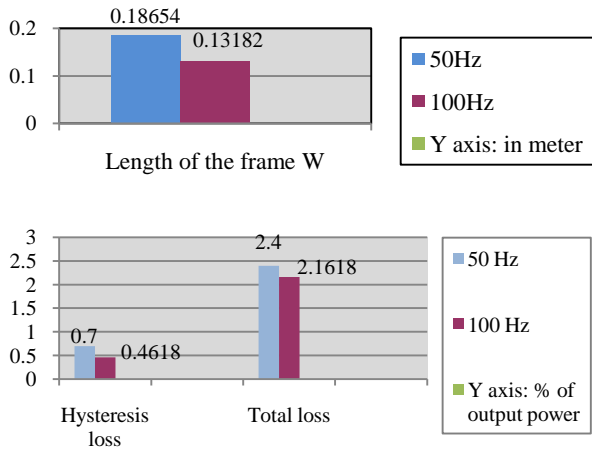

Fig. 7.4. Comparison of 50Hz and 100Hz DVR Injection transformer for the (a) Length of the frame 'W' (b) Hysteresis and Total losses

Fig. 7.4 (a) shows the chart for the length of the frame 'W' for the 50Hz and 100Hz DVR Injection transformer, based on the calculation, length of the frame for the 50 Hz transformer is 0.18654m and for the 100Hz transformer it is 0.13182m.

Fig. 7.4 (b) shows the chart for the hysteresis loss and the total loss, based on calculation, hysteresis loss is 0.7 % of output power and 0.4618 % of output power for the 100Hz transformer. So that, the total loss for the 50Hz transformer is 2.4% of the output power and for the 100Hz transformer it is 2.1618% of output power. Voltage and Current at both 50Hz and 100 Hz transformer are same and hence output and  $I^2R$  loss in both cases are same. Therefore, it's clear that while increasing the frequency, the length of the frame ie; overall length of transformer gets reduced, moreover the hysteresis loss also gets reduced and hence total loss reduced significantly.

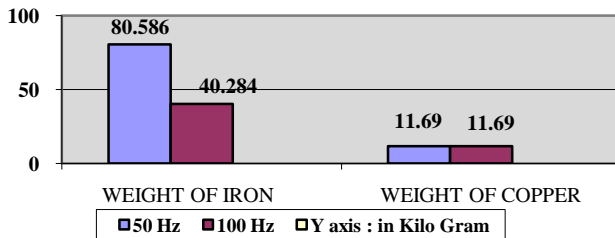

Fig. 7.5. Comparison of 50Hz and 100Hz DVR Injection transformer for the Weight of iron and Weight of copper

Fig. 7.5 shows the chart for the Weight of iron and Weight of copper for the 50Hz and 100Hz DVR Injection transformer. Based on the calculation, Weight of iron for the 50Hz transformer is 80.586 kg and for the 100Hz

transformer it is 40.284 kg. Therefore, its cleared that weight of the iron gets reduced while increasing the frequency.

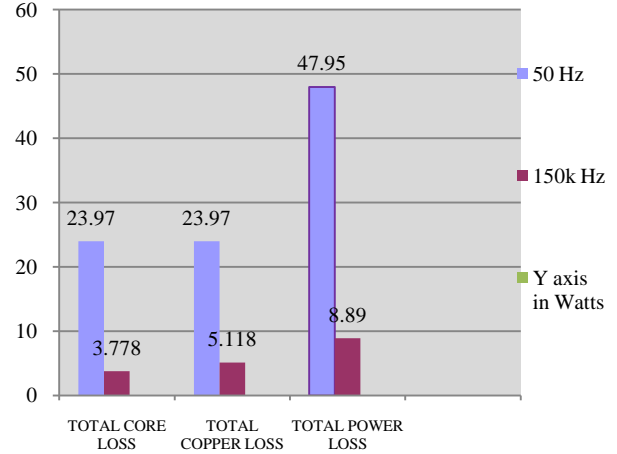

Fig. 7.6. Comparison of 50Hz and 150k Hz DVR Injection transformer for the Total core loss, Total copper loss and Total power loss

Fig. 7.6 shows the chart comparing the 50Hz and 150kHz DVR Injection transformer. Based on the calculations done for the 150k Hz high frequency transformer the total core loss obtained is 3.778 W and the total copper loss obtained is 5.118 W and thus the total power loss obtained is 8.89 W. ie; while comparing to the 50Hz which having total core loss as 23.97 W, and for the total copper loss it is 23.97 W and thus the total power loss 47.95 W. Based on the results it's clear that the while increasing the frequency from Hz to Kilo-Hertz the core loss, copper loss gets reduced and thus the total power loss reduced significantly.

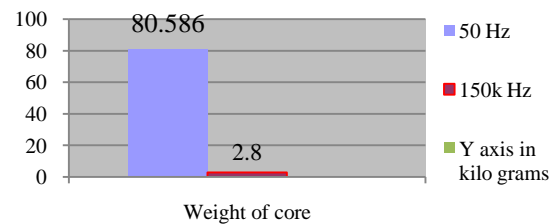

Fig. 7.7. Comparison of 50Hz and 150k Hz DVR Injection transformer for the Weight of the core

Fig. 7.7 shows the chart comparing the weight of the core for the 50Hz and 150k Hz DVR Injection transformer. Based on the calculations the weight of the 50 Hz transformer is 80.586 kilograms and for the 150k Hz transformer, it is 2.8 kilograms. From the result, it's clear that the weight of the core gets reduced while increasing the frequency from Hz to Kilo-Hertz.



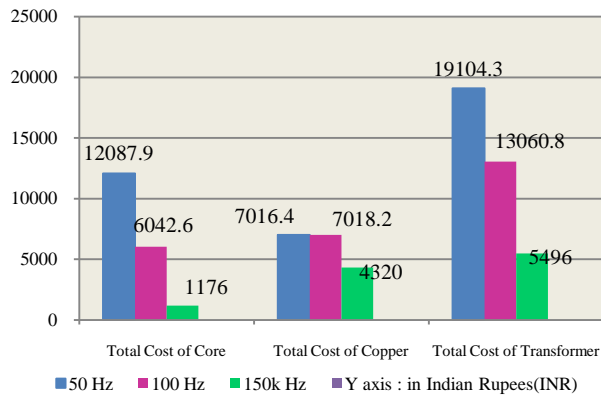

Fig. 7.8. Cost Comparison of 50Hz, 100 Hz and 150k Hz DVR Injection transformer for the Total Cost of Core, Total Cost of Copper and Total Cost of DVR Injection transformer

Fig. 7.8 shows the chart for the cost analysis for the 50Hz, 100 Hz and 150k Hz DVR Injection transformer. Based on the calculations the Total cost of core for the 50 Hz transformer is Rs. 12087.9/- and for the 100 Hz it is Rs. 6042.6/- and for the 150k Hz it is Rs. 1176/-. Similarly, the Total cost of copper for the 50Hz transformer is Rs. 7016.4 /- and for the 100 Hz it is Rs. 7018.2 /- and for the 150k Hz it is Rs. 4320 /-. Thus the Total cost of the DVR Injection transformer for the 50Hz transformer is Rs. 19,104.3 /- and for the 100 Hz it is Rs. 13,060.8 /- and for the 150k Hz it is Rs. 5496 /-. From the results, it's clear that while increasing the frequency of the transformer the cost of the transformer gets reduced.

## VIII. CONCLUSIONS

Thus, this paper provides an analysis for different Power Electronic Transformer topologies based on the calculations for the cost and size of a DVR injection transformer for the installation and to improve the easy selection. A theoretical comparison and Computer Based simulation is made for the 50 Hz, 100 Hz and 150k Hz DVR injection transformer based on the core loss, winding loss including eddy current loss, the weight of the active part of the transformer and its cost. This complete analytical results reveal that the proposed higher frequency system, reduces the loss, size and hence the cost of the DVR Injection transformer, when compared to the lower frequency conventional DVR Injection transformer, which results in smaller transformer size which is feasible to implement in power quality conditioners where size and cost is a big constraint.

## REFERENCES

- [1] A. Ghosh and G. Ledwich, "Compensation of distribution system voltage using DVR", IEEE Transactions on Power Delivery, vol.17, Issue no. 4, Page(s): 1030 – 1036, Oct 2002.
- [2] Ahmed M.Saeed, Shady H.E, Abdel Aleem, Ahmed M.Ibrahim, Murat E.Balci, Essam E.A, El-Zahab; "Power conditioning using dynamic voltage restorers under different voltage sag types", Journal of Advanced Research, Volume 7, Issue 1, Pages 95-103, January 2016.
- [3] V. Bolborici, "Design of low profile transformers for high frequency operation", Graduate Department of Electrical and Computer Engineering University of Toronto, 1999.
- [4] C.Jamerson, Core loss calculations, *Power Electronic Technology*, Vol. 28, No. 2, Feb. 2002, pp. 14–24.
- [5] W. G. Hurley and W. H. Wölfle, *Transformers and Inductors for Power Electronics: Theory, Design and Applications*. Wiley, 2013.
- [6] M. A. Bahmani, E. Agheb, T. Thiringer, H. K. Hidalen and Y. Serdyuk, "Core loss behavior in high frequency high power transformers - i: Effect of core topology," *Journal of Renewable and Sustainable Energy*, vol. 4, no. 3, 2012.
- [7] Sippola M., Sepponen R., "Accurate prediction of High Frequency Power Transformer Losses and Temperature rise", *IEEE Transactions on Power Electronic*, vol. 17, no. 5, September 2002
- [8] D. Wang, C.X. Mao, J.M. Lu, S. Fan, and F. Peng, "Theory and application of distribution electronic power transformer," *Electric Power Systems Research*, vol. 77, no. 3, pp. 219-226, 2007.
- [9] D. R. Stark, "Compact isolated high frequency DC/DC converters using self-driven synchronous rectification", M.S.dissertation, Dep.Electr., Virginia Polytech, Blacksburg, Dec 2003.
- [10] M. Rylko, K. Hartnett, J. Hayes and M. Egan, "Magnetic material selection for high power high frequency inductors in dc-dc converters," in *Applied Power Electronics Conference and Exposition, 2009*, pp. 2043–2049, Feb 2009.
- [11] M. Dekker, "Transformer and Inductor Design Handbook", third edition, colonel wrn. t. mclyman California, U.S.A, p., 2004.
- [12] E. Robert W. Maksimovic, Dragan, "Fundamentals of power Electronics transformer Design", Springer US, 883, 2001.
- [13] Raju Basak, Arabinda Das and Amar Nath Sanyal, "Optimal Design of a 3-Phase Core Type Distribution Transformer Using Modified Hooke and Jeeves Method", *TELKOMNIKA Indonesian Journal of Electrical Engineering*, Vol. 12, No. 10, pp. 7114 – 7122, October 2014.
- [14] Available at : <https://www.bestofelectricals.com/copper-wire-8-no-4m-m>, accessed august 2018.