

A NOVEL VOLTAGE STABILITY INDICATOR FOR LOSS MINIMIZATION IN DISTRIBUTION SYSTEM USING RECONFIGURATION

P. SUNDARARAMAN¹ T. MENAKADEVI²

¹Research scholar, Anna University, Chennai, India.

Phone: 9443625263, Email:sundararaman72@gmail.com

²Professor, Department of ECE, Adhiyaman College of Engineering, Hosur, India

Phone: 9629350444, Email:menaka_sar@rediffmail.com

C. KUMAR³

³Senior Professor, Department of EEE, Sri Ranga Poopathi College of Engineering, Gingee, India.

Phone: 9443266567, Email: drckumar.arimalam@gmail.com

Abstract: This paper presents a novel technique for loss minimization in distribution systems with a voltage stability indicator (VSI). A new VSI is modeled by considering distribution system losses. This VSI is used to improve the system stability parameters, reduce distribution loss and to find the maximum loadability limit of the various distribution conductors. Network reconfiguration is implemented using minimum branch current method and minimum voltage difference method. The proposed technique is tested on IEEE 33 bus and an India real time system of 62 bus using MATLAB software environment. The simulation results are presented to demonstrate the effectiveness of the proposed VSI.

Key words: Radial Distribution Systems (RDS), Loss Minimization, Power Flow Maximization, Voltage Stability Indicator (VSI), Load Multiplication Factor (LMF).

1. Introduction

In recent years, the consumption of electricity power has drastically increased and hence the increased. The Distribution system is based on unconditional load on different lines [1 and 2]. The operation and control the distribution system is more complex and very tough particularly in the area which is heavily populated. This leads to insufficiency. Nearly 30% to 37% of the supply is lost in the distribution system due to the improper conductors placed between the substations and improper coordination of protective systems. It is the prime duty of the researchers and planners to find the solution for minimizing the losses and limit point voltage stability. The aim of a line stability indicator is to detect the system loadability. In distribution lines, resistance and inductance ratio are equal or more or less the same and unidirectional power flows from the substations. Reduction of the power loss is more problematic and critical to maximize the power flow capacity of the lines and traditionally reconfiguration is obtained to reduce the loss. If voltage stability is not properly maintained it would probably lead to voltage instability or voltage collapse. The topological structure

of radial system is reconfigured for improving the voltage stability, increasing the power flow and minimizing the losses in the distribution lines.

The system reconfiguration of radial distribution systems for reducing the line loss used different voltage stability indicators more over this shows a stability index by Thevenin's method of derived equations and second order Newton Raphson load flow technique has been developed. Newton Raphson method of load flow analysis is only suitable for transmission system but not for distribution system [3]. The π method for modeling and the distribution systems line parameters are considered lumped variation of reactive power only. The above method is not suitable because load is not lumped variation, but slow variations of loads in distribution systems are advisable [4]. The load flow technique which forms the Jacobean matrices, utilized to find the P_{mg} by slack node conventional method and considers all voltage and frequency characteristics of the generator, governor, and loads [5]. The performance index of a single contingency depends upon the small level load variations, distribution systems are not depended upon the single contingency analysis [6].

The complicated solution of the stability index, leads to the variation of load of the system is multiplied by λ factor [7]. The stability index for optimal transmission path and circuit vector calculation method using the Jacobian matrix is without considering path constraints and consider only the determinant of deviation of voltage direct axis component [8]. The stability indicator calculation without taking the reactive power losses and unimportant to produce reactive components [9]. This paper developed voltage stability index in geometrical method relationship with the change of power losses due to the branch exchange method. The loss reduction depends upon the radius of the circle, which is not suitable for minimum loss reduction, the points are negative [10]. The conventional Fast Voltage Stability Index (FVSI) is based on the conventional method and does not include the losses for the calculation purposes and systems

loads can be increased by the factor of 25% as bulk [11], the stability index for the distribution system, which is different from the transmission systems. In transmission systems line parameters are $X \gg R$ but in distribution system R, X are almost equal, but practically distribution systems are unbalanced loads, and calculated based on the constant power, constant current and constant impedance [12]. The Index based upon the shunt admittances of the lines in distribution systems, the systems is having no shunt elements, even though, it is considered as negligible [13]. The stability indicator by using load and did not consider the loss in the lines moreover he used singular value of Jacobean 3. matrixes utilized for the calculation [14].

The challenge in the new proposed a novel VSI method is the task of finding all the components of 50 Hz system of active power flow, reactive power flow, voltages and the angles of the each line. It is found that main loss in the OH system, namely copper loss and cable loss.UG system in the function of current. This loss can be reduced by network reconfiguration. The main advantage of network reconfiguration is that it improves voltage stability, regulates the peak demand, and increases the network reliability that is more practical and efficient. Increasing the voltage stability can be achieved without any additional cost, by Tap changing transformer associated with switches.

The proposed a novel VSI has been utilized for the load flow solutions. The three methods in exhaustive search techniques are needed to manage optimal switching configurations of test systems. It is observed that the usage of switches (tie, sectionalized) for opening and closing the interconnection, altering the system topology allows the transfer of load from stronger feeder to the other. This reconfiguration of a radial distribution networks to optimize the power distribution processes in the feeder and to improve the voltage profile.

Section 2 discusses the proposed stability indicator; section 3 deals with the network reconfiguration, section 4 discussed the simulation results and discussions, section 5 deals with the prediction of the power flow capacity of distribution lines based on the new VSI and section 6 conclusions.

2. Proposed Voltage Stability Indicator

A novel voltage stability indicator is proposed for the three phase radial distribution network assumed to be balanced and drawn as a single line diagram. The number of lines in a power system is usually higher than the number of buses as to assure power delivery to main load centers and to improve system reliability and stability ensuring the security. Power flow in a radial distribution network described by a set of recursive equations is called Distributed load flow equations which analysis from the beginning at the last branch and finishing at the first branch of the feeder that gives the real power, reactive power, voltage in sending end

of all branches and voltage in receiving end. Normally those branch exchange method is one of the superior methods is used to determine the active power, reactive power, voltages and angles in all the buses and to find the active power loss and reactive power loss of the distribution lines.

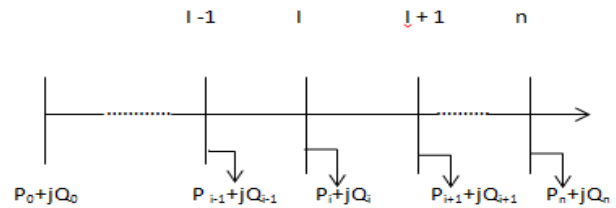

Fig. 1. Single line diagram of a distribution network

Fig. 1 show the single line diagram of a distribution network. Load flow equations carried out by branch exchange methods of recursive equations that can be applied to the system by using forward backward sweep algorithm to determine the real power losses, reactive power losses, and voltages in sending end, receiving end [2]. The modified Barans method, which reduces a large radial distribution network into a simple single network, simplifies the length of calculation of unreduced network.

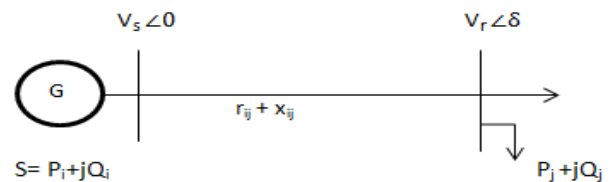

Fig. 2. Single line diagram of two bus system.

Fig.2 shows the two bus system. The line connects bus i and j and it is modeled as a series resistance with inductive reactance as line constants. The three phase distribution network is 'n' bus system used to establish a relationship between the sending, receiving end voltages and powers. It is assumed to be balanced and has been represented by a single line diagram. A source is connected at the sending end and the load is connected at the receiving end. From the network reconfiguration of the current flow through the transmission line from sending to receiving as a simple equation computed as assumption of two factors, one is sending end voltage angle is zero and the other receiving end voltage angle is δ .

Let us assume bus 'i' is a reference bus, then the current, I_{ij} is calculated by

$$I_{ij} = \frac{V_i \angle 0 - V_j \angle \delta}{r_{ij} + jx_{ij}} \quad (1)$$

The apparent power of the line and active and reactive power flows have been calculated from the

current flow equation

$$S_j = V_j * I^* . I_{ij} = \left[\frac{S_j}{V_j} \right] \quad (2)$$

By using the receiving powers, the current is also determined by

$$\frac{P_j - Q_j}{V_j^* \angle -\delta} = I_{ij} \quad (3)$$

The above, the equations are current equations from the apparent power and active power and reactive power flows

$$P_i^k = |I_{ij}^2| * r_{ij}, Q_i^k = |I_{ij}^2| * x_{ij} \quad (4)$$

The losses of the transmission lines have been calculated from the equations

$$P_L = |I_{ij}^2| * r_{ij} = \frac{P_i^2 + Q_i^2}{V_i^2} * r_{ij} \quad (5)$$

$$Q_L = |I_{ij}^2| * x_{ij} = \frac{P_i^2 + Q_i^2}{V_i^2} * x_{ij} \quad (6)$$

Power losses have been calculated from the individual lines and the net injected active and reactive power of the source node is the sum of the total power demand and the total distribution losses in the lines

$$P_i = \sum_{k=1}^{nl} P_i^k, Q_i = \sum_{k=1}^{nl} Q_i^k \quad (7)$$

$$P_i = \sum P_i + \sum P_L, Q_i = \sum Q_i + \sum Q_L \quad (8)$$

With a few manipulations, the new complex equations are expressed as

$$\{(P_j + jQ_j)(r_{ij} + jx_{ij}) = (P_i + jQ_i)(r_{ij} + jx_{ij}) - I_{ij}^2(r_{ij} + jx_{ij})(r_{ij} + jx_{ij})\} \quad (9)$$

From T.K.A.Rahman the new voltage equation is compared with

$$(P_j r_{ij} - Q_j x_{ij}) + j(P_j x_{ij} + Q_j r_{ij}) = (P_i r_{ij} - Q_i x_{ij}) - j(P_i x_{ij} + Q_i r_{ij}) + I_{ij}^2(r_{ij}^2 - x_{ij}^2) \quad (10)$$

Separating the real and imaginary parts gives

$$(P_j r_{ij} - Q_j x_{ij}) = (P_i r_{ij} - Q_i x_{ij}) + I_{ij}^2(r_{ij}^2 - x_{ij}^2) \quad (11)$$

The above equations are voltage equations compared with below equations

$$V_i * V_j \cos \delta - V_j^2 \quad (12)$$

$$-V_i V_j \sin \delta = x_{ij} * P_j - r_{ij} * Q_j \quad (13)$$

Comparing the above equations, Assume

$$V_i = 1.0 \text{ pu and } \delta \text{ is small } \cos \delta = 1$$

$$V_j^2 - V_j + (P_i r_{ij} - Q_i x_{ij}) + (P_j^2 - Q_j^2)(r_{ij}^2 - x_{ij}^2) = 0 \quad (14)$$

simplifying the quadratic equation have real roots are determined the stability of any systems

$$V_j = \frac{1 \pm \sqrt{1 - 4((P_i r_{ij} - Q_i x_{ij}) + (P_j^2 - Q_j^2)(r_{ij}^2 - x_{ij}^2))}}{2} \quad (15)$$

The quadratic term of right-side of the equation is always positive and its value is very small as compared to other part of the equation.

$$1 - 4 * ((P_i r_{ij} - Q_i x_{ij}) + (P_j^2 - Q_j^2)(r_{ij}^2 - x_{ij}^2)) \geq 0 \quad (16)$$

The value of $\Delta = \sqrt{(b^2 - 4ac)}$ is discriminated to zero, the inner term of the value $\sqrt{(b^2 - 4ac)}$ must be zero value. In this equation $4ac = 1.V_j$ Varies from zero to one, and it produces multiple indicators due to the real roots limits. The limitation is called as stability indicator. If the limitation is below one and above zero, the voltage stability is compromised.

The real root is the only term to determine the stability of all the systems. If the system is stable, they must have the real negative roots. This shows the stability of the system is always depended on its line losses in which, if the power losses are increased, the stability indicator values also increases. When the line losses are minimized the stability value lies in-between 0 to 1 and hence voltage stability is maintained in the distribution lines.

The new voltage stability indicator equation is

$$4 * ((P_i r_{ij} - Q_i x_{ij}) + (P_j^2 - Q_j^2)(r_{ij}^2 - x_{ij}^2)) = 1 \quad (17)$$

The value of the new stability indicator is known as new VSI. As well as the deficiency of reactive power is also from the equation

$$\text{VSI} = 4 * ((P_i r_{ij} - Q_i x_{ij}) + (P_j^2 - Q_j^2)(r_{ij}^2 - x_{ij}^2)) = 1 \quad (18)$$

The relation between voltage stability and power losses are derived to show that voltage stability can be improved by minimizing the power losses in system

$$\text{VSI} = 4 * ((P_i r_{ij} - Q_i x_{ij}) + (P_j^2 - Q_j^2)(r_{ij}^2 - x_{ij}^2)) \quad (19)$$

r_{aj}, x_{ij} are Line resistance and inductance, P_i, Q_i are the active and reactive power flow in sending end, P_j, Q_j are active and reactive power flow in receiving end. P_L, Q_L are the active and reactive power losses. Many research papers are formed the different equations for the stability are voltage stability index, line loadability index, load balancing index, proximity indicator, and loss sensitivity factor, and so on.

This paper will give the new voltage stability indicator include the both active and reactive power losses. Distribution losses are the major role to play the stability of power systems. In this VSI is the new tool for the finding the system parameters. It is very clear that depending upon the many constraints, the system is ideally stable when VSI is lies from 0 to 1, unstable means VSI lies more than 1 and below than 0. If the system is unstable, the performance condition is out of boundaries, then the system will reaches to unstable. Due to heavy loads, the lines are most likely to be collapsed. The VSI should be more than 1 or below 0 and negative value of VSI leads to systems becoming unstable or collapse.

3. Network Reconfiguration

Network reconfiguration means restructuring [1] the power lines which connect various loads in a power system. Restructuring the specific lines leads to alternate system configurations. System reconfiguration can be accomplished by placing interconnected switches into network. Based on the VSI equation derived, opening and closing the switch connects or disconnects the lines in the existing network. Network reconfiguration is performed by opening the sectionalizing (Normally closed) switches and closing tie (Normally open) switches. If the placement of these switches tends to change, then it leads to a change in the entire network topology. These switching are performed in such a way that the radially of the network is maintained and all loads are energized. By closing the tie switches in radial system, this network transforms in to fully meshed systems. In this condition power losses are decreased. This is the least power losses of the system. The function of sectionalized switch is to open the lines between the buses in a loop to restore the radial system. Finally there are 'N' no of loops in the system it should have 'N' no of sectionalized switches in the distribution systems finally.

While applying reconfiguration techniques with the VSI equation derived, the tie switch has to be closed on the other hand, sectionalized switch has to be opened in the loop created, which restores the radial configuration. If the switch pairs are chosen through exhaustive formula, then there is an increase in the total losses. The reason is the radial distribution network represented by several loops. This is because, when it is connected, one tie line can only make one loop, the number of loop is equal to the number of lines. The benefits of the feeder reconfiguration is to restore the power to any outage partition of a feeder, relieving over load on a feeder by shifting the loads in real time nearby feeders and reducing the resistive losses. Optimal reconfiguration involves the selection of the best set of branches to be opened, one each from each loops, for reducing resistive line losses, and relieving overloads on feeders by shifting the load to feeders. This method is most suitable for the radial distribution systems. The distribution in losses can easily be computed from the results of two load flow studies one is Newton Rap son method and distributed load flow studies using forward backward sweep algorithm to determine the distribution losses, and voltages of all the buses. The best method of reconfiguration has been analyzed before and after the feeder reconfiguration. The power flow studies of both

the cases are modeled using the branch exchange method of finding the best possibility of different reconfiguration solutions are tabulated. The real data of the distribution lines have been collected and implemented after running the distributed power flow equations using MATLAB software. Network reconfiguration is done based on the result of power flow equations, opening the sectionalized switches and closing the tie line switches. The method which is best suitable for loss reduction has been identified and the best possible switching positions are also tabulated.

3.1. Minimum Branch Current Method

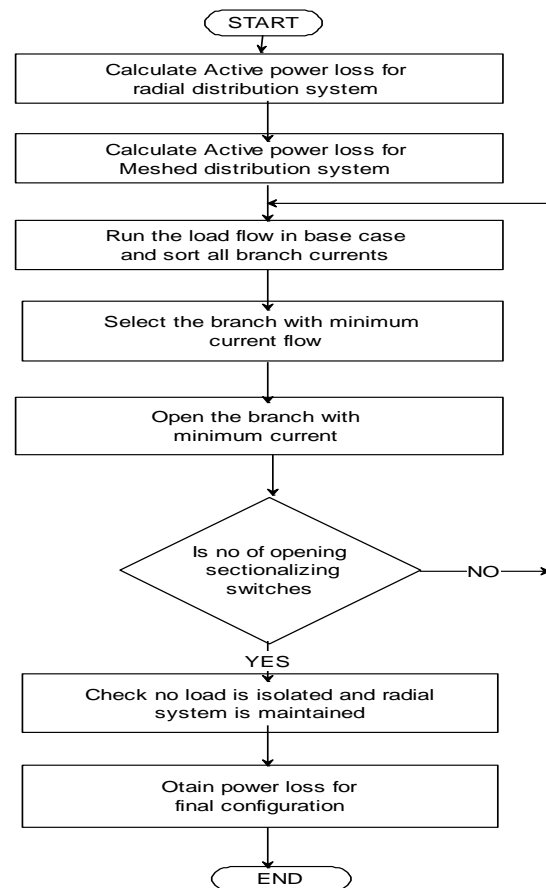

Fig.3. Flow chart of minimum current flow method.

Fig.3 shows the flowchart of the minimum branch current flow method. It is used to find the minimum current flow and to open the sectionalized switches and closing the tie switch where the minimum current flow through the lines and the structure is radially restored or maintained. It is not possible to open/closing the switches in heavy current flow lines, which requires current limiting equipment, protective devices and improper coordination of lines may occur. This leads to voltage uncertainty will occur in the lines. So the minimum current flow method is best for open / closes the switches for network reconfiguration methods.

3.2. Minimum Voltage Drop Method

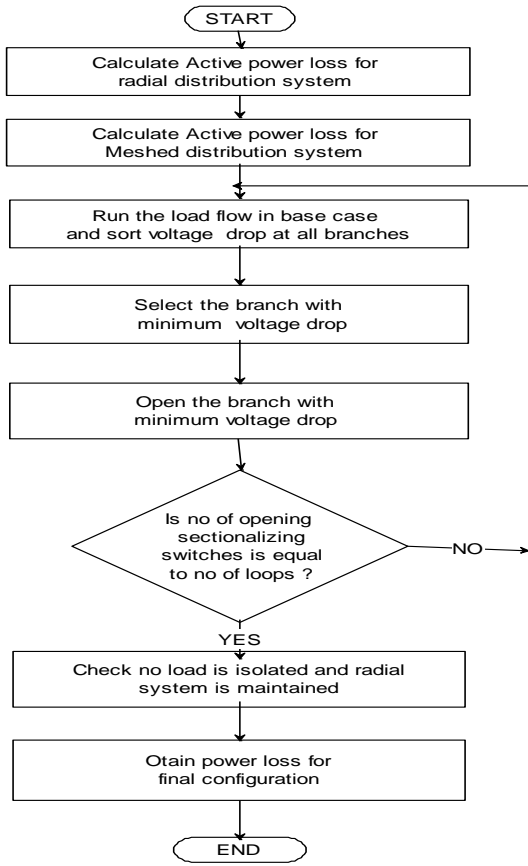

Fig.4. Flowchart for minimum voltage difference method

Fig 4 shows the flowchart of the minimum voltage drop between the lines. It is used to find the branch where the minimum voltage drop occurs between the lines is identified and to open the sectionalized switches and closing the tie switch and to maintain the radial structure. It is not possible to open/closing the switches in heavy voltage between the terminals of lines, which requires voltage absorber; voltage controller equipment's and safety measures. The minimum voltage drop method is more suitable for opening/closing the switches in network reconfiguration techniques.

4. Evaluation of Voltage Stability Limit

The new voltage stability indicator from the above equations mentioned to find the exact point of maximum loading point of distribution lines.

$$VSI = 4 * \left((P_i r_{ij} - Q_i x_{ij}) + (P_j^2 - Q_j^2)(r_{ij}^2 - x_{ij}^2) \right) = 1 \quad (20)$$

It is very clear that based on many constraints, it would be ideally stable when VSI lies from 0 to 1, the system is purely stable. When the system is unstable, the VSI is more than 1 and below 0. The VSI lies between 0 and 1 for a given the maximum power transfer capacity of distribution line. The system is unstable, the performance characteristics are out of boundaries, if

exceeds it may collapse.

The number of lines in power system is normally higher than the number of buses. It is used to improve system reliability and stability, thereby ensuring the security. since it is heavy loaded, the chances are easy to collapses or outage. So system will be unstable or collapse. Studying the maximum transfer of apparent power of the line can prevent before it gives collapsed.

Table. 1. Loadability of RACCOON and BEAVER conductors for different power factor

LMF	RACCOON			LMF	BEAVER		
	VSI				VSI		
	0.85 PF	0.90 PF	0.95 PF		0.85 PF	0.90 PF	0.95 PF
1.0	0.218	0.175	0.136	1.0	0.238	0.193	0.154
4.145	0.999	-	-	3.78	0.998	-	-
5.04	-	0.999	-	4.56	-	0.999	-
6.33	-	-	0.998	5.58	-	-	0.999

Table 1 shows the results of accurate point loadability limit using the new VSI indicator for the various conductors. After the distributed load flow executed, based on the results, when Raccoon conductor at 0.95 pf lagging of LMF is 6.34, if the LMF is increased 0.001 of load 6.341 times the system will go to unstable regions of RACCOON type of conductor. The prediction of stability point of load is 6.34 of LMF. Beaver conductor at 0.95 pf lag of LMF is 5.58.

Table. 2. Loadability of RABBITTE and WEASEL conductors for different power factor

LMF	RABBITTEE			LMF	WEASEL		
	VSI				VSI		
	0.85 PF	0.90 PF	0.95 PF		0.85 PF	0.90 PF	0.95 PF
1.0	0.225	0.191	0.160	1.0	0.431	0.380	0.334
3.90	0.999	-	-	2.11	0.998	-	-
4.55	-	0.998	-	2.37	-	0.998	-
5.37	-	-	0.999	2.86	-	-	0.999

Table 2 shows the results of accurate point loadability limit using the new VSI indicator for the various conductors. After the distributed load flow executed, the Rabbit conductor at 0.95 pf lag of LMF is 5.37 and Weasel conductor at 0.95 pf lag is 2.68 times. The proposed VSI is used to predict the exact point of maximum loadability limit (voltage stability point) 70.0% (4.43 LMF to 6.34 LMF) distribution lines and power flow capacity of various conductors using different power factors like 0.85, 0.9 and 0.95 lagging are given below.

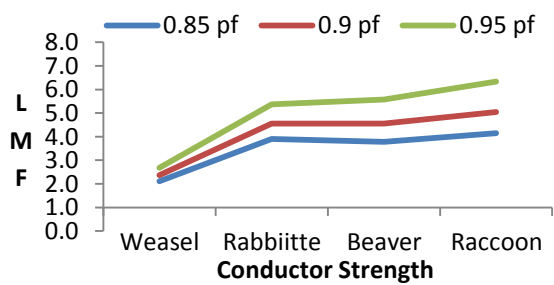

Fig. 6. Various conductors' strength for different power factor

Figure 6 shows the capacity of apparent power flow which depends on the line resistance, reactance and losses. But practically the cost of the line depends upon the distance. The distribution lines apparent power flow depends upon the resistance and inductance, length, spacing, span and the area of the cross section of ACSR conductors. Based on the above results a new voltage stability indicator VSI effectively identifies the maximum apparent power flow capacity of conductor is accurate. The breaking point of the lines and stability point are easily identified through the novel VSI. Network reconfiguration gives minimum power loss. Then stability indicator gives the voltage stability point of distribution lines.

5. Simulation results and discussions

The Vellore distribution circle is the largest load center in Tamilnadu. The system under study is three of 11 KV networks under Tamilnadu Electricity board (TNEB) where of 10 MVA, 0.95 lagging of power transformers installed. The incoming lines are 33 KV. Outgoing liners are 11 KV and the conductor size is 91.97mm². The ACSR conductor is a distribution of overhead systems with radial networks.

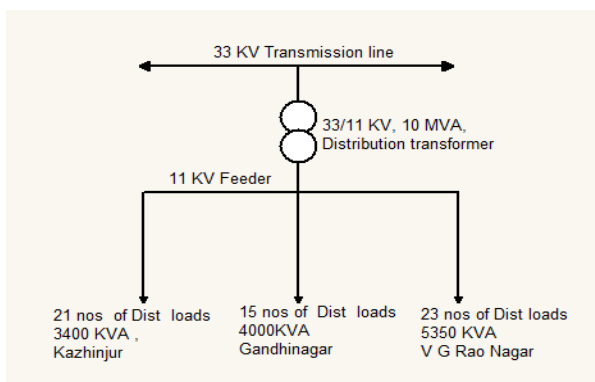

Fig. 7, Real time system (62 buses)

Fig 7 shows the real time system of simple distribution system. There are three tie lines before network reconfiguration because of voltage reduction, long length and overloaded lines in the existing radial distribution system. The minimum operating voltage is

nearly 9 KV in the existing system. The distribution system with tie lines and meshed topology are demonstrated that are shown in fig 8 given below.

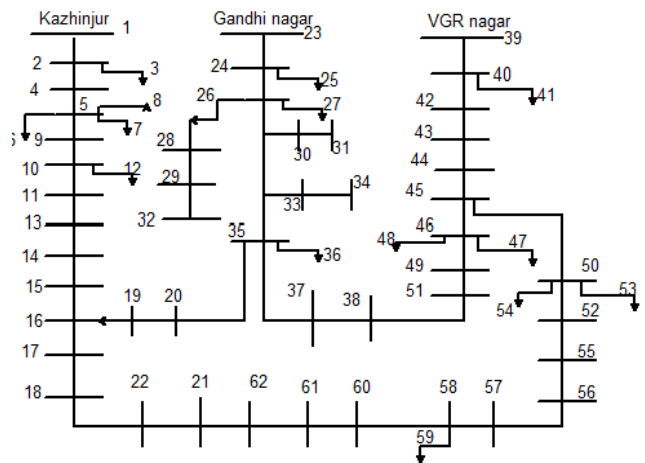

Fig. 8. Single line diagrams of three substations with 62 buses (before reconfiguration)

The Fig.8 shows a single line diagram of three substations with 62 buses in the substation and the loads are not in fully loaded condition. The substations having three outgoing feeders and sixty two numbers of distribution transformers are used to supply electricity and the station power factor is 0.95 lagging. The various load centers are Kazhinjur, Gandhi Nagar, V. G Rao Nagar and their installed capacity of loads are 3600 KVA, 4000 KVA and 5350 KVA. The connected loads for each feeder are not in full load condition, so the total power consumption of connected loads for three feeders are 13.5 MW. The load of this system receives a voltage of 440V and lamp load. The test system is taken for the research only for the part of 3 buses out of 12 buses in the distribution system.

Results of the IEEE 33 bus

Table. 3. Comparison of active power loss for various methods

S No	Method	P _{LOSS} (kW)	Switches (No)
1	EPO [16]	139.8 (29 node)	5
2	PSO [17]	31 %	5
3	ANN [18]	0.4 MW	5
4	SLO [19]	202	5
5	ABC [20]	375.01	5
6	GE [21]	466.5	4
7	ACB [22]	73 %	5

Table 3 shows the comparison of real power loss of IEEE 33 bus system for different methods of

optimization techniques... After implementing the optimization methods and VSI techniques in network reconfiguration process, there are only three sectionalized switches to achieve minimum loss when compared to earlier configuration which had fifteen switches. The procedure of the network reconfiguration for the three distribution systems are calculated based on the new VSI equations implemented in the two flowcharts and the related best results are tabulated. The minimum current flow is the best method for 62 bus systems in comparison to IEEE standards. The distributed forward backward sweep algorithm of load flow analysis of simulation results are given below. The comparison of real and reactive power losses before reconfiguration and after reconfiguration is given below.

Table 4. Before Reconfiguration (Indian system 62 bus)

S NO	Method	P _{LOSS}	Q _{LOSS}	Current/Voltages	Switches (No)
1	Min I	36.49 KW	16.14 KVAR	9.4988 A	15
2	Min V	34.87 KW	12.51 KVAR	9.87 KV	15

Table 5. After Reconfiguration (Indian system 62 bus)

S NO	Method	P _{LOSS}	Q _{LOSS}	Current/Voltages	Switches (No)
1	Min I	30.09 KW	13.78 KVAR	12.85 A	3
2	Min V	30.097 KW	13.067 KVAR	10.74 KV	3

Table 4 and 5 shows the real and reactive power loss of minimum current and the minimum voltage method before and after reconfiguration of 62 buses respectively. Indian systems on comparing with the IEEE 33 bus. The results are superior than the older reconfiguration. After the reconfiguration technique based on the new VSI, power losses are decreased such as active power losses from 36.64 KW to 30.06KW, Reactive power losses from 16.14KVAR to 13.78KVAR, voltages, angle of all the buses, power loss reduction keeping cost in mind the effectiveness. In this condition, all the operating bus voltages are dramatically increased from 10.04KV to 11KV. By comparing three methods, minimum branch current based reduction method is an excellent method because the bus voltages increase.

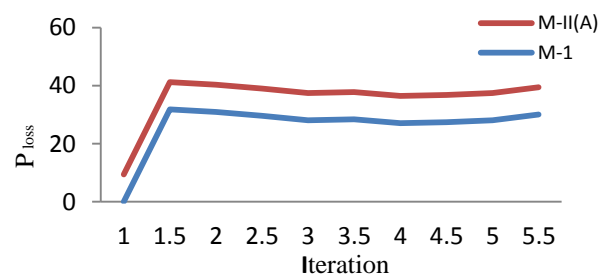

Fig. 9. Comparison of active power loss curves the 62 bus

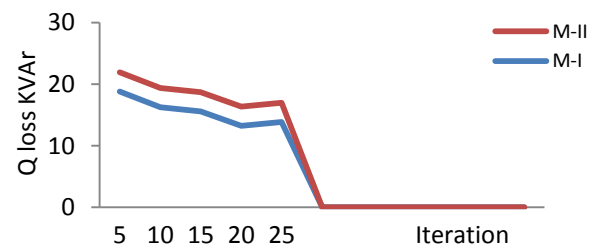

Fig. 10. Comparison of reactive power loss curves the 62 bus

Fig 9 and 10 are the active power losses and the reactive power losses versus no of iterations of before and after reconfigurations.

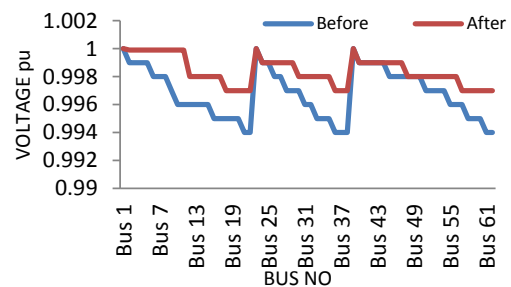

Fig. 11. Comparison of Bus voltages before and after reconfiguration 62 bus

Fig 9, 10 and 11 shows the before reconfiguration condition which is expressed in the blue color and the red color are indicate used to the losses and voltage profile of after reconfiguration based on the new VSI techniques in reconfiguration processes. The bus voltages have been improved from the before reconfiguration to the after reconfiguration of the given 62 bus system. The voltage profile and loss reduction in respective cases are compared subsequently. The voltage levels are increased from 9.9 KV to 10.87 KV at the tail end of the distribution systems after the reconfiguration. Moreover real and reactive losses have also reduced. The equivalent circuit of radial distribution system of after network configuration is given below.

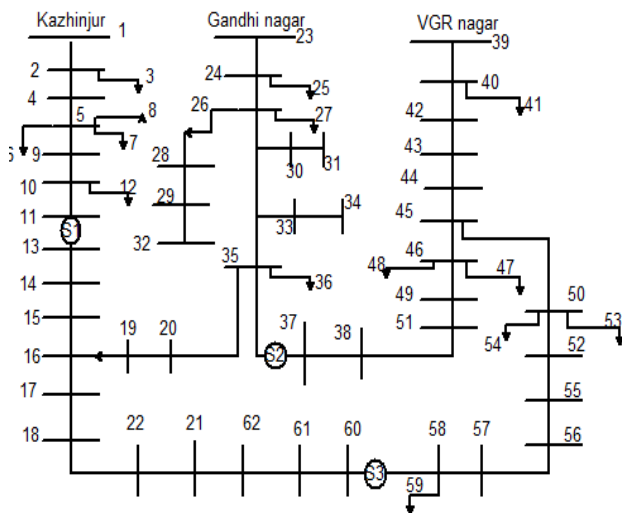

Fig.12. Single line diagrams of three substations with 62 buses (after reconfiguration)

Fig. 12. shows a single line diagram of three substations with 62 buses after reconfiguration. This is the best method of network reconfiguration method. Exhaustive technique is used to determine the optimal switching configuration and loss minimization to reconfigure the system based on the VSI equation. MATLAB software is used to find the load flow parameters of two methods to optimize switching schemes to minimize the losses. Based on the calculation results the power loss of the system 62 bus is about 36.48KW. With the network reconfiguration scheme, the power loss can be minimized from 36.489KW to 30.04KW. Therefore approximately 6KW can be saved by network reconfiguration for 62 bus radial distribution system. These energy saving is up to Rs 1.2 lakhs per year of Indian Economy. After network reconfiguration all operating bus voltages are hugely increased to 10.99KV. However, the aim of the research is reducing the real power loss, reactive power loss and thereby improving the voltage profile and optimizing the number of switches form the new VSI of all buses.

6. Conclusions

In this paper reported a novel voltage stability indicator is used for minimizing the losses in the distribution system. The proposed method is tested on IEEE 33 bus and an Indian system of 62 buses. The simulation result are presented and it can be seen from the result of the proposed technique, which offers better loss reduction, voltage profile improvement in the distribution systems for all the buses.

Reference

1. Ganghadhar K.A. – “Power system stability studies” – Khanna publishers, Delhi - 2005.
2. Prabha Kundhur – “Power system analysis, design,

- operation and control “, TMH publishers -2006 edition
3. Baron. M.E, Wu F.F, “Network reconfiguration in distribution system for loss reduction and load balancing index”, IEEE proceedins, vol. 132, .No.6, 1985, pp. 285-293.
4. Smail Musrin, Rah man. T.K.A., “On line stability based contingency ranking using Fast voltage stability Index ,IEEE explore 2002, PP. 1118-1123
5. Jain. T.,Srivasta. L “A Fast voltage contingency screening using RDS using NN”, IEEE transactions on power systems, Vol. 18, no. 4, November 2003.
6. Eminoglu. U., ”A voltage stability index for radial distribution network”, In procedeeding of the UPEC conference on 2007, vol.408, pp. 8-17.
7. Gubina. F., Strmenik. B. “A simple approach to voltage stability assessment in radial network”.IEEE Transaction a power system, vol.12, .No.3, Aug 1997, PP. 1121-1128.
8. Jong Rim, Shin. Y. Lee” A new optimal routing algorithm for less minimization a radial power system. IEEE Transaction and power system, vol.22, .No.2, May 2007, pp. 648-657.
9. Ramesh. L. “minimization of power loss in distribution systems by different techniques”, International journal of electrical and Electronics engineering, 2009,pp. 521-527.
10. Essay. Abdul “Network reconfiguration using PSAT for power loss reduction in distribution systems “, in proceeding of the International conference on energy, power and control, Basra, Iraq, November 30, 2010. pp. 62-66
11. Chakaravarthy. M., Das. D. ”voltage stability analysis of radial distribution network”, Electrical power and energy system. volume.23, pp-129-135-2001.
12. Pujara. A.V. “ Voltage stability index of radial distribution systems “ In Proceedings of ICETECT December 2011 pp 180 -185
13. Srinivasan. R. and Narashimman. S.,” A new algorithm for the network reconfiguration of distribution feeders for loss minimization “, IEEE transactions on power delivery, Vol 7, no 3, pp 1484-1491, 1992.
14. Vadivelu. KR, “Maximum loadability for weak bus identification using FVSI”, International journal of EEETC, January 2014, pp. 14-22.
15. Jayadeep, ”Network reconfiguration of distribution systems using fuzzy controlled Evolutionary programing”, International journal of Engineering and science & advanced technology, Vol 2, no 2, pp 176-186, April 2012.
16. Tamer M Khalil, “Reconfiguration for loss reduction of distributed systems using SPSO, International journal of multidisciplinary sciences and engineering”, Vol 3, no 6 June 2012.
17. Partha kayaln, “ANN based network reconfiguration approach for voltage stability improvement of distribution network”, IEEE 2011.