

# TO ENHANCE AND DESIGN IMPEDANCE OF ACTIVE FILTERS BY PQ AND SDM - SAPF WITH $I_d - I_q$ TECHNIQUES

**B.Kiruthiga<sup>1</sup> (corresponding author)**

Assistant Professor, Department of EEE, Velammal College of Engineering and Technology,  
Madurai

**bki@vcet.ac.in**

**Dr.R. Narmatha Banu<sup>2</sup>**

Professor, Department of EEE, Velammal College Engineering and Technology, Madurai  
buvanriya@gmail.com

**Dr.D.Devaraj<sup>3</sup>**

Professor & Dean, Kalasalingam Academy of Research and Education, Krishnan Kovil

**Abstract:** – In recent trends, the nonlinear loads are most popular which is used by commercial, residential consumers and industrial purpose. Quality of power is to be delivered due to rapid rise in the usage of harmonics producing nonlinear loads which has included adjustable speed drivers, electronics converters, power suppliers with switched mode and arc furnaces. The quality is to be used to express the purity in the voltage and current waveforms. There are various methods are followed to decrease harmonics in the electric power transmission network which includes the help of line reactors, transformer isolation, phase shifting transformers and active power filter. The SAPF is the shunt active power filter which is the power electronics converter which helps to inject current having same amplitude and opposite phase with the original harmonics current. In this paper, proposed to enhance and design impedance of active filters by p – q theory and SDM – SAPF (synchronous detection method – shunt active power filter) with  $I_d - I_q$  techniques has been proposed. The p – q theory helps to exploit the symmetrical accelerate the evaluations for active filters controllers. The SDM – SAPF is the synchronous detection method in shunt active power filter helps to digital control based on instantaneous power theory. The  $I_d - I_q$  method helps to extract the reference currents of unbalance shunt active filters, balance shunt active filters and sinusoidal shunt active filters. This control technique is to be converged to the same compensation characteristics. The simulation result shows that there is the analysis of harmonics suppression by comparing various designing methodology.

**Keywords** - Active filters, harmonics suppression, shunt active power filter, p – q theory, SDM – SAPF,  $I_d - I_q$  method

## 1. Introduction

An active filter is a type of analog circuit implementing an electronic filter using active components, typically an amplifier. Amplifiers included in a filter design can be used to improve the cost, performance and predictability of a filter. An amplifier prevents the load impedance of the following stage from affecting the characteristics of the filter. An active filter can have complex poles and zeros without using a bulky or expensive inductor. The shape of the response, the Q (quality factor), and the tuned frequency can often be set with inexpensive variable resistors. In some active filter circuits, one parameter can be adjusted without affecting the others. An active filter is the one form of the analog circuit which is to implement an electronic filter with the help of the active components. This is also known as an amplifier because the amplifiers are integrating in a filter design which helps to increase the cost, performance and predictability. In this filter, the amplifier helps to prevent the load impedance of various stages which are affecting the filter characteristics. The figure.1 shows the basic diagram of the active filter.

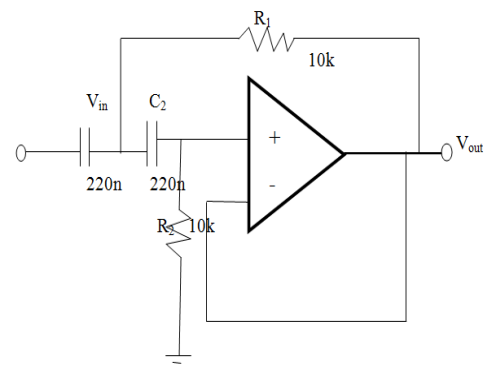

Figure.1 Basic Diagram of Active Filter

### 1.1 shunt active power filter

The shunt active power filter is a self controlled dc bus which has the design topology structure similar to that of the static compensator. This is used for reactive power compensation in power transmitting systems. There are various design parameters are to be used in this shunt active filter such as power circuit, control circuit, control strategies, and ripple filters. This filter helps to compensate load current harmonics with the help of injecting equal but the harmonic current compensation is presenting an opposite. In that time, this filter performs as a current source which is injecting the harmonic components which are to be generated with the help of load but the phase is shifted by  $180^\circ$ . The figure.2 shows the block diagram of a shunt active power filter.

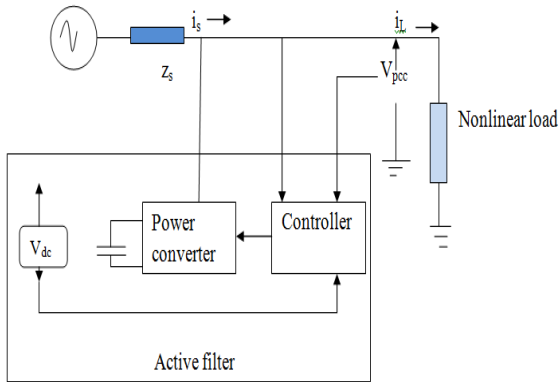

Figure.2 Block Diagram of Shunt Active Power Filter

### 1.2 Harmonics suppression

There are various non linear loads are to be presented such as industrial and domestic devices, power level inverters and office equipments which are to be generated harmonic currents. This current will be spreaded into the electric grid. The current harmonic is passed to the transformers or grid which gives the results in voltage harmonics in the particular feeders. This is called as conductor impedance which increases with frequencies of the currents which is passed through with different impedance. This is to appear for the each range of the current harmonics. These harmonic current of range will be created through the impedance with related harmonic voltage. When all loads are to be connected to the particular point which is too fed with the same perturbed voltage. The figure.3 shows the block diagram of harmonic suppression.

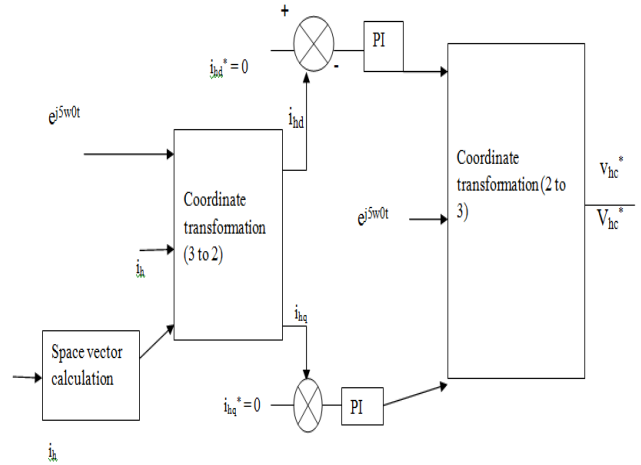

Figure.3 Block Diagram of Harmonic Suppression

### 2. Related works

**Dhiraj N. Katole [1] et al** proposed a modified instantaneous  $p - q$  theory for single phase DVR for mitigation of voltage sag in case of nonlinear load. This controller helps to control the single phase DVR with effective manner. This concept is based on the correction of load voltage without any change in phase. The modified controller is depends on the proportional integral gains to mitigate single phase voltage sag. The performance analysis helps to indicate the proposed controller which can restore single phase voltage sag effectively. The paper has the following information such as instantaneous  $p - q$  theory on single phase, proposed instantaneous  $p - q$  theory, reference injected voltage generation, and performance analysis. **Sachin Devassy [2] et al** proposed a modified  $p - q$  theory based control of solar PV integrated UPQC - S. The FFPS fundamental frequency positive sequence voltages are to be extracted which is helps to generalize with cascaded delay signal cancellation. This method is to be used in  $p - q$  theory which is based on control that is generating reference grid currents for shunt compensator. The performance will be analyzed with dynamic manner which is to be verified with linear and nonlinear load. This paper has following information such as configuration of PV - UPQC - S, control of PV - UPQC - S, generalized cascaded delay signal cancellation block, load power calculation block, shunt VSC control structure, control of series VSC, reference signal generation, PV - U PQC - S behavior during irradiation change, PV - UPQC - S performance during grid voltage disturbances and performance analysis. **Mohammad Hosein Alaei [3] et al** proposed an improved performance of single phase

shunt active power filter by using conservative power theory and model predictive control. A single phase power system is to be analyzed based on the pure sinusoidal voltage source and non linear load. The reference currents are to be obtained from the filter with the help of the conservative power theory and model predictive control switching algorithm. This algorithm is to be applied in the conventional with two level inverters. This paper has the following information such as proposed control approach for single phase shunt active power filter, hysteresis switching algorithm, MPC switching algorithm, and performance analysis.

**Sabir Ouchen [4] et al** proposed a dynamic performance improvement of three phase shunt active power filter using predictive direct power control. The major role of this method is to compensate the undesirable harmonics which is to be presented in the source current and to reject power by high transient dynamics. This control algorithm is to be proposed with effective manner based on the elimination of harmonics, increasing the effectiveness of power quality and reactive power. This paper has following information such as synoptic description of the system, DC bus control, predictive direct power control strategy, and performance analysis. The further development of this paper is to develop the novelty like grid currents which is to be presented in the sinusoidal shape based on tolerable THD. **Akash V. Barva [5] et al** proposed a design and simulation of four – leg based three phase four – wire shunt active power filter. The three phases electrical distribution system is widely used which is to deliver the power to the single phase and three phase loads. This method causes harmonics, reactive power burden, and currents of unbalanced circuits and excessive neutral current. This issue will be mitigated with four wire shunt active power filter which is used in 3P system. This paper has following information such as control algorithm, instantaneous reactive power theory, synchronous reference frame theory, design of shunt active power filter, and performance analysis. **Harsha Vanjani [6] et al** proposed a Takagi – Sugeno (TS) type fuzzy logic controller for three phase four wire shunt active power filter for unbalanced load. This paper gives the various comparisons of mamdani and TS type fuzzy logic controller which helps to control three phase shunt active power filter. The fuzzy method helps to tune the PID controller to autotune controller. The reactive power theory is to be implemented which helps to generate reference currents. This paper has following

information such as instantaneous reactive power theory, PI and PID controller, fuzzy logic controller for SAPF, and performance analysis. **Sarita Samal [7] et al** proposed harmonics mitigation by using shunt active power filter under different load condition. The harmonics compensation produces the large resonance problems and it produces the effect of the source impedance on the performance effects. This paper has the following information such as system configuration, synchronous reference frame theory, control scheme of shunt active power filter, design of hysteresis controller, simulink model of the shunt APF, and performance analysis.

**Li Lanfang [8] et al** proposed a repetitive control implementation with frequency adaptive algorithm for shunt active power filter. This method helps to track the periodic signal with variable grid frequency and the variable delay items are caused by the time varying grid frequency which is to be closely related with pade approximants. This proposed scheme is to be developed based on stability criterion. The paper has the following information such as proposed repetitive control scheme with frequency adaptive capability, repetitive control system with frequency adaptive for three phase shunt APF, and performance analysis. The simulation and result gives the details about repetitive control scheme which is an effective solution to improve the tracking performance and decreased the harmonic distortion. **Balaga UdayaSri [9] et al** proposed an improvement of power quality using PQ – theory shunt active power filter. It deals with estimation of the three phase shunt APFS for power quality improvement. The three phase shunt active filter is to be developed based on the modelling with mathematical of the system which can be observed the improvement in the source current in the norms of total harmonic distortion of source current. The paper has the following information such as shunt active power system design, instantaneous PQ theory, instantaneous space vectors on the alpha – beta coordinates estimation of compensation currents, DC capacitor voltage control circuit, and capacitor of the dc capacitor, control scheme of shunt active filter, PI controller, hysteresis controller, and performance analysis.

**Jitendra Tandekar [10] et al** proposed a real time implementation of multilevel converter based shunt active power filter for harmonic compensation in distribution system. This technique helps to increase the power quality with the help of the seven levels cascaded multilevel converters depends on the shunt

active power filter. This system helps to reduce the weight and cost of the system. The simulation and results are to be analyzed with the help of the tool like MATLAB / simulink with charge balancing alternate phase opposition disposition – pulse width modulation is to be used. This paper has the following information such as CHB multilevel converter and description ASE of use, and performance analysis.

### 3. Problem definition

Harmonics increase the amount of power required by the system due to reduction in power quality, contributing to a lower power factor and higher energy costs as a result of the reduced efficiency of the system. Harmonic filtering acts to filter out the electrical harmonics in a system. so there is a need of suppression of harmonics.

### 4. Proposed design

In the proposed work to enhance and design impedance of active filters by p – q theory and SDM – SAPF (Synchronous Detection Method – Shunt Power Active filter) with  $I_d - I_q$  techniques. The p – q theory helps to exploit the symmetrical accelerate the evaluations for active filters controllers. The SDM – SAPF is the synchronous detection method in shunt active power filter helps to digital control based on instantaneous power theory. The  $I_d - I_q$  method helps to extract the reference currents of unbalance shunt active filters, balance shunt active filters and sinusoidal shunt active filters. This control technique is to be converged to the same compensation characteristics.

#### 4.1 Shunt active power filter

The shunt active power filter helps to compensate the load current harmonics with the help of injecting equal but opposite harmonic compensating current. The figure.4 shows that there is the analysis of shunt active power filter.

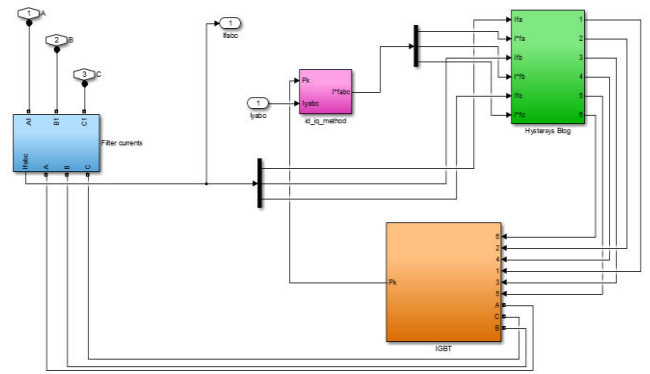

Figure.4 Diagram of SAPF

#### 4.2 p – q Theory

The p – q theory is depends on the  $\alpha\beta 0$  transformation which is also known as Clarke transformation. This method consists in a real matrix to transform three phase voltages and currents to the  $\alpha\beta 0$  reference frame which is given by equation 1 and 2 as follows,

$$\begin{bmatrix} Vec \\ Vec_\alpha \\ Vec_\beta \end{bmatrix} = \sqrt{\frac{2}{3}} \begin{bmatrix} \frac{1}{\sqrt{2}} & \frac{1}{\sqrt{2}} & \frac{1}{\sqrt{2}} \\ 1 & \frac{-1}{\sqrt{2}} & \frac{-1}{\sqrt{2}} \\ 0 & \frac{\sqrt{3}}{2} & \frac{-\sqrt{3}}{2} \end{bmatrix} \begin{bmatrix} Vec_p \\ Vec_q \\ Vec_r \end{bmatrix} \text{-----(1)}$$

The inverse transform is given by,

$$\begin{bmatrix} Vec \\ Vec_\alpha \\ Vec_\beta \end{bmatrix} = \sqrt{\frac{2}{3}} \begin{bmatrix} \frac{1}{\sqrt{2}} & 1 & 0 \\ \frac{1}{\sqrt{2}} & \frac{-1}{2} & \frac{\sqrt{3}}{2} \\ \frac{1}{\sqrt{2}} & \frac{-1}{2} & \frac{-\sqrt{3}}{2} \end{bmatrix} \begin{bmatrix} Vec_p \\ Vec_q \\ Vec_r \end{bmatrix} \text{-----(2)}$$

The three phase currents are to be denoted as ( $I_p, I_q, I_r$ ) present in the generic instantaneous which can be transformed to the axis of  $\alpha\beta 0$ .

The main advantage of the  $\alpha\beta 0$  transformation is the splitting of zero sequence components to the zero sequence axis. The  $\alpha$  and  $\beta$  axis does not have contribution from zero sequence components. When the three phase system has only three wires that is no neutral conductor and no zero sequence current equipments which are to be presented and  $I_0$  is to be rejected from the equation no 2. The real and imaginary powers are to be calculated is given by equation 3 as follows,

$$\begin{bmatrix} p \\ q \end{bmatrix} = \begin{bmatrix} Vec_\alpha & Vec_\beta \\ Vec_\beta & -Vec_\alpha \end{bmatrix} \begin{bmatrix} I_\alpha \\ I_\beta \end{bmatrix} \text{-----(3)}$$

Here the p is the real power , the total energy flow per unit time present in the three wire three phase

system which has the components like  $\alpha\beta$  and  $q$  is the imaginary power and it has the nontraditional physical synonym. It helps to measure the quantity of power or current which flows through each phase without transporting energy at particular instant. The algorithm shows that there is the analysis of  $p - q$  theory for active power filter.

**Algorithm**

- Step.1 Measure load current and voltage.
- Step.2 Apply the Clarke transformation process.
- Step.3 Estimate the  $p$  and  $q$  value with the help of equation 3.
- Step.4 Filtering the calculation value of  $p$  and  $q$  after completion of the step3 estimation.
- Step.5 Evaluate the compensation currents.
- Step.6 Apply Clarke inverse transform is to be applied with the help of above equations.

**4.3  $I_d - I_q$  METHOD**

The load current is to be represented as  $I_{load\_m}$ ,  $I_{load\_n}$  and  $I_{load\_o}$  which are to be tracked upon the park's transformation is to be operated which is to obtain related  $d - q$  axes currents  $I_{load\_d}$ ,  $I_{load\_q}$  which is mathematically defined in equation.4.

$$\begin{bmatrix} I_{load\_d} \\ I_{load\_q} \end{bmatrix} = \begin{bmatrix} I_{load\_dlh} & + I_{load\_dnh} \\ I_{load\_qlh} & + I_{load\_qnh} \end{bmatrix} \text{-----(4)}$$

$$\begin{bmatrix} I_{load\_d} \\ I_{load\_q} \end{bmatrix} = \begin{bmatrix} \sin wt & \cos wt \\ -\cos wt & -\sin wt \end{bmatrix} \begin{bmatrix} 1 & \frac{-1}{2} & \frac{-1}{2} \\ 0 & \frac{\sqrt{3}}{2} & \frac{-\sqrt{3}}{2} \end{bmatrix} \text{-----(5)}$$

Here,  $w$  is the rotational speed of synchronously rotating frame of  $d - q$ . Based on the  $i_d - i_q$  control strategy the average value of the  $d -$  axis component of load current is drawn from supply.  $I_{load\_dlh}$ ,  $I_{load\_qlh}$  denotes the fundamental frequency component of the load current with  $d - q$  frame. The oscillating equipments are denoted as  $I_{load\_dnh}$  and  $I_{load\_qnh}$  which are filtered out with the help of the low pass filter. The figure.5 shows that there is the simulation analysis of  $i_d - i_q$  method.

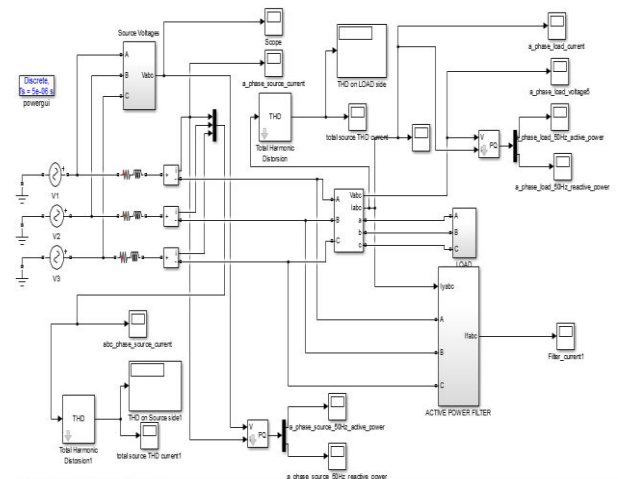

Figure.5 Simulation Analysis of  $i_d - i_q$  Method

**4.4 HARMONIC SUPPRESSION**

There are various numbers of ways which may execute the attractiveness of the reactive harmonic suppressors.

- The harmonic filters are used for better matched to properties of the distributed system. These are installed to the available filters. The designing of the matched filters is used for optimization procedures.
- The optimization process helps to perform the effective devices for harmonic suppression only up to predicted level of the current and voltage minor harmonics. The harmonics levels are differentiated for the purpose of distribution of voltage and the load current.
- The customers of power should be notices and resonant harmonic filter is taken off a shelf cannot be effective devices for the harmonic suppression. The main information is enabled after completion of installation process. The filter is selected based on the filter information.

The harmonic suppression system is used for various applications to mitigate the harmonic currents present in the distribution system. This system consists of a parallel capacitive or inductive or resistive network which is tuned to the next level of the harmonic to fundamental frequency of 180 Hz. The electrical characteristics of the system has the high resistance to the flow of high level harmonic current and very low resistance to the flow the fundamental 60 Hz current. The figure.6 shows that there is the analysis of the harmonic suppression power detector technique.

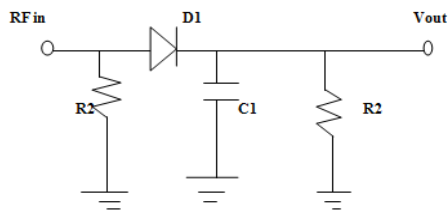

Figure.6 Harmonic suppression power detector technique

#### 4.5 SDM – SAPF (SYNCHRONOUS DETECTION METHOD – SHUNT ACTIVE POWER FILTER)

The synchronous detection method is assumed that there are three phase main currents are balanced after compensation. It helps to evaluate the amplitude of the main currents. The load currents are denoted with nonlinear manner such as  $I_1(t)$ ,  $I_2(t)$ ,  $I_3(t)$  and related phase voltage  $vol_1(t)$ ,  $vol_2(t)$ , and  $vol_3(t)$  which are measured from the various lines and the real power is to be evaluated  $P(t)$  is determined which is denoted below.

$$Power(t) = [vol_1(t) vol_2(t) vol_3(t)] * [I_1(t) I_2(t) I_3(t)] \text{ -----(6)}$$

The average measurement value of  $Power_{dc}$  is to be determined with the help of applying  $Power(t)$  to a low pass filter. The real power is dividing to the three phases,

$$Power_1 = (Power_{dc} vol_{1m}) / (vol_{1m} + vol_{2m} + vol_{3m}) \text{ -----(7)}$$

$$Power_2 = (Power_{dc} vol_{2m}) / (vol_{1m} + vol_{2m} + vol_{3m}) \text{ -----(8)}$$

$$Power_3 = (Power_{dc} vol_{3m}) / (vol_{1m} + vol_{2m} + vol_{3m}) \text{ -----(9)}$$

Where,  $vol_{1m}$ ,  $vol_{2m}$  and  $vol_{3m}$  are the amplitudes of  $vol_1(t)$ ,  $vol_2(t)$  and  $vol_3(t)$  respectively. The balanced line currents will be estimated,

$$I_{s1} = (2 vol_1 Power_1) / vol_{1m}^2 \text{ ----- (10)}$$

$$I_{s2} = (2 vol_2 Power_2) / vol_{2m}^2 \text{ ----- (11)}$$

$$I_{s3} = (2 vol_3 Power_3) / vol_{3m}^2 \text{ ----- (12)}$$

The compensation current references are denoting following below,

$$I_{c1}^* = I_{s1} - I_1 \text{ ----- (13)}$$

$$I_{c2}^* = I_{s2} - I_2 \text{ ----- (14)}$$

$$I_{c3}^* = I_{s3} - I_3 \text{ ----- (16)}$$

These compensation current references are too fed the VSI and it supplies the particular replica of those elements. This is to be modeled as a current amplifier with unity gain.

The figure.7 shows that there is the analysis of synchronous detection method with SAPF and the filters controllers. Analysis of three phase power system without filter is shown in figure 8.

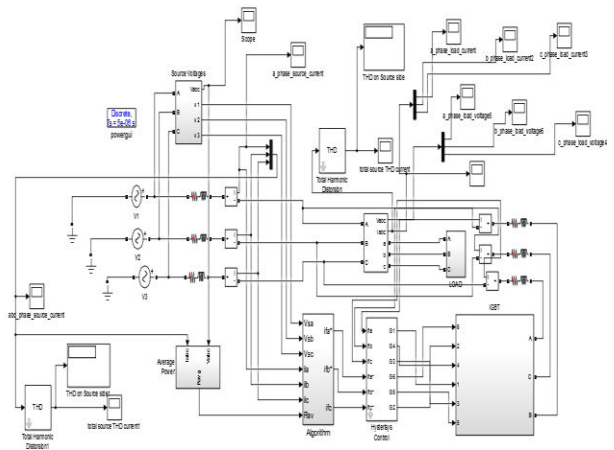

Figure.7 Simulation Analysis of SDM – SAPF Method

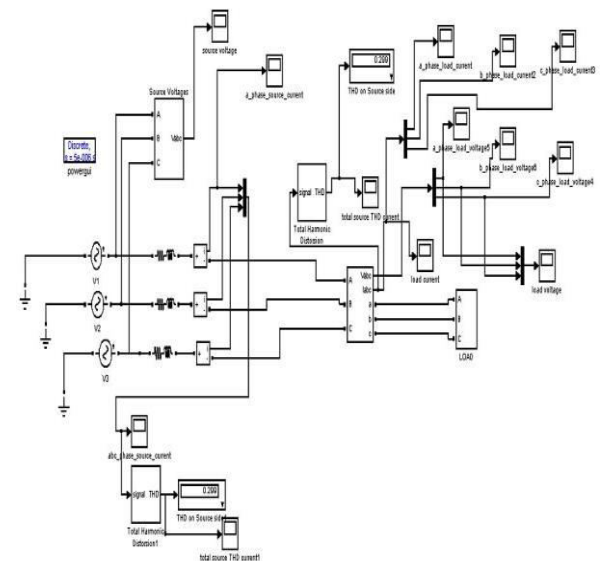

Figure.8 Three Phase Power System without Filter in MATLAB

#### 5 Performance comparison

In this work, improving the impedance of active filters by p – q theory and SDM – SAPF (synchronous detection method – shunt active Power filter) with  $I_d - I_q$  techniques proposed and the p – q



theory helps to exploit the symmetrical accelerate the evaluations for active filters controllers. The source voltage is the two terminal devices that are sustain the predicted voltage. The voltage source is to maintain with ideal manner which is independent of the load resistance. The source current is the dual or voltage sources which are fed from a negative voltage supply. The figure.9and figure.10 denotes the wave form of source voltage and source current. Table 1 represents THD Excluding and including Filter action.

**Table: 1 THD Excluding and Including Filter action**

| Parameters          | $I_d-I_q$ | SAPF   |
|---------------------|-----------|--------|
| THD(Without Filter) | 30.42%    | 30.42% |
| THD(With Filter)    | 1.78%     | 1.21%  |

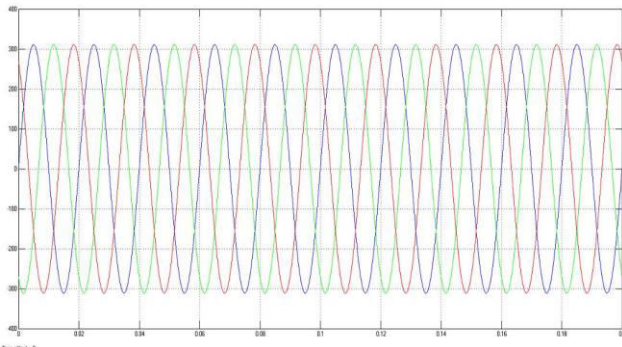

Figure.9 Source Voltage

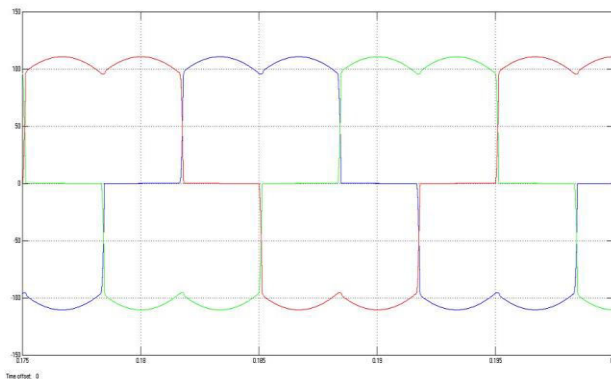

Figure.10 Source Current

### 5.1THD analysis

The (THD) total harmonic distortion is the determination of the harmonic distortion which is presenting in a signal. It is defined as the ratio of the addition of the powers of the harmonic components to the powers of the fundamental frequency. The Figure 11 shows that FFT analysis of without Filter Method.

Figure 12 represents the FFT Analysis of  $I_d-I_q$  Method, where frequency is 50Hz .FFT Analysis of SAPF Method is concluded and represented shown in figure 13, Output Pulses Generated from Hysteresis Controller and Graphical Representation of Power factor represented as a figure 14 and figure 15 respectively.

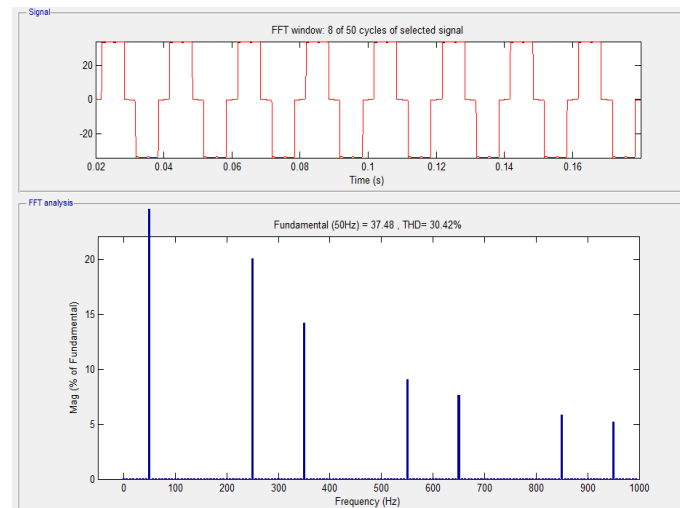

Figure.11 FFT Analysis of without Filter

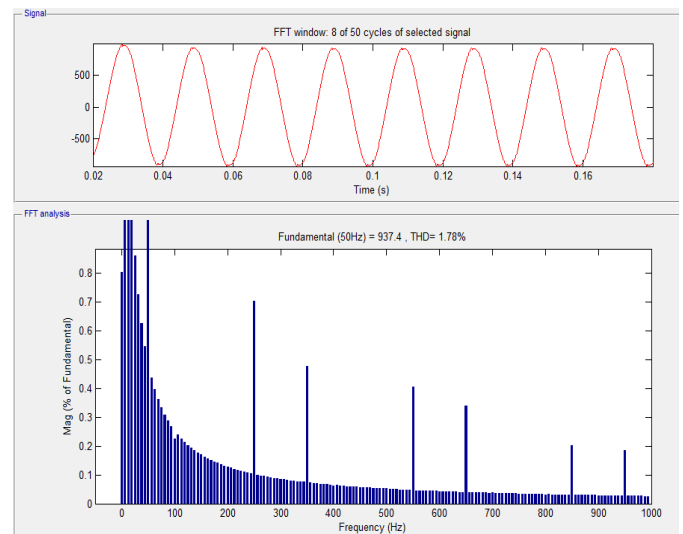

Figure.12 FFT Analysis of  $I_d-I_q$  Method (with filter)

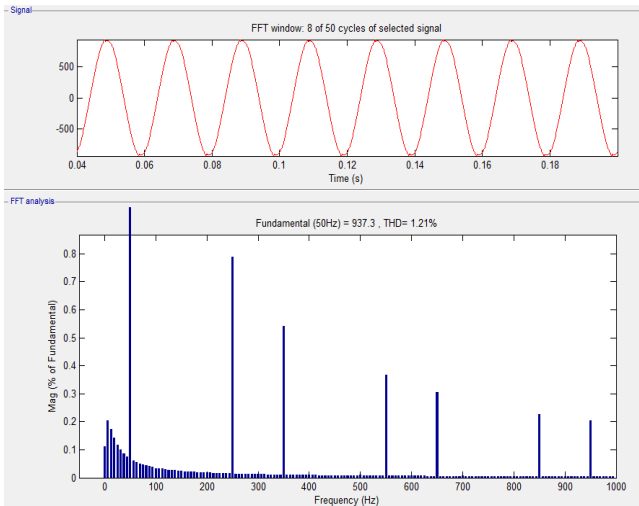

Figure : 13 FFT Analysis Of SAPF Method (with filter)

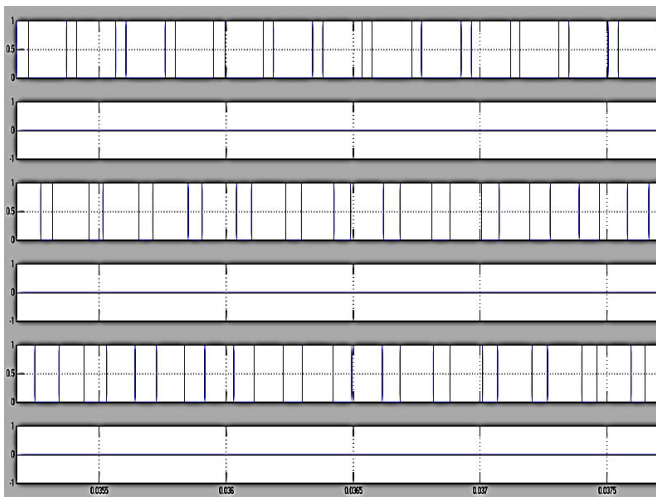

Figure 14 : Output Pulses Generated From Hysteresis Controller

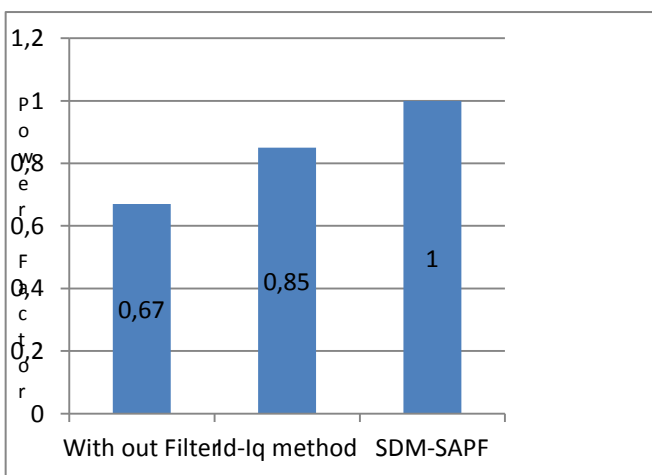

Figure 15: Graphical Representation of Power factor

## 6. Conclusion

The SDM – SAPF is the synchronous detection method in shunt active power filter helps to digital control based on instantaneous power theory and THD Value is 1.78%. The  $I_d - I_q$  method helps to extract the reference currents of unbalance shunt active filters, balance shunt active filters and sinusoidal shunt active filters and THD value is 1.21%. The simulation and results give the information about SDM – SAPF is better than  $I_d - I_q$  method and also variation occurs in the wave form when the THD fundamental frequency levels are to be varied such as 37.82, 38.91 and 28.66.

## 7.References:

- [1] Dhiraj N. Katole, M. B. Daigavane, S. P. Gawande, Prema Daigavane, “**Modified instantaneous p-q theory for single phase DVR for mitigation of voltage sag in case of nonlinear load**”, IEEE, 978-1-5090-2476-6, 2016.
- [2] Sachin Devassy, Bhim Singh, “**Modified p-q Theory Based Control of Solar PV Integrated UPQC-S**”, IEEE, 978-1-4799-8397-1/16, 2016.
- [3] Mohammad Hosein Alaee, Seyed Abbas Taher, and Zahra Dehghani Arani, “**Improved Performance of Single-Phase Shunt Active Power Filter by Using Conservative Power Theory and Model Predictive Control**”, IEEE, 978-1-5386-4699-1/18, 2018.
- [4] Sabir Ouchen, Heinrich Steinhart, “**Dynamic Performance Improvement of Three Phase Shunt Active Power Filter using Predictive Direct Power Control**”, IEEE, 978 - 9 - 0758 - 1528 - 3, 2016.
- [5] Akash V. Barva and Priyank R. Bhavsar, “**Design and Simulation of Four-Leg Based Three Phase Four-Wire Shunt Active Power Filter**”, IEEE, 978-1-5386-2051-9/18, 2018.
- [6] Harsha Vanjani, U. K. Choudhury, Meha Sharma, Bhavesh Vanjani, “**Takagi-Sugeno (TS)-Type Fuzzy Logic Controller for Three-Phase Four-Wire Shunt Active Power Filter for Unbalanced Load**”, IEEE, 1 978-1-4673-8962-4/16, 2016.
- [7] Sarita Samal, Prakash Kumar Hota, Prasanta Kumar Barik, “**Harmonics Mitigation by using Shunt Active Power Filter under Different Load Condition**”, IEEE, 978-1-5090-4620-1/16, 2016.
- [8] Li Lanfang, Chen Xiaoke, Ma Hui, Sun Biaoguang, Xu Xiaogang, Xie Yunxiang, “**Repetitive Control implementation with Frequency Adaptive algorithm for Shunt Active Power Filter**”, IEEE, 978-1-5090-1210-7/16, 2016.



- [9] Balaga UdayaSri, P.A.Mohan Rao, Dasumanta Kumar Mohanta, M. Pradeep Chandra Varma, **“Improvement of power quality using PQ-theory shunt-active power filter”**, IEEE, 978-1-5090-4620-1/16, 2016.
- [10] Jitendra Tandekar, Amit Ojha, Shailendra Jain, **“Real Time Implementation of Multilevel Converter based Shunt Active Power Filter for Harmonic Compensation in Distribution System”**, IEEE, 978-1-5090-4530-3/16, 2016.
- [11] A.Krama, L.Zellouma, B. Rabhi, **“Improved Control of Shunt Active Power Filter Connected to a Photovoltaic System Using Technique of Direct Power Control”**, IEEE, 978-0-9567157-6-0, 2016.
- [12] Shivansh Srivastava, Yash Shah, Bhavin Shah, Pratik Salvi and Rakesh M. Patel, **“Implementation and Simulation of Single Phase Active Shunt Power Filter”**, IEEE, 978-1-4673-8587-9/16, 2016.
- [13] A. Cleary-Balderas, A. Medina-Rios, O. Cruz-Hernández, **“Hybrid Active Power Filter Based on the IRP Theory for Harmonic Current Mitigation”**, IEEE, 978-1-5090-3794-0/16, 2016.
- [14] Yong Xu, Jiaqi Yu, Yijia Cao, Jingrong Yu, Ying Gu, **“State Variable Feedback Predictive Control Design for Single Phase Shunt Active Power Filter”**, IEEE, 978-1-5090-1210-7/16, 2016.
- [15] J Femila Roseline, Nikhil Kumar Sahoo, **“Implementation of Fuzzy Logic in shunt Active Power Filter for Renewable Power Generation System”**, IEEE, 978-1-5090-1706-5/16, 2016.
- [16] Ravinder Kumar, Pradyumn Chaturvedi, Hari Om Bansal and Pawan K. Ajmera, **“Adaptive Artificial Neural Network Based Control Strategy for Shunt Active Power Filter”**, IEEE, 978-1-5090-2476-6/16, 2016.
- [17] Jose Rubens Macedo Jr, Alexander E. Emanuel and John A. Orr, **“An Evaluation of Shunt Active Filtering Techniques in the Era of Smart Grids”**, IEEE, 978-1-5090-3792-6/16, 2016.
- [18] M.Yu. Artemenko, L.M. Batrak, S.Y. Polishchuk, V.M. Mykhalskyi, I.A. Shapoval, **“Reactive Compensation of Non-Active Power in Hybrid Shunt Filter of Three-Phase Four-Wire System at Random Load”**, IEEE, 978-1-5090-1769-0/16, 2016.
- [19] Shivam Singh Rajput, Sumita Chakraborty, Dr. Naimesh Zaveri, **“Study of Shunt Active filter using MATLAB Tools environment”**, IEEE, 978-1-4673-9745-2, 2016.
- [20] Tuçe Demirdelen, Rahmi Iker Kayaalp and Mehmet Tümay, **“Performance Investigation of High Level Modular Multilevel Inverter based Shunt Hybrid Active Power Filter”**, IEEE, 978-1-4673-9575-5/16, 2016.