

# ON THE MODELING OF CABLES ROBOT IN UNDER-ACTUATED MODE WITH AN EXTENSION TO FEEDBACK CONTROL

Assem THABET

Laboratoire de Recherche MACS (LR 16ES22), Université de Gabès, Tunisia  
Street Omar Ibn Khattab, Zrig - 6029, Gabes, +21675392100, [assem.thabet@yahoo.fr](mailto:assem.thabet@yahoo.fr)

**Abstract:** This paper proposes a design of a robust and a simplified dynamic model for a class of cables robots in an under-actuated mode. The objective is to use the under-actuated mode to provide a robust dynamic model which is derived from geometric and Kinematic equations. The analysis of the system is ensured under severe constraints on the cables robot. An extension to control, based on an observer by comparing two methods, is given when the observer is designed independently of the controller. The two observers are the EKE and the SODTSM Observer. High performances are shown through numerical simulation.

**Key words:** Cables Robots Model, Under-Actuated Mode, Geometric/Kinematic Equations, Extended Kalman Estimator, Feedback Control.

## 1. Introduction

In automated systems, particularly on production lines, robot manipulators are often used to facilitate assembly procedures to improve the quality of the assembled product [1] and to increase the quantity produced by reducing assembly time. Their use, however, is not only limited to this type of activity but also extends to various other fields such as military, medical [2] and others.

In recent years, a special class of parallel robots in which the rigid links are replaced by flexible links that are obtained thanks to the use of cables, have been studied. The effectors, terminal of the latter, each connects to the base by a number of active cables, the lengths of which make it possible to control the desired position and the orientation of this latter. This structure offers us several advantages compared to that of the classical robots [3]. Indeed, the use of cables facilitates the work on robots of high speed such as those presented by the work of [4] where the speed was of 13 m.s<sup>-1</sup> (all with observing the stability conditions and absence of the vibrations of the system). In the field of parallel robots, much of research tasks are published on the dynamics and the aspects of control of the latter [5-6]

However, in comparison with the great quantity of published works on the modelling of the classical robots, some articles were published on the control and state estimation of cable robots: approaches based on

robust regulators PID [7], approach based on Lyapunov stability [8] and the genetic algorithms to generate a fuzzy PID [9]. However, an important part of recent works focuses on the state estimation to supervise and control these types of nonlinear systems [10-11-12-15] which exist in the literature. The use of observers can already guarantee fault detection, isolation and estimation [13].

But the disadvantages of these approaches are related mostly to two considerations:

- \* The consideration of the global model [5-6-22] with an extensive number of variables and parameters, which make the stability and the real time implementation very difficult (taking into account the computation time, the sampling time ...).

- \* The use of control sequence structure which contains too many parameters [23] to be searched / or are dedicated to a typical example (robots with elastic or rigid cables, with or without disturbance ...) [24-25] / or based on the exact knowledge of all the states of the model [7-8]

These limitations motivate the design of a simplified dynamic model in an under-actuated mode with a very simple strategy for observer based feedback control. This paper proposes a simple and effective model in under-actuated mode to reduce the complexity of the full model and to avoid later the large number of actuators / sensors based on work of [21]. This also allows reducing the control sequence. The control will be generated based on an observer while guaranteeing a desired vector position. Two observers will be later applied on the model found, in the comparison purpose based on the work of [14] and [16].

This work is organized as follows. In Section 2, we will state the problem and present the preliminary. Next, in Section 3, we will give in details the steps of modeling the cables robot in under-actuated mode. Section 4 is dedicated to an extension to the state estimation (using the EKF) and the feedback control condition. Section 5 is devoted to the well-known performance of the proposed approach through a (validation of the proposed model and the feedback control) numerical simulation with a comparative study.

## 2. Problem Formulation

The cables robot considered in this paper is presented in Fig.1.

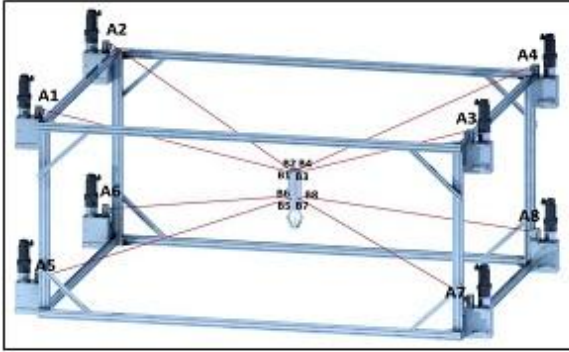

Fig.1. Cables Robot with 8 motors.

This kind of robot is known for its high speed and high precision in order to record biological signals of the insects by moving the electrophysiology device to stay closer to the insect. For this robot, the cables connecting the base fixes at the mobile platform (effectors) are used as transmission resource. The coordinated control lengths and/or tensions in the cables make it possible to move and apply efforts to the level of the effectors. The modelling of the robot then consists in making a geometrical, kinematic and dynamic analysis by the adaptation of a mathematical tool of the behaviour of the robot [17-18-19-22-23-25]. As shown in figure 1, the robot considered in this work is composed of eight cables connecting a base, a parallelepiped form provided with eight engines and with mobile effectors with six degrees of freedom. The geometrical problem consists in determining the lengths of the cables (vector with eight elements) starting from the vector with six elements describing the position and the orientation of the effectors. The engines allow to roll up cables and thus to control the position of the mobile effectors [17-21].

In order to reduce the number of parameters and variables of the robot while guaranteeing the same sequences of operations, we have to reduce the number of actuators (motors). This is feasible with an under-actuated mode. To do so, we reduce the number of motors: only 4 instead of 8. The reason for the choice of which engine must be considered, is the motor that is at the intersection of each three axis of a plane. Then, the considered robot becomes as given in Fig.2.

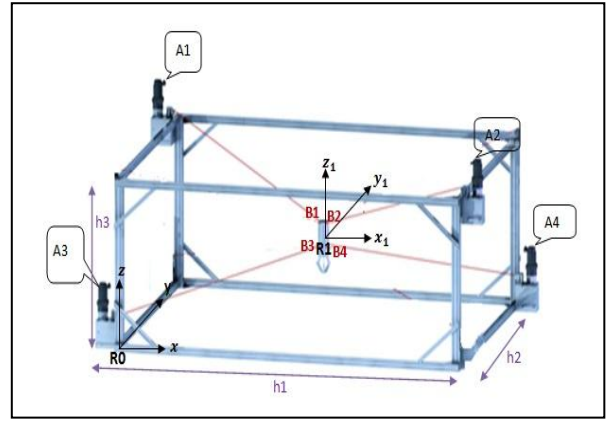

Fig 2. Cables Robot with 4 motors (under-actuated mode).

So, the considered robot contains: four cables connecting the base to the effector moving in six degrees of freedom and four points of cable output, denoted “ $A_i$ ” on the base. Also, there are four attachment points of the cables on the effector, rated “ $B_i$ ”. The vectors  $r_{A_i}$  and  $r_{B_i}$  are the respective coordinates of these points:  $r_{A_i}$  is expressed in the mark  $R_0 = \{0, x, y, z\}$  and  $r_{B_i}$  in the mark  $R_1 = \{0_1, x_1, y_1, z_1\}$ . This paper focuses thereafter on modelling to develop a robust model with fewer parameters and variables. An extension to the feedback control based on observer with a reference position vector is given.

## 3. Model of Cables Robot

This part focuses on developing a robust model of the cable robot in under actuated mode while maintaining the same performance in full order. In order to find a state space model, the geometric model and the kinematics and dynamics must be defined [21-22-23].

### 3.1. Geometric Model

Choosing  $A_3$  as the origin of a fixed reference mark  $R_0$  is the second pointer  $R_1$  placed at the gravity of the effector.

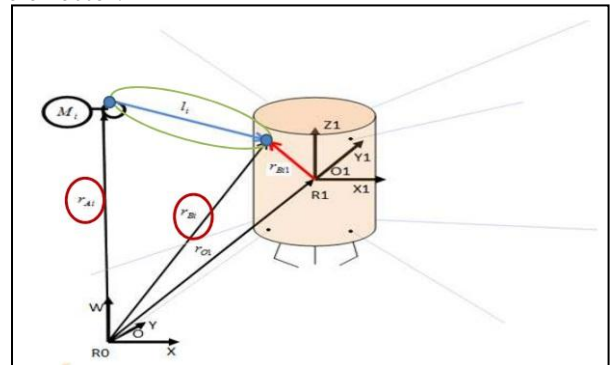

Fig. 3: General Diagram of the system  
As shown in Fig.3, the lengths  $l_i$  of the cables are:

$$l_i = r_{A_i} - r_{B_i} \quad , \quad i = 1, \dots, 4 \quad (1)$$

With :

- $r_{Ai}$  the vector of position of  $A_i$  ( $i = 1, 2, \dots, 4$ ) compared to  $R_0$ .
  - $r_{Bi}$  the vector of position of  $B_i$  (attachment of the cable on the effector,  $i = 1, 2, \dots, 4$ ) compared to  $R_0$ .
- The vectors  $r_{Ai}$  are obtained by a simple projection on the reference mark  $R_0$ .

$$r_{A1} = [0, h_2, h_3]; r_{A2} = [h_1, 0, h_3]; r_{A3} = [0, 0, 0]; r_{A4} = [h_1, h_2, 0]. \quad (2)$$

In the same way, the vectors  $r_{Bi}$  are given after a transformation of the reference mark  $R_1$  towards the reference mark  $R_0$ :

$$r_{Bi} = r_{O1} + R \cdot r_{Bi1} \quad (3)$$

$r_{O1}$  : The vector of position in the beginning  $O_1$  of the reference mark  $R_1$  compared to  $R_0$ .

$R$  : the orientation matrix of the effector compared to the reference mark  $R_0$  with:  $\alpha$  the swing angle compared to axis  $Z$ ,  $\beta$  the swing angle compared to the axis  $Y$  and  $\gamma$  the swing angle compared to axis  $X$ .

$$R = \begin{pmatrix} C\alpha C\beta & C\alpha S\beta S\gamma - S\alpha C\gamma & C\alpha S\beta C\gamma - S\alpha S\gamma \\ S\alpha C\beta & S\alpha S\beta S\gamma + C\alpha C\gamma & S\alpha S\beta C\gamma - C\alpha S\gamma \\ -S\beta & C\beta S\gamma & C\beta C\gamma \end{pmatrix} \quad (4)$$

$r_{Bi1}$  : the vector of position of  $B_i$  compared to  $R_1$ . Using the projection on the reference mark  $R_1$  (Fig.4), the vectors  $r_{Bi1}$  :

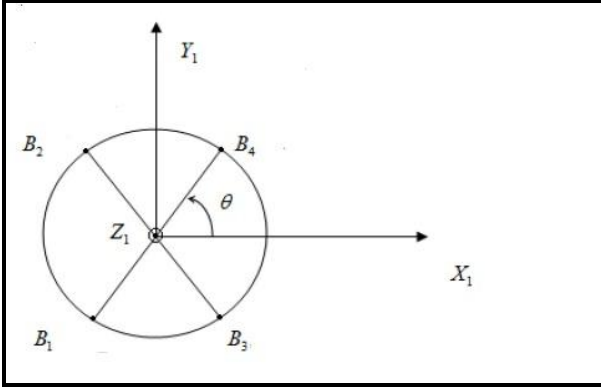

Fig. 4. Connections between the cables and the effector.

$$r_{B11} = [r * \cos(2\theta); r * \sin(2\theta); d]; r_{B21} = [r * \cos(\theta); r * \sin(\theta); d]; r_{B31} = [r * \cos(4\theta); r * \sin(4\theta); -d]; r_{B41} = [r * \cos(\theta); r * \sin(\theta); -d]; \quad (5)$$

### 3.2 Kinematic and dynamic model

The kinematic analysis consists in determining the principal relations between the Cartesian variables and the articular ones of the movement of the robot. This model is obtained by deriving the geometric model described above in which the Jacobian matrix is defined as the ratio between the speed of the actuator

and the speed of the driven cable. The kinematic problem consists in determining the variations in the lengths of cables:

$$\dot{i} = [\dot{i}_1 \quad \dot{i}_2 \quad \dot{i}_3 \quad \dot{i}_4]^T \quad (ms^{-1}) \quad (6)$$

The speed of the effector can be described by:

$$\dot{r}_{O1} = [v \quad w] = \begin{bmatrix} \dot{x} & \dot{y} & \dot{z} & \dot{\alpha} & \dot{\beta} & \dot{\gamma} \end{bmatrix}^T \quad (7)$$

With  $v = [x \quad y \quad z]^T \quad (m.s^{-1})$  is the speed of the gravity centre of the effector and  $w = [\alpha \quad \beta \quad \gamma]^T \quad (rad.s^{-1})$  its angular velocity. Then the kinematic model is [17-21]:

$$\dot{i} = J \cdot \dot{r}_{O1} \quad (8)$$

Where the Jacobian matrix  $J$  is given by:

$$J = \left[ \frac{\partial l_i}{\partial x} \quad \frac{\partial l_i}{\partial y} \quad \frac{\partial l_i}{\partial z} \quad \frac{\partial l_i}{\partial \alpha} \quad \frac{\partial l_i}{\partial \beta} \quad \frac{\partial l_i}{\partial \gamma} \right]; i = (1, 2, 3, 4) \quad (9)$$

The general dynamic equations of the movement can be obtained starting from the formulation of Lagrange whose equation can be written, by taking account of the generalized forces or the couples, in the following form [21-22]:

$$\tau = \frac{d}{dt} \left( \frac{\partial T(q, \dot{q})}{\partial \dot{q}} \right) - \frac{\partial T(q, \dot{q})}{\partial q} + \frac{\partial V(q)}{\partial q} \quad (10)$$

- The variables  $q$  and  $\dot{q}$  are respectively the position and velocity vectors.
- $V$  being potential energy and  $T$  kinetic energy of the system, where:

$$T = \frac{1}{2} m v^T v + \frac{1}{2} w^T R I_{O1} R^T w \quad (11)$$

$I_{O1}$  is the tensor of inertia at the origin of the  $R_1$  reference mark:

$$I_{O1} = \begin{bmatrix} I_{xx} & -I_{xy} & -I_{xz} \\ -I_{yx} & I_{yy} & -I_{yz} \\ -I_{zx} & -I_{zy} & I_{zz} \end{bmatrix} \quad (12)$$

In this study, each cable is supposed to be an element of force. Consequently, the potential energy of the system is due only to the forces of gravitation. This energy is expressed by [18] :

$$V = m \cdot g \cdot z \quad (13)$$

('m' is the mass of effector and 'g' the gravity acceleration).

The relations between the outside of the effector and the tensions of the cables which are necessary to maintain the system in balance are given by the following relation:

$$\begin{bmatrix} F_x & F_y & F_z & M_\alpha & M_\beta & M_\gamma \end{bmatrix} = -J^T u \quad (14)$$

With:

- $F_x, F_y, F_z$ : external forces on the effector in a reference point.
- $M_\alpha, M_\beta, M_\gamma$ : External moments on the effector.
- $u$ : control vector.

Following a series of transformations and substitutions and after the simplification of expression (14), the equation of the movement is expressed by the following general form [20-21]:

$$M(q)\ddot{q} + C(q, \dot{q})\dot{q} + G(q) + \tau_d = -J^T u \quad (15)$$

Where:

$$M(q) = \begin{pmatrix} mI_{3 \times 3} & 0_{3 \times 3} \\ 0_{3 \times 3} & E^T I_{O1} E \end{pmatrix};$$

$$C(q, \dot{q}) = \begin{pmatrix} 0_{3 \times 3} & 0_{3 \times 3} \\ 0_{3 \times 3} & E^T I_{O1} \dot{E} + E^T (\dot{E} \theta)_x (I_{O1} E) \end{pmatrix};$$

$$G(q) = \begin{pmatrix} 0 \\ 0 \\ mg \\ 0_{3 \times 1} \end{pmatrix}; E = \begin{pmatrix} C \beta C \gamma & -S \gamma & 0 \\ C \beta S \gamma & C \gamma & 1 \\ -S \beta & 0 & 1 \end{pmatrix};$$

$$(\dot{E} \theta) = \begin{pmatrix} 0 & -w_z & w_y \\ w_z & 0 & -w_x \\ -w_y & w_x & 0 \end{pmatrix}$$

$\tau_d$ : Vector of the terms of the external disturbances.

### 3.3 State Space Model

Using the dynamic model found, let's consider:

$$\begin{cases} x_1 = q = [x & y & z & \alpha & \beta & \gamma]^T \\ x_2 = \dot{q} \end{cases} \quad (16)$$

Using eq (14) and  $\bar{x} = [x_1 \quad x_2]^T$ :

$$\begin{aligned} \dot{\bar{x}} &= \begin{pmatrix} \dot{x}_1 \\ \dot{x}_2 \end{pmatrix} = \begin{pmatrix} f_1(\bar{x}, u) \\ f_2(\bar{x}, u) \end{pmatrix} \\ &= \begin{pmatrix} x_2 \\ -M^{-1}(\bar{x}) [C(\bar{x})x_2 - G(\bar{x}) - J(\bar{x})^T u - \tau_d] \end{pmatrix} = f(\bar{x}, u) \end{aligned} \quad (17)$$

Eqs (16) and (17) can be rewritten easily in this basic discrete-time form using Euler discretization with a step size  $T_e$ :

$$\begin{cases} \bar{x}_{k+1} = A \bar{x}_k + T_e f(\bar{x}_k, u, \zeta_k) \\ y_k = x_{1k} + \xi_k \end{cases} \quad (18)$$

Where  $A = I_{12}$ .

### 4. Extension to State Estimation and Feedback control

In this section an extension to state estimation and control will be presented. The strategy is like a feedback control based on observer [26-27] but in an iterative way (online and not after an observer gain calculated offline).

The main problem in dynamic state estimation of cables robot is that few methods are applicable. Effectively, the numerous and strong nonlinearities in presence lead generally to the use of EKF to resolve the state estimation problem. The advantages of the EKF are its simplicity. The fact is that it is a recursive algorithm and its computational load is modest too. The EKF is suitable for real-time industrial-scale applications with the development of the DSP devices.

A simple version of EKF used as an estimator (EKE) is given by [14]:

$$\begin{aligned} \hat{x}_{k+1} &= f(\hat{x}_k, u_k) + K_k e_k \\ K_k &= F_k P_k H_k^T (H_k P_k H_k^T + R_k)^{-1} \\ P_{k+1} &= (F_k - K_k H_k) P_k F_k^T + Q_k \end{aligned} \quad (19)$$

$$e_k = y_k - h(\hat{x}_k, u_k)$$

Where  $F_k = F(\hat{x}_k, u_k) = \frac{\partial f(\bar{x}_k + T_e f(\bar{x}_k, u_k))}{\partial \bar{x}_k} \Big|_{\bar{x}_k = \hat{x}_k}$

and  $H_k = H(\hat{x}_k, u_k) = I_6 \Big|_{\bar{x}_k = \hat{x}_k}$

$R_k$  and  $Q_k$  are respectively the covariance matrix of the system noises ( $\zeta_k$ ) and measurements ( $\xi_k$ ). A proof of convergence of this Filter is given with details in [14] where the matrices  $Q_k$  and  $R_k$  are chosen as follows:

$$\begin{aligned} Q_k &= \eta e_k^T e_k I_n + \nu I_n \\ R_k &= \epsilon H_k P_k H_k^T + \mu I_m \end{aligned} \quad (20)$$

where  $\eta$  and  $\nu$  have to be chosen large and positive and  $\epsilon$  and  $\tau$  a positive scalar fixed by the user.

For the synthesis of the control law, the simplest classical expression commonly used is as follows:

$$u = -(J^T)^{-1} \left[ M(q)\ddot{q} + C(q, \dot{q})\dot{q} + G(q) + \tau_d \right] \quad (21)$$

**Remark:**

However in some cases the  $J$  matrix is not invertible (The term  $(J^T)^{-1}$  does not exist). The solution is the use the pseudo-inverse of this matrix  $(J(JJ^T)^{-1})$ .

Similarly for the term  $M^{-1}(\bar{x})$ .

Now, for the sequence of control taking into account a desired vector ( $q_d = [x_d \ y_d \ z_d \ \alpha_d \ \beta_d \ \gamma_d]^T$ ), with the use of equation (21) and the estimated state vector ( $\hat{x}$ ), it's simple to find an expression of ' $u^*$ ' ensuring a desired vector  $q_d$ :

$$u^* = -J(JJ^T)^{-1} \left[ M(\hat{q} - q_d)\ddot{\hat{q}} + C(\hat{q} - q_d, \dot{\hat{q}})\dot{\hat{q}} + G(\hat{q} - q_d) + \tau_d \right] \quad (22)$$

The expression (22) can be easily generalized for discrete time systems.

**5. Simulation Results**

The considered robot in this work is composed of four cables (as shown in Figure 2) connecting a parallelepiped base of form of four engines to an effector of mobile cylindrical form to six degrees of freedom.

The different parameters of this cables robot are:

- \* Mass  $m = 20kg$ ; Gravity  $g=9.81$
- \* Dimensions of the base are:  $h1 = 400 \text{ cm}$ ;  $h2 = 200 \text{ cm}$ ;  $h3 = 200 \text{ cm}$ .
- \* The ray  $r$  of the effector, the distance  $d$  between the gravity centre and a  $Bi$  point and the angle  $\theta$  which separates two points from the cables with the effector compared to the reference mark  $R_i$  are respectively:

$$d=10; r=5; \theta = \frac{\pi}{3};$$

**5.1 Model Validation**

The purpose of this part is to validate the model of the cable robot proposed in this paper (geometric & dynamic described in Section 3). The parameters defined above make it possible to determine the geometric model of the robot (defined in section 3.1). This model, therefore, allows the determination of the cable lengths given by equation (1).

Let us assume that the effector is in the middle of the fixed base:

$$r_{O1} = \left[ \frac{h_1}{2} \quad \frac{h_2}{2} \quad \frac{h_3}{2} \quad 0 \quad 0 \quad 0 \right]^T$$

With :

$$I_{O1} = \begin{bmatrix} I_{xx} & -I_{xy} & -I_{xz} \\ -I_{yx} & I_{yy} & -I_{yz} \\ -I_{zx} & -I_{zy} & I_{zz} \end{bmatrix} = \begin{bmatrix} 0.782 & 0 & 0 \\ 0 & 0.782 & 0 \\ 0 & 0 & 0.293 \end{bmatrix}$$

Now by deriving the geometric model and knowing the value of the Tensor of Inertia, we can easily solve the the dynamics equation (15) of the robot (dynamic model given in Section 3.2). Furthermore, the application of a control makes it possible to move the effector with a position defined by  $q_d$ . For example, to move the effector towards the desired position and the orientation:  $[100 \ 150 \ 100 \ 30 \ 60 \ 30]^T$ , we apply the control law given by equation (21). The result of the simulation (the position of the effector) is given in Figure 5:

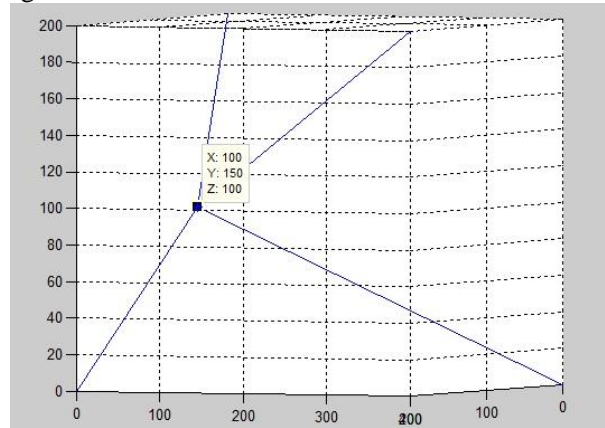

Fig. 5. The Effector in the desired position

Where the lengths of cables are:

$$\begin{cases} l_1 = [210.9583 & -101.4537 & -98.3259]^T; \\ l_2 = [-191.6631 & 105.6156 & -104.895]^T; \\ l_3 = [189.796 & 96.7593 & 96.7787]^T; \\ l_4 = [-209.0912 & -100.9212 & 106.4422]^T; \end{cases}$$

It is clear after this simulation that the proposed Under-Actuated model achieves the desired position with only 4 motors and cables.

**5.2 Feedback control**

This section focuses on the control based on observer (EKF used as an estimator based on equation (19)) with a desired position vector  $q_d : [100 \ 90 \ 80 \ 60 \ 30 \ 30]^T$ . This control strategy is articulated on State Space Model defined in equation (18). For discretization, the

step size is equal to  $T_e=0.01s$ . The initial estimated state vector was selected as follows:

$$\hat{x}_k(0) = [180 \ 100 \ 100 \ 10 \ 10 \ 10 \ 1 \ 1 \ 1 \ 0 \ 0 \ 0]^T$$

In this phase of simulation, a noise was added to the system ( $\tau_d=0.5*I_{12}$ ) and output: sinusoidal signal with variable frequencies (between 10 Hz and 140 Hz) and amplitude ( $\pm 3\%$  of the real value of  $y$ ). We consider these proposed values of  $Q_k$  and  $R_k$  based on equation (20):

$$\begin{aligned} Q_k^{E.K.F} &= 100e_k^T e_k I_{12} + 10^{-3} I_{12} \\ R_k^{E.K.F} &= 10H_k P_k H_k^T + 10^{-3} I_6 \end{aligned} \quad (23)$$

Figs. 6-7 present respectively the real state  $x_1(k)$  and its estimated and the control  $u_1(k)$  based on equations (19) and (22).

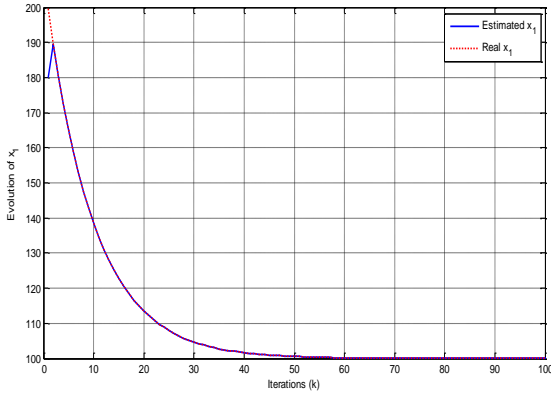

Fig. 6. Response of real  $x_1(k)$  and its estimate.

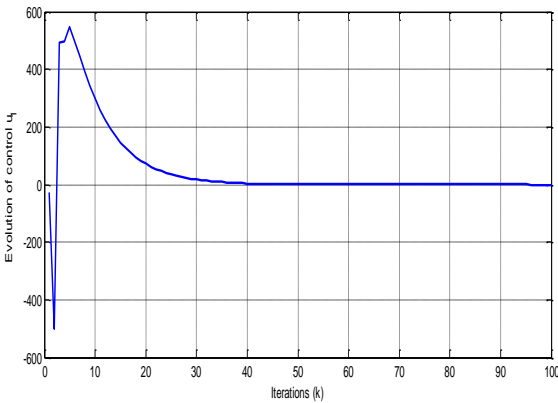

Fig. 7. Evolution of  $u_1(k)$ .

Figures 6 and 7 show that the control sequence stabilizes the system. The estimated state converges to real one with a guaranteed desired vector (position vector) without error or biased result. Now, the added noise to the system ( $\tau_d=0.5*I_{12}$ ) and output are a sinusoidal signals with variable frequencies (between 10 Hz and 140 Hz) and amplitude ( $\pm 10\%$  of the real

value of  $y$ ). Figure 8 presents the evolution of error estimation ( $x_{10}(k) - \hat{x}_{10}(k)$ ):

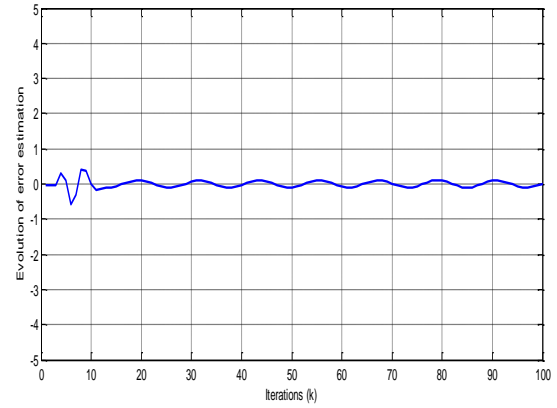

Fig. 8: Evolution of error estimation

It's clear from Fig 8 that the EKF used as an estimator with the proposed choice of  $Q_k$  and  $R_k$  (eq (23)) ensure good performances with error estimation converges to 0 in the presence of noise.

### 5.3 Comparative Study

In order to prove the contribution acquired on the convergence, let us consider the same proposed system. First, we have tested the proposed approach compared to [16] while considering the same noise in the first part of simulation. Figure 9 presents the response of  $\hat{x}_4(k)$ .

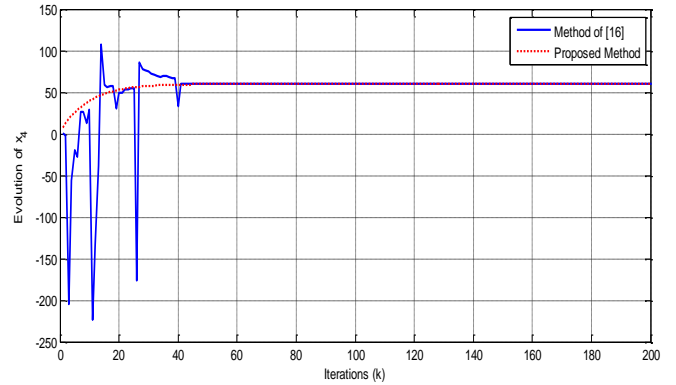

Fig. 9. Response of  $\hat{x}_4(k)$ .

Figure 9 shows that the method of [16] presents a high pick on transient regime with little noise compared to the proposed approach.

Second, we increase the vector ( $\tau_d=\lambda*I_{12}$ ) while considering the same noise in the first part of simulation. Then, these conditions lead to the following comparative Table 1 (where in **C** there is a solution ensuring convergence and in **D** there is divergence):

Table 1. The result of Convergence with variables “ $\lambda$ ”.

$\lambda$	1	5	10	15
Proposed Method	C	C	C	C
Method of [16]	C	C	Biased	D

From Table 1, it is clear that the proposed method ensures convergence with a large value of “ $\lambda$ ” compared to the method of [16].

## 6. Conclusion

Efficient robust model for a cables robot is presented in this paper. The use of the under-actuated mode has ensured the stability and the same performances of full order model. A very simple strategy of control based on EKE with a desired position vector has confirmed the high quality of estimation and control offered with the presence of noises where the amplitudes and frequencies are variable. The remaining open question is: the application of the proposed method to a large scale of decentralized/distributed cables robots and the real time implementation? This issue will be investigated in the near future.

## Acknowledgments

The authors would like to thank:

\* M. Hannachi and M. Daboussi (PhD students), University of Gabes-Tunisia & Y. Bouajila University of Lorraine-France, for their valuable suggestions regarding the placement of engines in cable robots.

\* The French Institute of Tunisia (“*Institut Français de Tunisie*”) for its financial support.

## Nomenclature

EKF: Extended Kalman Filter.

EKE: Extended Kalman Estimator.

DSP: Digital Signal Processing.

Dll: degrees of freedom.

SODTSM: Second Order Discrete-Time Sliding Mode.

C: cos(.)

S: sin(.)

## References

1. Groover M.P : *Automation, Production Systems, and Computer-Integrated Manufacturing*, Prentice Hall, NJ, USA, 2007.
2. Borenstein J., Feng L., Everett H.R : *Navigating Mobile Robots: Systems and techniques*, AK Peters, MA, USA,

1996.

3. Diao X., Ma O., : *Vibration analysis of cable-driven parallel manipulators*, *Multibody Syst. Dyn.*, Vol. 21, (2009), p. 347-360.
4. Kawamura S., Kino H., Won C.: *High-speed manipulation by using parallel wire-driven robots*, *Robotica*, Vol. 18, (2000), p.13-21.
5. Oh S., Agrawal S.K. : *Cable Suspended Planar Robots with Redundant Cables: Controllers With Positive Tensions*, *IEEE Trans. on Robotics*, Vol. 21, No. 3, (2005), p. 457-465.
6. Wu J, Wang J, Wang L, Li T: *Dynamics and control of a 3-DOF parallel manipulator with actuation redundancy*, *Mechanism and Machine Theory*, Vol. 44, (2009), p. 835-849.
7. Khosravi M.A., Taghirad H.D : *Robust PID control of fully-constrained cable driven parallel robots*, *Mechatronics*, Vol. 24, (2014), p. 87-97.
8. Oh S., Agrawal S.K : *Generation of Feasible Set Points and Control of a Cable Robot*, *IEEE Trans. on Robotics*, Vol. 22, (2006), p.551-558.
9. Hwang J.P, Kim E : *Robust tracking control of an electrically driven robot: adaptive fuzzy logic approach*, *IEEE Trans Fuzzy Syst*, Vol. 14(2), (2006), p. 232-247.
10. Rodriguez A, Nijmeijer H.: *Mutual synchronization of robots via estimated state feedback: A cooperative approach*, *IEEE Trans. on Control. Syst. Technology*, vol. 12 (4), (2004), p. 542-554.
11. Yao J., Jiao Z., Ma D.: *Extended state observer based output feedback nonlinear robust control of hydraulic systems with backstepping.*, *IEEE Trans. on Industrial Electronics*, vol. 61 (11), (2014), p. 6285-6293.
12. Fernandes D., Sorensen A, Pettersen K, Donha D: *Output feedback motion control system for observation class rovs based on a high-gain state observer: Theoretical and experimental results*, *Control Eng. Practice*, vol. 39, 2015, p. 90-102.
13. Thabet A, Boutayeb M, Didier G, Chniba S, Abdelkrim M.N. : *Fault detection and isolation for nonlinear dynamic power system*, *Int. Rev. of Automatic Control*, Vol. 4, (2011), p. 610-619.
14. Thabet A., Boutayeb M., Abdelkrim M.N : *Real time dynamic state estimation for power system*, *Int. J. of Computer Applicatons*, Vol. 38, (2012), p.11-18.

15. Davila J, Fridman L, Levant A : *Second-Order Sliding-Mode Observer for Mechanical Systems*. IEEE Trans. on Automatic Control, Vol. 50, N° 11, (2005), p. 1785-1789.
16. Kim D, Koo K, Jeong J.J, Goh T, Kim S.W, : *Second-Order Discrete-Time Sliding Mode Observer for State of Charge Determination Based on a Dynamic Resistance Li-Ion Battery Model*, Energies, (2013), Vol. 6, p. 5538-5551.
17. Zi B, Duan B.Y, Du J.L, Bao H : *Dynamic modeling and active control of a cable suspended parallel robot*. Mechatronics, Vol. 18, (2008), p. 1–12.
18. Lamaury J. : *Contribution à la commande des robots parallèles à câbles à redondance d'actionnement* (Contribution to the control of parallel cables robots with actuating redundant), PhD Thesis, l'Université Montpellier II - Sciences et Techniques du Languedoc, 2013.
19. Duan B, Ying Y.Q, Zhang F.S, Zi B : *On Design and Experiment of the Feed Cable-Suspended Structure for Super Antenna*, Mechatronics, vol. 19, (2009), p.503-509.
20. Cunningham D, Asada H, : *A Cable-Suspended, Under-Actuated Robot Utilizing Parametric Self-Excitation*, Proceedings of the IEEE International Conference on Robotics and Automation' 09, May 12-17, 2009, Japan, p. 1844-1850.
21. Gosselin C, Lefrançois S, Zoso N, : *Under-actuated cable-driven robots : machine, control and suspended bodies*, Proceedings of the CIM Symposium on Brain, Body and Machine'10, November 10-13, 2010, Canada, p. 311-323.
22. Miermeister P., Kraus W., Lan T. and Pott A. : "An Elastic Cable Model for Cable-Driven Parallel Robots Including Hysteresis Effects". Chapter Cable-Driven Parallel Robots, Vol 32 of the series Mechanisms and Machine Science, pp 17-28, 2015.
23. Khosravi M.A, Taghirad H.D : "Dynamic Modeling and Control of Parallel Robots with Elastic Cables: Singular Perturbation Approach". IEEE Trans on Robotics, Vol 30 N°3, 2014, pp. 694-704.
24. Duriez C., Bieze T. *Soft Robot Modeling, Simulation and Control in Real-Time*. In: Laschi C., Rossiter J., Iida F., Cianchetti M., Margheri L. (eds) Soft Robotics: Trends, Applications and Challenges. Biosystems & Biorobotics, vol 17. Springer, Cham, 2017.
25. Duriez, C.: *Control of elastic soft robots based on real-time finite element method*. In: Proceedings of IEEE International Conference on Robotics and Automation'13, May 06-10, 2013, Germany, pp. 3982–3987.
26. Thabet A, Frej G.B.H, Boutayeb M, : *Observer-Based Feedback Stabilization for Lipschitz Nonlinear Systems With Extension to  $H_\infty$  Performance Analysis: Design and Experimental Results"*. IEEE Trans on Cont. Syst. Techn., (2017), Vol PP (99), p. 1-8.
27. Frej G.B.H, Thabet A, Boutayeb M, Aoun M, : *Decentralized Observers for Optimal Stabilization of Large Class of Nonlinear Interconnected Systems*. Int. J. of Computers Applications, New York, (2016), Vol 137 (14), p. 1-7.