

ANALYSIS OF C-SHAPE COMPACT MICROSTRIP LINE FED RECTANGULAR PATCH ANTENNA FOR DUALBAND OPERATION

Sayed SALIM SAYEED, Ashish SINGH*, Kamakshi, Mohd. ANEESH, J. A. ANSARI

Department of Electronics and Communication

University of Allahabad, Allahabad, India

Email-ashsin09@rediffmail.com*

Abstract- In the paper, analysis of microstrip line fed compact C-shape rectangular patch antenna is proposed. The proposed antenna shows dual band operation which depends on notch dimensions as well as length and width of microstrip line. The frequency ratio is obtained to be 4.0 for proposed antenna. The characteristics comparison of reported and proposed antenna parameters has been presented. The theoretical results are compared with simulated results and they are in close agreement.

Keywords- Microstrip Line fed, Notch, Dual-band, Microstrip Patch Antenna (MSA).

1. Introduction

Today the world lives in a completely dependent environment, where the use of modern communication systems is becoming essential in everyday routine. In particular, the field of wireless communications is experiencing unprecedented growth evident from the increase in use of cellular phones, Wireless Local Area Networks (WLAN), Global Positioning Systems (GPS) and Satellite Telephones. Moreover, advancement in electronic warfare revolutionized the wireless communications through cutting edge technologies like Space-Based Radar, Communication Satellites, and Electronic Intelligence. This advancement in wireless communication is due to the rapid development of microwave integrated circuits this embed all the circuit components same circuit board such as resistor, inductor, capacitor and microstrip patch antenna (MSA). MSA is one of important device in the field of communication. Single MSA can be used in more than application for data communication [1-6]. Only limited research papers has been reported using microstrip strip line fed patch antenna for dualband and multiband operation [7-23]. In these reported papers of microstrip line feeding patch antenna which lacks theoretical analysis, equivalent circuit diagram and has complicated radiating structures.

A novel microstrip line fed compact C-shaped rectangular patch antenna is proposed for dual-band frequency operation. The main objective of this paper is to present theoretical analysis, equivalent circuit diagram and total input impedance of the proposed antenna. The proposed antenna is compared with

similar radiating geometer [22]. In the next section, antenna design, analysis of radiating structures, circuit diagram discussion of results and conclusion of proposed antenna are discussed in detail.

2. Antenna Structures and Design Specification

2.1 Antenna Designs

The reported antenna consists of split ring resonator (SRR) and parasitic element which is excited by 50Ω microstrip line fed [22] and is shown in Fig.1(a). A rectangular C-shape compact microstrip patch antenna is proposed and shown in Fig. 1(b) and design specifications of proposed and reported antennas are given in Table I. The notch is loaded on the rectangular patch which is fed through 50Ω microstrip line via coaxial cable. Figure 2 shows the current distribution around the notch and edges of patch for lower (0.92 GHz) and higher (3.6 GHz) resonance frequencies.

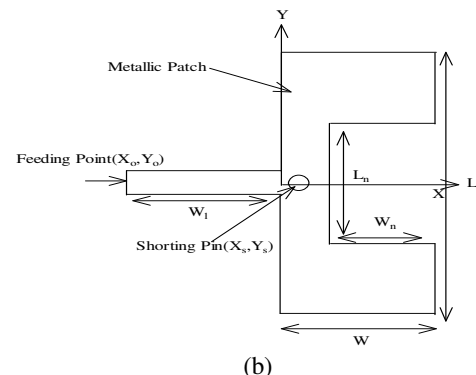
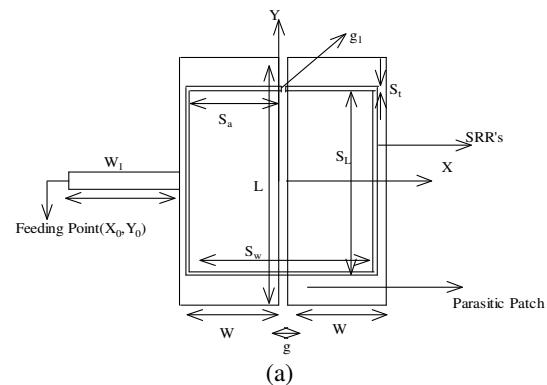

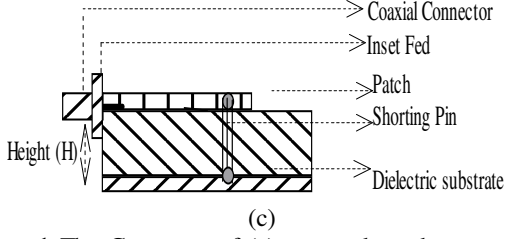

Figure 1 The Geometry of (a) reported patch antenna and (b) Top View (c) Side View of proposed patch antenna.

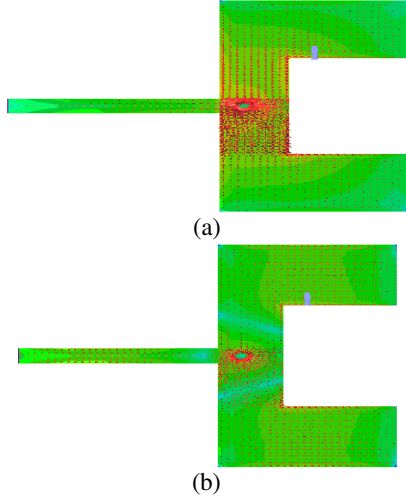

Figure 2 Current distribution (a) Lower and (b) higher resonance frequency.

2.2 Design Specifications

TABLE-I Design Specifications of reported and proposed microstrip patch antennas.

Thickness of dielectric substrate(H)	1.5 mm
Permittivity of Substrate(ϵ_r)	2.65
Loss tangent of substrate ($\tan\delta$)	0.0015
Width of patch (W)	23 mm
Length of patch (L)	58 mm
Width of microstrip line(W_s)	4.0 mm
Notch length(L_n)	26 mm
Notch width(L_w)	14.5 mm
Length of Microstrip line(L_s)	26.5 mm
Shorting Pin(X_s, Y_s)	(-8.5,0)
Gap between the feed patch and parasitic patch (g)	4.0 mm
Length of SRR's (S_L)	25.6 mm
Width of SRR's (S_w)	25.6 mm
Width of both SRR's arm (S_a)	12.65 mm
Length of SRR's arm (S_l)	0.5 mm
Gap between two SRR's arms(g_1)	0.5 mm

3. Analysis of compact notch loaded microstrip line fed patch antenna

A rectangular microstrip patch is considered as a parallel combination of resistance (R_1), inductance

(L_1), and capacitance (C_1) is shown in Fig.3 (a) and calculated as [23-24].

$$C_1 = \frac{LW \epsilon_0 \epsilon_e \cos^2 \left(\frac{\pi X_0}{L} \right)}{2H}, \quad (1)$$

$$R_1 = \frac{Q}{\omega_r^2 C_1}, \quad (2)$$

$$L_1 = \frac{1}{C_1 \omega_r^2}, \quad (3)$$

$$\text{Quality factor, } Q = \frac{c \sqrt{\epsilon_e}}{4 f H}$$

L- Length of rectangular patch

W- Width of rectangular patch

H- Thickness of the substrate material

X_0 - y coordinates of feed point

ϵ_e - effective permittivity of the medium.

3.1 Microstrip line

The microstrip line of the rectangular strip is considered parallel combination of inductance L and capacitance C. The equivalent circuit of the microstrip line rectangular patch is shown in Fig. 3(b), where L_L and C_L are inductance and capacitance of strip [24-25].

$$L_L = 100 .H (4 \sqrt{W_s / H} - 4.21) nH, \quad (4)$$

$$C_L = W_s \{ (9.5 \epsilon_r + 1.25) W_s / H + 5.2 \epsilon_r + 7.0 \} pF, \quad (5)$$

Resonance frequency of the microstrip line antenna is given as

$$f = c / 2L_e \sqrt{\epsilon_{re}}, \quad (6)$$

where

$$\epsilon_{re} = 1/2[(\epsilon_r + 1) + (\epsilon_r - 1)(1 - 12.H / W_s)^{-1/2}],$$

$$L_{es} = L_s + \Delta L_s,$$

ϵ_{re} - Effective dielectric constant

L_{es} -Effective increase in length of strip

$$\Delta L_s = H .0.412 \frac{(\epsilon_{re} + 0.3)(W_s / H + 0.264)}{(\epsilon_{re} - 0.258)(W_s / H + 0.8)},$$

ϵ_r -Dielectric constant,

The characteristic impedance of microstrip line can be given as,

$$Z_L = j\omega L_L + \frac{1}{j\omega C_L + \frac{1}{j\omega L_L}} \quad (7)$$

3.2 Loading of notch

When a notch is etch on the patch, current distribution of radiating structure change in comparison to the normal radiating patch. Thus due to this two current flows of different length, one current flow normal to the patch and resonates at the design

frequency of the initial patch, and other current flows around the notch results in second resonance frequency and is shown in Fig.2. Therefore, this perturbation modifies the equivalent circuit of the initial patch as an additional series inductance (ΔL) and series capacitance (ΔC) [26-27] is added, as shown in Fig.3(c) the equivalent circuit of notch.

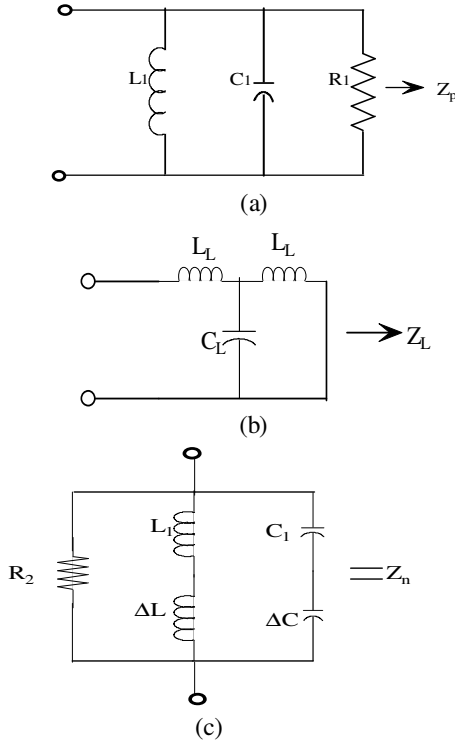

Figure. 3 Equivalent circuit of (a) simple patch (b) Microstrip line and (c) notch.

$$\Delta L = \frac{H\eta\pi}{8} (L_n / W_n), \quad (8)$$

$$\Delta C = \left(\frac{L_n}{W_n}\right) C_g, \quad (9)$$

where $\mu = 4\pi \times 10^{-7}$ H/m,

C_g = gap capacitance [25]

The input impedance of notch loaded on the antenna can given as,

$$Z_n = \frac{1}{\frac{1}{R_2} + j\omega C_2 + \frac{1}{j\omega L_2}}, \quad (10)$$

The value of R_2 resistance [11] after cutting the notch is calculated. L_m and C_m are mutual inductance and capacitance [26-27] between the two resonators which is given as,

$$L_m = \frac{k_c^2(L_1+L_2) + [k_c^4(L_1+L_2)^2 + 4k_c^4(1-k_c^2)L_1L_2]^{1/2}}{2(1-k_c^2)}, \quad (11)$$

$$C_m = \frac{-(C_2+C_1) + [(C_2+C_1)^2 + (1-1/k_c^2)C_1C_2]^{1/2}}{2}, \quad (12)$$

The mutual impedance can given as,

$$Z_m = j\omega L_m + \frac{1}{j\omega C_m}, \quad (13)$$

where

$$L_2 = \frac{L_1\Delta L}{L_1 + \Delta L}, \quad C_2 = C_1 + \Delta C,$$

$$k_c = \frac{1}{\sqrt{Q_1Q_2}},$$

$$Q_1 = R_1 \sqrt{\frac{C_1}{L_1}},$$

$$Q_2 = R_2 \sqrt{\frac{C_2}{L_2}},$$

Q_1 and Q_2 are quality factor for both the resonators.

3.3 Loading of shorting pin

On loading shorting pin on the patch, a parallel inductance L_s is added on the patch, the equivalent circuit of rectangular patch antenna with shorting pin is shown in Fig 4. The value of L_s [24] can be given as,

$$L_s = \frac{\eta_0 W L}{2\pi \cdot c} \ln\left[\frac{4 \cdot c}{E W d \sqrt{\epsilon_r}}\right] \quad (14)$$

where,

c - speed of light,

d - diameter of shorting pin,

E - Euler constant,

$\eta_0 = 120 \cdot \pi$,

The impedance of shorting pin loaded patch from fig. 4, is given as

$$Z_{ps} = \frac{1}{\frac{1}{R_1} + \frac{1}{j\omega L_1} + \frac{1}{j\omega L_s} + j\omega C_1}, \quad (15)$$

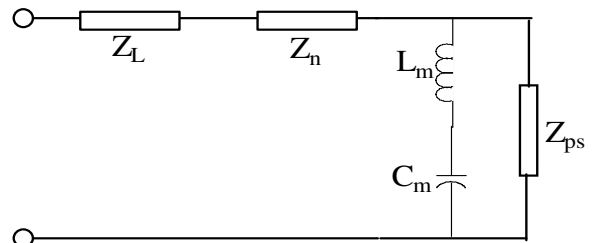

Figure. 4 Equivalent circuit of proposed antenna.

Therefore, the total input impedance (Z_{in}) of antenna can calculate by equivalent circuit diagram as shown in Fig 4,

$$Z_{in} = Z_L + Z_n + \frac{Z_{ps} \cdot Z_m}{Z_{ps} + Z_m} \quad (16)$$

Now using equation (16) the total input impedance of the proposed antenna and reported antenna respectively. Their various antenna parameters such as reflection coefficient, VSWR and return loss can be calculated as,

$$\text{Reflection Coefficient } \Gamma = \frac{Z - Z_{in}}{Z + Z_{in}},$$

where

Z is the input impedance of the microstrip fed (50 Ω).

$$\text{VSWR} = \frac{1 + \Gamma}{1 - \Gamma},$$

and RL=20 log |r|

4. Radiation Pattern

The radiation pattern for microstrip line fed rectangular patch antenna is calculated as [23-24].

$$E(\theta) = \frac{-jk_0 W V e^{jk_0 r}}{\pi} \cos(k_0 h \cos\theta) \frac{\sin\left(\frac{k_0 W}{2} \sin\theta \sin\phi\right)}{\frac{k_0 W}{2} \sin\theta \sin\phi} \times \cos\left(\frac{k_0 l}{2} \sin\theta \sin\phi\right) \cos\phi$$

(0 ≤ θ ≤ π/2)

(17)

$$E(\phi) = \frac{-jk_0 W V e^{jk_0 r}}{\pi} \cos(k_0 r \cos\theta) \frac{\sin\left(\frac{k_0 W}{2} \sin\theta \sin\phi\right)}{\frac{k_0 W}{2} \sin\theta \sin\phi} \times \cos\left(\frac{k_0 l}{2} \sin\theta \sin\phi\right) \cos\phi \sin\phi$$

(0 ≤ θ ≤ π/2)

(18)

where ,

V is radiating edge voltage

r is the distance of an arbitrary point.

$$k = k_0 \sqrt{\epsilon_r}$$

$$k_0 = \frac{2\pi}{\lambda}$$

Similarly for two dielectric layers microstrip patch antenna.

$$k = k_0 \sqrt{\epsilon_{re}},$$

where

ϵ_{re} is the effective permittivity for driven patch.

$$E_{\text{total}} = E(\theta)^2 + E(\phi)^2$$

5. Discussion of Results

Figure 5 shows the comparison between the reported and proposed antenna. It is observed that both antennas give dualband operation. The reported and proposed antenna resonated at 0.9/1.8 GHz and 0.9/3.6 GHz respectively and these can be utilized for wireless communication. Reason behind the comparison of the

reported antenna is that the reported antenna has some limitation that can be overcome by the proposed antenna such as reduced in area, polarization and gain. Complete comparison details of both antennas are given in Table 2.

Figure 6 shows, the variation of reflection coefficient with frequency for microstrip line fed C-shape compact rectangular patch antenna. It is observed that the simulated and theoretical results are in good agreement. Frequency ratio of simulated and theoretical results is obtained as 3.9 and 4.0 respectively.

From Fig. 7, it is observed that on increasing the thickness of dielectric substrate H= 1.5mm to 2.5 mm the frequency ratio increases from 4.0 to 5.8 whereas decreasing the thickness of dielectric substrate H=1.5 mm to 0.5 mm the frequency ratio of proposed antenna decreases from 4.0 to 1.97.

Figure 8 shows the variation of reflection coefficient with frequency on decreasing ($W_s=4$ mm to 2 mm) and increasing ($W_s=4$ mm to 8 mm) the width of microstrip line, there is no change in the frequency ratio whereas slight shifting is observed at lower and upper resonance frequencies.

From Fig. 9, it is observed that on increasing the length microstrip line ($L_s=21.6$ mm to 29.6mm) higher resonance frequency shift toward lower resonance side whereas no change has been observed at lower resonance frequency. Thus decrease in frequency ratio is observed from 4.0 to 3.4.

Figure 10 shows the variation of reflection coefficient with frequency on decreasing notch width ($N_w=26$ mm to 17 mm) higher resonance frequency shift toward higher side with increase in frequency ratio from 4.0 to 5.39.

From Fig.11 shows the radiation pattern at lower (0.92 GHz) and higher (3.6 GHz) resonance frequency and antenna shows linear polarization.

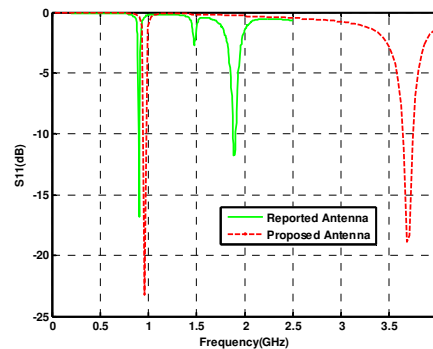

Figure 5 Comparison between reported [22] and proposed antenna.

Table-III Characteristics of Antennas

	Band (GHz) Bandwidth(MHz)	Max. Gain	Polarization	Frequency Ratio
Inset fed microstrip patch antenna with parasitic element and SRR's [22]	0.874-0.943 69 MHz 1.863-1.932 69 MHz	1.8 dBi	Circular	2.0
Proposed inset fed microstrip patch antenna with notch	0.910-0.980 70 MHz 3.646-3.713 67 MHz	3.7 dBi	Linear	4.0

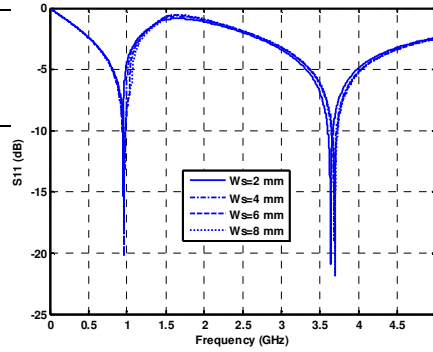

Figure 7 Variation of reflection coefficient (dB) with frequency on varying width of microstrip (W_s) of the proposed antenna.

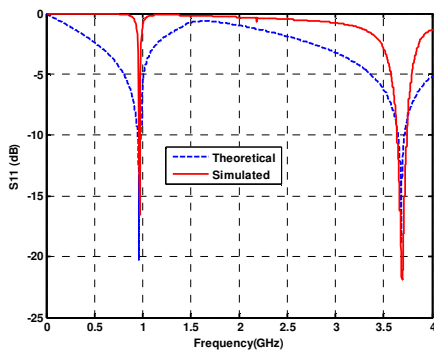

Figure 5 Comparison between theoretical and simulated results [28] of proposed antenna.

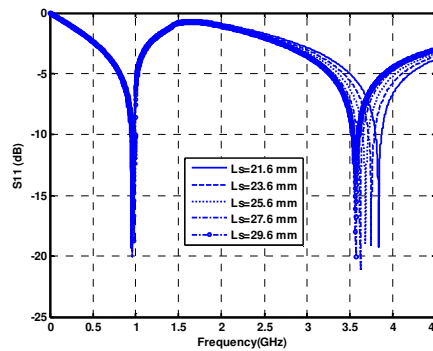

Figure 8 Variation of reflection coefficient (dB) with frequency on varying length of microstrip (L_s) of the proposed antenna.

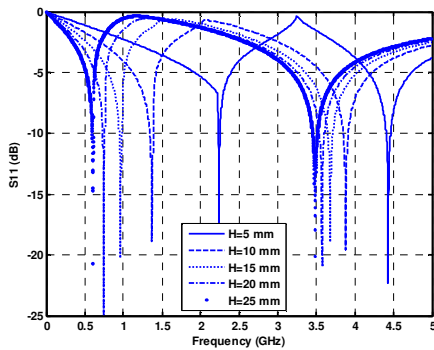

Figure 6 Variation of reflection coefficient (dB) with frequency on varying height (H) of the proposed antenna

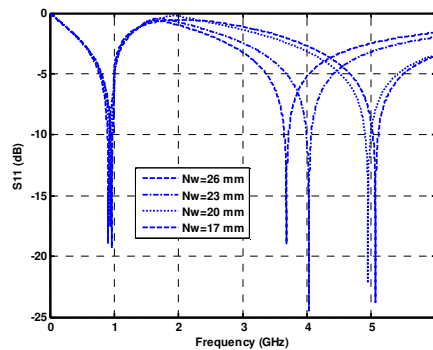

Figure 9 Variation of reflection coefficient (dB) with frequency on varying width of notch (L_w) of the proposed antenna.

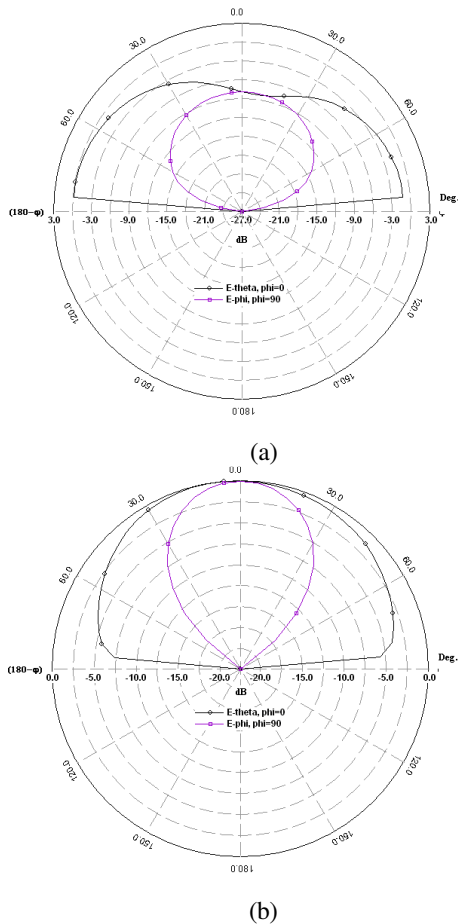

Figure 10 Radiation Pattern of antenna (a) Lower resonance frequency (b) Upper resonance frequency. (E_{θ} , for $\phi=0$ and $\phi=90$ deg).

6. Conclusion

The proposed microstrip line fed compact C-shape rectangular patch antenna is in close agreement with simulated and theoretical results. The frequency ratio of the proposed antenna depends on the notch width and length. The proposed antenna has frequency ratio 4.0 and maximum gain 3.7 dBi. The proposed antennas can be utilized for mobiles and down linking for satellite communications.

References

- [1] I. J. Bahl, S. S. Stuchly, and M. A. Stuchly.: A new microstrip radiator for medical application. *IEEE Trans. Microwave Theory Tech.* Vol. MTT-28, (1980)1464–1468.
- [2] J. C. Batchelor and R. J. Langley, “Microstrip ring antennas operate at higher order modes for mobile communications,” *Proc. Inst. Elect. Eng.*, pt. H, 142(1995) 151–155.
- [3] Herscovivi, N. , Nashua, NH Dziadek, E, “Omni-directional antennas for wireless communication,”

- Antennas and Propagation Society International Symposium, 1, (1999) 556 - 559.
- [4] Chan Hwang See, Raed A. Abd-Alhameed, Dawei Zhou, Ting Hee Lee, and Peter S. Excell, “A crescent-shaped multiband planar monopole antenna for mobile wireless applications,” *IEEE Antennas Wireless Propag. Lett.*, 9 (2010)152-156.
- [5] Meshram ,A. K., Manoj Kumar Meshram, and Babau R. Vishvakarma, “L-Strip proximity fed shorted rectangular microstrip antenna mobile communication,” *Microwave Opt. Technol. Lett.* 52(2010)1567-1571.
- [6] C.J. Sa nchez-Ferna ndez et. al., “Dual-band microstrip patch antenna based on short-circuited ring and spiral resonators for implantable medical devices,” *IET Microw. Antennas Propag.*, 4(2010) 1048–1055.
- [7] Q. Rao, T.A. Denidni, A.R. Sebak and R.H. Johnston, “Microstrip fed single-layered substrate aperture coupled microstrip antenna,” *IEE Proc. Microw. Antennas Propag.*, 152 (2005) 89-92.
- [8] Shackelford, A. K., S. Y. Leong and K. F. Lee, “Small size probe fed notched patch antenna with shorting post. *Microwave Optical Technol Lett*, 31 (2001), 377-379.
- [9] H. Wang, X. B. Huang, D. G. Fang, and G. B. Han, “A microstrip antenna array formed by microstrip line fed tooth-like-slot patches,”*IEEE Trans. Antennas Propag.*, 55 (2007) 1210-1214.
- [10] Y. Sung, “A printed wide-slot antenna with a modified L-shaped microstrip line for wideband applications,” *IEEE Trans Antennas Propag.* 59(2011)3918-3923.
- [11] Ashish Singh, Mohammad Aneesh, Kumari Kamakshi, Anurag Mishra and J. A. Ansari, “Analysis of F-shape microstrip line fed dualband antenna for WLAN applications,” *Wireless network*, , Vol. 20, Issue 1, pp 133-140, January 2014.
- [12] Y. Sung, “Bandwidth enhancement of a microstrip line-fed printed wide-slot antenna with a parasitic center patch,” *IEEE Trans. Antennas Propag.*, 60(2012)1712-1217.
- [13] Mohammad Aneesh, Jamshed A. Ansari, Ashish Singh, Kamakshi, and Saiyed S. Sayeed, “Analysis of Microstrip Line Feed Slot Loaded Patch Antenna Using Artificial Neural Network,” *Progress In Electromagnetics Research B*, Vol. 58, 35-46, 2014.
- [14] Y.-W. Jang, “Broadband T-shaped microstrip-fed U-slot coupled patch antenna,” *Electronics Lett.*, 38(2002)496-498.
- [15] Ying Hu, David R. Jackson, Jeffery T. Williams, Stuart A. Long, and Varada Rajan Komanduri, “Characterization of the input impedance of the inset-fed rectangular microstrip antenna,” *IEEE Trans. Antennas Propag.*, 56(2008)3314-3319.
- [16] N. Mohammadian, M.-N. Azarmanesh and S. Soltani, “Compact ultra-wideband slot antenna fed

- by coplanar waveguide and microstrip line with triple-band-notched frequency function," *IET Microw. Antennas Propag.*, 4(2010)1811–1817.
- [17] M. S. R. Mohd Shah et. al., "Dual polarization inset-fed microstrip patch antenna," 8th Int. Conf. on ITS Telecommunications, 2008-ITST, Oct.2008, pp.29 – 32.
 - [18] Wen-Shyang Chen, Kin-Lu Wong, and Chun-Kun Wu, "Inset microstripline-fed circularly polarized microstrip antennas," *IEEE Trans. Antennas Propag.*, 48(2000)1253-1254.
 - [19] James O. McSpadden, Lu Fan, and Kai Chang, "Inset-Fed Ku-Band Circular Patch Antennas," *IEEE Antennas Propag. Society Int. Symp.*, 4(1999)2454-2458.
 - [20] Hua-Ming Chen, Yang-Kai Wang, Yi-Fang Lin, Che-Yen Lin, and Shan-Cheng Pan, "Microstrip-fed circularly polarized square-ring patch antenna for GPS applications," *IEEE Trans Antennas Propag.*, 57(2009)1264- 1268.
 - [21] Zhang Ronghui, Tang Xiaohong, Wang Ling, and Zhang Xianjing, "Study of Microstrip-Line Inset-Fed and Two-Layer Electromagnetically Coupled Rectangular Patch Antennas," *Asia-Pacific Conf. Proceeding On Microwave Conf.*, APMC 2005, 4(2005).
 - [22] J.-X. Niu, "Dual-band dual-mode patch antenna based on resonant-type metamaterial transmission line," *Electronics Lett.*, 46 (2010), 266-268.
 - [23] I.J. Bahal and P.Bartia, *Microstrip patch antenna*, Artech House, 1980.
 - [24] G. Kumar, and K.P. Ray, *Broadband Microstrip Antenna*, USA, Artech House, 2003.
 - [25] M. Meada, Analysis of gap in microstrip transmission line, *IEEE Trans. Antennas propag.*, 32(1972)1375-1379.
 - [26] Zhang, X. X. and F. Yang, "Study of slit cut microstrip antenna and its application," *Microwave Opt. Technol. Lett.*, 18(1998)297-300.
 - [27] Bahal, I. J., *Lumped Elements for RF and Microwave Circuits*, Artech House, Boston, 2003.
 - [28] Zeland, IE3D simulation software, Version 14.05, Zeland Inc., USA, 2008.