

# An Approach for Damping Low-Frequency Oscillations by Conventional and Fuzzy Logic Controller Power System Stabilizers

Atef A. El Amary, Hussein. A. Attia, Magdy A.S. Aboelela  
Cairo University, Faculty of Engineering,  
Electrical Power and Machine Dept. Cairo University, Egypt.

**atef\_emarkary@yahoo.com**

**Abstract** – Dynamic stability problems due to low frequency oscillations in power systems are a major concern for electrical engineers. These low frequency oscillations occur in the system because of the change in operating conditions due to the variation in load demand, generation level and line switching. Low-frequency oscillations are detrimental to the goals of maximum power transfer and optimal power system security. A contemporary solution to this problem is the addition of power system stabilizers (PSSs) to the automatic voltage regulators (AVRs) on the generators excitation system. The damping provided by this additional stabilizer provides the means to enhance the damping during low frequency oscillations. reduce the inhibiting effects of the oscillations. This paper presents a new technique utilizing fuzzy logic controller (FLC) power system stabilizer (PSS) for stability enhancement of a single machine real power system of Egypt. In order to accomplish the stability enhancement, speed deviation and acceleration of the rotor of synchronous generator were taken as the input to the fuzzy logic controller. These variables take significant effects on damping of the generator shaft mechanical oscillations. The stabilizing signals were computed using the fuzzy membership functions depending on these variables. The performance of the fuzzy PSS is compared with the conventional power system stabilizer (CPSS). The simulations were tested under different operating conditions. The simulation results are quite encouraging and satisfactory.

**Keywords:** Power System Stabilizer, Stability, Single Machine System, Matlab/Simulink, Fuzzy Logic, Fuzzy Set Theory, Generator Dynamic Modeling.

## 1. Introduction

Low-frequency oscillations, related to the small-signal stability of a power system, are detrimental to the goals of maximum power transfer and power system security.

These low frequency oscillations occur in the system because of the change in operating conditions due to the variation in load demand, generation level and line switching. Such small perturbations that are continually taking place will excite the system into a natural mode of oscillations of the order of 0.1 to 3.0 Hz [8,10,12]. If no damping is available, these oscillations may be sustained for minutes and grow to cause the system separation thereby affecting system security and also power transfer capability.

Power system stabilizers (PSSs) provide a cost effective and satisfactory solution to the problem of dynamic instability. PSSs are supplementary controllers in generator excitation systems, which receive a feedback signal from shaft speed, system frequency or accelerating power, and inject

**magdysafaa@yahoo.com**

stabilizing signal on the normal voltage error signal. Conventional PSSs employed by the utility are mostly lead-lag stabilizers using the speed as the input. These are designed based on the linear control theory, and the parameters of the PSS are determined so as to provide optimal performance at this particular operating point.

Conventional stabilizers for fixed structure and constant parameters are tuned for one operating point and can give optimal performance for that condition. General problems associated with the use of PSS, are:

- i) As the characteristics of the power system elements are non-linear, conventional stabilizers are not capable of providing optimal performance for all operating conditions.
- ii) The tuning of the PSS for a wide range of operating conditions.
- iii) The performance of the PSS under fault conditions.

Developments in digital technology have made it feasible to develop and implement improved controllers based on modern, more sophisticated techniques. Fuzzy logic-based PSS shows great potential in [1-7, 13-16]:

- i. Increasing the damping of generator oscillations.
- ii. Adjusting PSS parameters according to the plant environment (self tuning).
- iii. Providing good damping over a wide range of operating condition.
- iv. Eliminating the need for an explicit mathematical model of the system dynamics.
- v. Overcome systems ambiguities and parameters variations by modeling the control objectives in terms of a human operator's response to various system scenarios.

The fuzzy PSS relates significant and observable variables such as generator speed and its rate of variation, to an auxiliary control signal for the exciter using fuzzy membership functions (MF's). Designing PSS's based on fuzzy logic control has been an active research area and satisfactory results have been achieved.

## 2. System Description

Figure 1 show the one-machine connected to an infinite bus-bar for load frequency oscillation studies without PSS. A power system consist of a synchronous generator (SG), an armature current  $i$ ,

a terminal voltage  $V_t$ , an infinite-bus voltage  $V_o$ , a series transmission impedance  $Z$ , and a shunt load admittance  $Y$  [8].

A single machine infinite bus (SMIB) system with synchronous generator provided with IEEE type-ST1 static excitation system is considered [8]. A linear model of power system is shown in Figure 2. There are two major loops in this figure, the mechanical loop on top and the electrical loop at the bottom. The mechanical loop equations are linearized. The linearized equations are used because we are dealing with periodic small oscillations. The incremental torque ( $\Delta T_m - \Delta T_e$ ) is considered as the input and the torque angle  $\Delta\delta$  as the output.

The mechanical loop has two transfer function blocks from left to right. The first block is based on the equation of torque equilibrium, and the second block shows the relation of the angle and speed for the units chosen. In these blocks,  $M$  is the inertia constant,  $D$  the mechanical damping coefficient. The electrical loop in figure 2 has a supplementary control  $u_{pss}$  minus the incremental terminal voltage  $\Delta V_t$  as the input and the incremental internal voltage  $\Delta E'_q$  as the output, which is multiplied by

$K_2$  to become part of the electric torque  $\Delta T_e$  of the system. It has two transfer function blocks from right to left. The first block represents an exciter and voltage regulator system of the fast-response type with a time constant  $T_A$  and an overall gain  $K_A$ . This block should be expanded when the system has rotating exciter and voltage regulator. The second block represents the transfer function of the field circuit as affected by the armature reaction, with an effective time constant  $T_{do}'$  and a gain  $K_3$ . Finally,  $\Delta V_t$  consists of two components,  $K_5\Delta\delta$  due to the torque angle variation  $\Delta\delta$  and  $K_6$  due to the internal voltage variation  $\Delta E'_q$ . Here  $\Delta V_t$  means ( $V_{ref} - V_t$ ) and a negative sign is given to  $\Delta V_t$  because of the negative feedback. System constants  $K_1$  to  $K_6$  and initial conditions are derived in reference 8

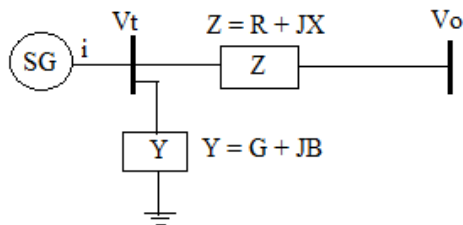

Figure 1: A one-machine infinite-bus power system

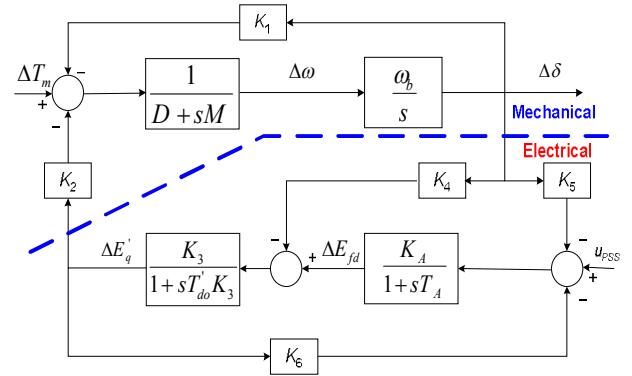

Figure 2: Block diagram of system model.

### 3. System Dynamic Model

The state space equation of the one-machine connected to an infinite-bus bar through a transmission line shown in Figure 2 is given by:

$$\dot{X} = AX + Bu_{pss} \quad (1)$$

Here, the state vector  $X$ ,  $A$  and  $B$  constant matrices are given as

$$X = \begin{bmatrix} \Delta\delta & \Delta\omega & \Delta E'_q & \Delta E_{fd} \end{bmatrix}^T, \quad A = \begin{bmatrix} 0 & \omega_b & 0 & 0 \\ -K_1/M & -D/M & -K_2/M & 0 \\ -K_4/T_{do}' & 0 & -1/K_3 T_{do}' & 1/T_{do}' \\ -K_A K_5/T_A & 0 & -K_A K_6/T_A & -1/T_A \end{bmatrix}$$

$$\text{and } B = \begin{bmatrix} 0 & 0 & 0 & K_A/T_A \end{bmatrix}^T$$

Where  $(\cdot)^T$  means the vector transpose of  $(\cdot)$ .

### 4. Synchronous Machine oscillation

Synchronous machine oscillations often exhibit themselves as falling into one of four categories:

- i. Local oscillations mode (frequencies are typically in the range of 1.0 to 2.0 Hz)
- ii. inter-area oscillations (frequencies are typically in the range 0.1 to 0.7 Hz)
- iii. inter-unit oscillations (frequencies are typically in the range 1.5 to 3 Hz)
- iv. Torsional oscillations (frequencies are 15 Hz for 2 poles and 8 Hz for 4 poles)

While change of rotor angle in a single machine is of concern, a possibly more important concern is the behavior of all the machines close connected to a system. It is desirable to have all the rotor angles moving the same relative direction over time during a system transient. The focus is on the difference in rotor angle between machines.

### 5. Conventional Power System Stabilizer (CPSS)

This section presents a conventional power system stabilizer (CPSS) structure, control, modeling, design and parameter tuning [8-10,12].

#### 5.1 PSS Objective:

The PSS is designed to introduce an electrical torque in phase with the rotor speed variations (damping torque). This is achieved by a

supplementary stabilizing signal  $u_{pss}$  applied to the automatic voltage regulator (AVR) of the generator as shown in Figure 3. This Figure also exemplifies the PSS basic structure to promote phase compensation to the phase lag introduced by generator, excitation system and transmission system.

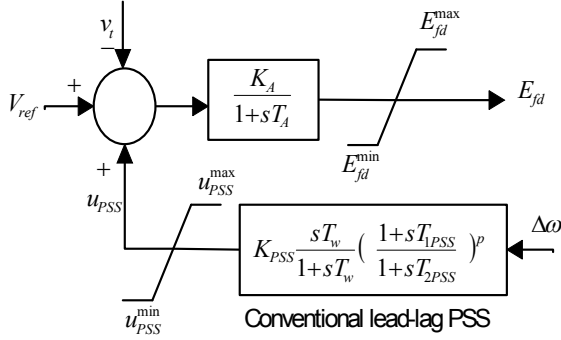

Figure 3: PSS Basic Structure and Supplementary Signal

### 5.2 PSS Input Signals

Various input signals can be used for PSS design. The common used signals are:

- Speed deviation  $\Delta\omega$
- Frequency deviation  $\Delta f$
- Electric power deviation  $\Delta P_e$
- Accelerating power  $\Delta P_a$

### 5.3 CPSS Structure

As shown in the Figure 3, basically, this controller is composed of a static gain  $K_{pss}$  which is adjusted to obtain the desired damping for unstable or poorly damped modes; a washout block is defined by the time constant  $T_w$  (in the range of 1 to 20 seconds), it works as a filter for low-frequencies (0.8 to 2.0 Hz); the time constants  $T_1$  and  $T_2$  define lead-lag of the input signal. Various structures of PSS can be implemented.

### 6. Desired Damping to Attenuate low frequency Oscillations

The linearized torque equation, dealing with small oscillations, takes the following form:

$$M \Delta \dot{\omega} = \Delta T_m - \Delta T_e - \Delta T_D \quad (2)$$

To derive an extra damping  $\Delta T_e$  through supplementary excitation,  $\Delta T_e$  must be in phase with  $\Delta\omega$  according to equation 2 and Figure 4. Similarly, an extra damping through the governor control must be in phase with  $\Delta\omega$ . Let the extra electric damping  $\Delta T_e$  and the extra mechanical damping  $\Delta T_m$  are given by:

$$\Delta T_m = -D_M \Delta\omega, \quad \Delta T_e = D_E \Delta\omega \quad (3)$$

From Eqns. 2 and 3 the characteristic equation of mechanical torque take the following form

$$Ms^2 + (D_M + D_E + D)s + \omega_b K_1 = 0 \quad (4)$$

The roots of equation 4 are given by:

$$s = \left( -\zeta_n \pm j\sqrt{1 - \zeta_n^2} \right) \omega_n$$

Where:  $\omega_n = \sqrt{\omega_b K_1 / M}$ , and

$$\zeta_n = (D_M + D_E + D) / (2\omega_b M)$$

and  $\omega_n$  is the un-damped mechanical mode oscillating frequency in radians per second for  $\zeta_n = 0$ , and  $\zeta_n$  is the damping coefficient in per unit. The characteristics equation of equation 4 gives a clear idea of the magnitude and degree of damping.

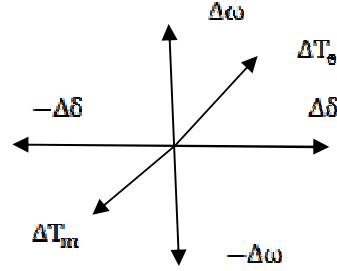

Figure 4: Torque phasors on the  $\Delta\delta - \Delta\omega$  phase plane.

### 6.1 Supplementary Excitation Control Design

The PSS may be designed from

- The un-damped natural mechanical mode frequency  $j\omega_n$ , or from
- The complex frequency  $\sigma + j\omega$  of the mechanical mode obtained from system eigenvalue analysis.

#### 6.1.1 The $j\omega_n$ , design first

Let  $\Delta\omega$  be the control input. A general design procedure may be outlined as follows.

#### a) Find $\omega_n$ from the Mechanical Loop

Neglecting all damping, the characteristic equation of the mechanical loop may be written as:  $Ms^2 + \omega_b K_1$ , and the solution are:

$$s = \pm j\omega_n, \quad \omega_n = \sqrt{\omega_b K_1 / M}$$

#### b) Find the phase Lag $\angle G_E$ between $u_{pss}$ and $E_q'$ of the Electrical Loop

The transfer function between  $u_{pss}$  and  $\Delta E_q'$  of Figure 2, including the feedback effect of  $K_6$  is

$$G_E = \frac{K_A K_3}{(1 + sT_A)(1 + sT_{do}' K_3) + K_A K_3 K_6} \quad (5)$$

at  $s = j\omega_n$  the phase lag is  $G_E = \angle G_E \Big|_{s=j\omega_n}$

#### c) Design a Phase Lead Compensation $\angle G_C$ for the Phase Lag $\angle G_E$

When  $\Delta\omega$  is chosen as the supplementary excitation input, we shall have

$$\angle G_C + \angle G_E = 0, \quad \angle G_E < 0$$

The phase lead compensation may be realized by operational amplifiers and the simplest transfer function may be chosen in the following form:

$$G_C = \left( \frac{1+sT_1}{1+sT_2} \right)^k, \quad k = 1 \text{ or } 2, \quad T_1 > T_2 \quad (6)$$

There is a phase angle limit that a compensation block can provide, and  $T_2$  cannot be too small. If  $T_2$  chosen as 0.2s and  $T_1$  as  $10 \cdot T_2$  the phase lead provided by each compensation block is about  $34^\circ$  for  $S=j2\pi$  rad/s corresponding to 1 Hz.

#### d) Design a Gain $K_C$ for the Supplementary Excitation

For this excitation control design,  $D_M$  and  $D$  of Eqn. 4 are neglected. A reasonable choice for the damping coefficient  $\xi_n$  of the normalized characteristic Eqn. 4 is about 0.1 to 0.3 per unit. The damping coefficient  $D_E$  is given by:

$$D_E \approx 2\xi_n \omega_n M \quad (7)$$

From Figure 2 and including the supplementary excitation, we also have

$$D_E = K_C K_2 |G_C|_{s=j\omega} |G_E|_{s=j\omega} \quad (8)$$

Therefore, from Eqns. 6 and 7 we get:

$$K_C = \frac{2\xi_n \omega_n M}{K_2 |G_C(j\omega_n)| |G_E(j\omega_n)|} \quad (9)$$

#### 6.2.1 Complex Frequency Design of Supplementary Excitation

Since the electrical loop of Figure 2 interacts with the mechanical loop, the supplementary excitation should probably be designed from the mechanical mode complex frequency based on eigenvalue analysis of the entire system, not just from  $j\omega_n$  of the mechanical loop alone. A procedure for complex frequency supplementary excitation design may be outlined as follows [8].

##### a) Find the Mechanical Mode Complex Frequency $\sigma + j\omega$ .

It can be found from an eigenvalue analysis of the entire system without  $u_{pss}$ .

##### b) Find the Phase Lag of $\angle G_E(\sigma + j\omega)$

Let the phase lag be,  $\angle G_E(\sigma + j\omega) \triangleq \gamma$ ,  $\gamma < 0$

##### c) Design a Phase Lead Compensation for $\angle G_E(\sigma + j\omega)$

From Eqn. 6 at  $k = 1$ , we get the following relation of phase angle [8]:

$$\angle(1+sT_1) = \angle(1+sT_2) - \gamma \quad (10)$$

$$\text{Let } \phi \triangleq \tan^{-1} \left[ \frac{\omega T_2}{1 + \sigma T_2} \right] \quad (11)$$

From Eqns. 10 and 11, we get

$$T_1 = \frac{\tan(\phi - \gamma)}{\omega - \sigma \tan(\phi - \gamma)} \quad (12)$$

##### d) Design an Adequate Damping Magnitude for the Mechanical.

Eqn. 7 is still valid but Eqns. 8 and 9 must be modified as follows:

$$D_E = K_C K_2 |G_C|_{s=\sigma+j\omega} |G_E|_{s=\sigma+j\omega} \quad (13)$$

$$\text{and } K_C = \frac{2\xi_n \omega_n M}{K_2 |G_C|_{s=\sigma+j\omega} |G_E|_{s=\sigma+j\omega}} \quad (14)$$

For the supplementary excitation design, an adequate  $\xi_n$  must be chosen. As stated earlier, only when the characteristic equation is in the normalized form can we have a clear idea of the magnitude and degree of damping.

#### 7. State Space equation of generator with CPSS

The state space equations of generator shown in Figure 2 occupied with CPSS shown in Figure 7 may be written as :

$$\dot{X} = AX + Bu_{pss} = A_C X \quad (15)$$

where  $B$  is the control matrix,  $u_{pss}$  the supplementary excitation, and  $A_c$  the controlled system matrix. The new state variable vector becomes

$$X = \left[ \Delta\omega, \Delta\delta, \Delta E'_q, \Delta E_{fd}, x_5, u_{pss} \right]^T \quad (16)$$

and the controlled system matrix becomes

$$[A_c] = \begin{bmatrix} A & \begin{matrix} 0 & 0 \\ 0 & 0 \\ 0 & 0 \\ 0 & K_A/T_A \end{matrix} \\ \begin{matrix} 0 & -K_1/M & -K_2/M & 0 & -1/T & 0 \\ 0 & -\frac{K_C K_1 T_1}{MT_2} & -\frac{K_C K_2 T_1}{MT_2} & 0 & \frac{K_C}{T_2} & -\frac{1}{T_2} \end{matrix} \end{bmatrix} \quad (17)$$

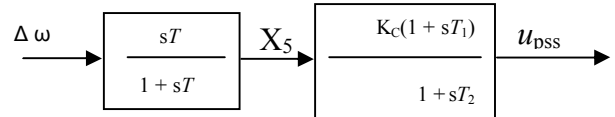

Figure 7: A supplementary excitation control

#### 8. Fuzzy logic Basic Power system Stabilizer

In the design of fuzzy-logic controllers, unlike most conventional methods, a mathematic model is not required to describe the system under study. It is based on the implementation of fuzzy logic technique to PSS to improve system damping.

Figure 8 shows the single machine connected to an infinite bus network through short transmission line occupied with PSS Fuzzy controller. The stabilizing signal output from PSS fuzzy controller is introduced in the excitation system.

##### 8.1 Fuzzy logic process

In contrast to a conventional PSS, which is designed in the frequency domain, a fuzzy logic PSS is being designed in the time domain. A fuzzy logic controller determines the operating condition from the measured values and selects the appropriate control actions using the rule base created from the expert knowledge.

Depending on the system state, the controller operates in the range between no control action and

full control action in a non-linear manner. The fuzzy controller in itself has no dynamic component, i.e. it can immediately perform the desired control action.

## 8.2 System Modeling

The schematic diagram of the complete system with the incorporation of the proposed power system stabilizer is shown in Figure 8. The optimal values of the PSS output for each operating point characterized by the input variables, angular

velocity ( $\Delta\omega$ ) and angular acceleration ( $\Delta\dot{\omega}$ )

Figure 9 shows the block diagram of fuzzy logic controller, it generally comprises four principle components: Fuzzification interface, knowledge base, decision making logic and defuzzification interface. If the output from the defuzzifier is not a control action for a process, then the system is a fuzzy logic decision system. The fuzzy controller itself is normally a two input and a single-output component.

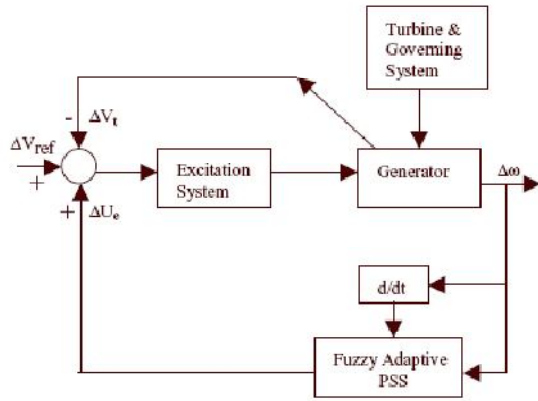

Figure 8: System with Fuzzy PSS

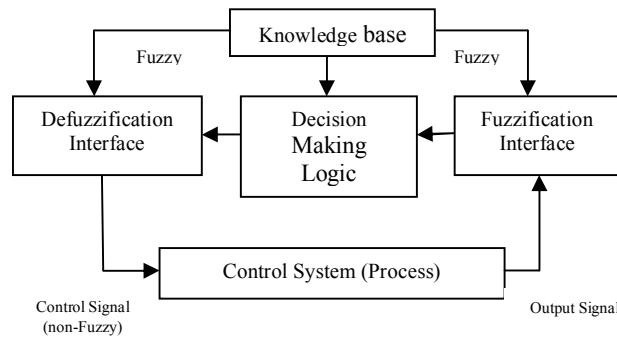

Figure 9: Principle Design of Fuzzy Logic

The first step in designing a fuzzy controller is to decide which state variables represent of system dynamic performance must be taken as the input signal to the controller. However, choosing the proper linguistic variables formulating the fuzzy control rules are very important factors in the performance of the fuzzy control system. System variables, which are usually used as the fuzzy controller inputs includes states error, state error derivative, state error integral or etc. In power system, based on previous experience. Generator

speed deviation ( $\Delta\omega$ ) and acceleration ( $\Delta\dot{\omega}$ ) are chosen to be the input signals of fuzzy PSS.

As it was mentioned earlier, if the synchronous generator automatic voltage regulator is utilized in a proper way it is capable of damping electromechanically oscillations of the generator shaft. The input to the excitation system would be The Control variable which is actually the output of fuzzy PSS. In practice, only shaft speed deviation is ready available. Hence, the acceleration signal can be derived from speed signals measured at two sampling instant by the following expression.

$$\Delta\omega(KT_s) = \frac{\Delta\omega(KT_s) - \Delta\omega((K-1)T_s)}{T_s}$$

where  $T_s$  is the sampling time. After choosing proper variables as input and output of fuzzy controller, it is required to decide on the linguistic variables. These variables transform the numerical values of the input of the fuzzy controller to fuzzy quantities. The number of these linguistic variables specifies the quality of the control which can be achieved using the fuzzy controller.

As the number of the linguistic variables increases, the computational time and required memory increase. Therefore, a compromise between the quality of control and computational time is needed to choose the number of linguistic variables. For the power system under study, five linguistic variables for each of the input and output variables are used to describe them, as in the following table

Table 1: The Linguistic Variables Used

LN	Large Negative
MN	Medium Negative
Z	Zero
MP	Medium Positive
LP	Large Positive

The two inputs; speed deviation and acceleration, result in 25 rules for each machine. Decision in table 2 shows the result of 25 rules, where a positive control signal is for the deceleration control and a negative signal is for acceleration control. The example of first rule is; rule 1: “if speed deviation is LP (large positive) AND acceleration is LN (large negative) THEN PSS output of fuzzy is Z (zero)”. The stabilizer output is obtained by applying a particular rule expressed in the form of membership function.

There are seven fuzzy levels (LN – large negative, MN - medium negative, SN - small negative, Z- zero, SP - small positive, MP - medium positive, LP - large positive). The membership functions for input and output variable are triangular. The min – max method inference engine is used; the defuzzification method used in this FLC is center of area. The complete set of control rules is shown in table 3.

Table 2: 25 Rules Decision table for PSS

Accel. →	LN	MN	Z	MP	LP
Speed dev. ↓					
LP	Z	Z	MP	MP	LP
MP	MN	Z	Z	MP	MP
Z	MN	Z	Z	Z	MP
MN	MN	MN	Z	Z	MP
LN	LN	MN	MN	Z	Z

Table 3: 49 Rules Decision table for PSS

$\Delta e/e$	LN	MN	SN	Z	SP	MP	LP
LN	LP	LP	LP	MP	MP	SP	Z
MN	LP	MP	MP	MP	SP	Z	SN
SN	LP	MP	SP	SP	Z	SN	MN
Z	MP	MP	SP	Z	SN	MN	MN
SP	MP	SP	Z	SN	SN	MN	LN
MP	SP	Z	SN	MN	MN	MN	LN
LP	Z	SN	MN	MN	LN	LN	LN

Each of the 49 control rules represents the desired controller response to a particular situation. The block diagram presented in figure 8 shows a FLC controller in the Matlab simulation (FIS editor) and in figure 9 the simulation of the surface control is presented [11,12].

There are different methods for finding the output in which Minimum-Maximum and Maximum Product Method are among the most important ones. Here the Minimum- Maximum method is used. Finally, the output membership function of the rule is calculated. This procedure is carried out or all of the rules and every rule an output membership function is obtained.

In addition, design of fuzzy logic controller can provide desirable both small signal and large signal dynamic performance at same time, which is not possible with linear control technique. Therefore, fuzzy logic controller has been potential ability to improve the robustness of the synchronous generator.

### 8. Case Study

#### 8.1 System Description and Problem Handling

In order to substantiate the validity of the introduced method in enhancing the damping during low frequency oscillations of a single machine power system and to clarify the encouraging obtained results, a real case study, Egypt network, "Marsa Matrouh Power station" was considered. The application has covered the following three scenarios:

- Marsa Matrouh at normal case (closed Sallum T.L.).
- Marsa Matrouh with open Sallum T.L.
- Marsa Matrouh with open Sallum T.L and Omit T.L.

The three scenarios application introduces the results considering the following three cases:

- System under low frequency oscillations without controller.
- System under low frequency oscillations with CPSS.

- System under low frequency oscillations with FLC.

Marsa Matrouh power station is connected with the Egyptian Network and is interconnected to Libya network through Sallum and Omit T.L.s. Figure 10 shows Marsa Matrouh power station single line diagram as a part of the network and the equivalent network is given in figure 11 [17]. All data of the original network are given in the same figure and the system data of equivalent network are given in appendix A.

The damping provided by this additional stabilizer provides the means to enhance the damping during low frequency oscillations. reduce the inhibiting effects of the oscillations. This paper presents a new technique utilizing fuzzy logic controller (FLC) power system stabilizer (PSS) for stability enhancement of a single machine power system. In order to accomplish the stability enhancement, speed deviation and acceleration of the rotor of synchronous generator were taken as the input to the fuzzy logic controller. These variables take significant effects on damping of the generator shaft mechanical oscillations. The stabilizing signals were computed using the fuzzy membership functions depending on these variables.

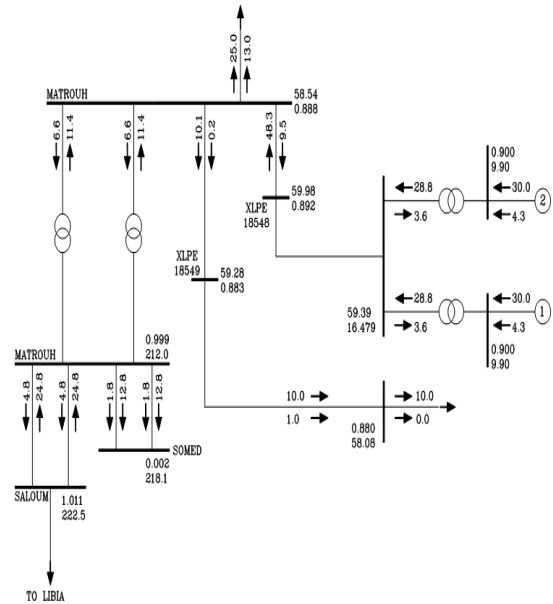

Figure 10: Marsa Matrouh power station single line diagram as a part of the Egyptian network

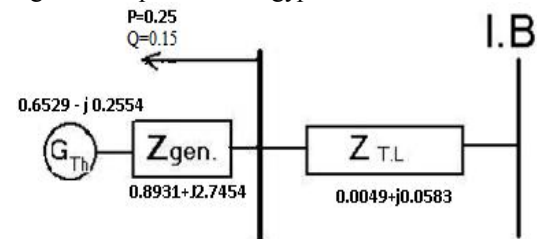

Figure 11: Equivalent network of Marsa Matrouh power station.

The performance of the fuzzy PSS is compared with the conventional power system stabilizer



(CPSS). The simulations were tested under different operating conditions. The simulation results are quite encouraging and satisfactory. In introducing the results of the three scenarios mentioned above the components parameters, the initial condition and PSS constants have been given only for the first scenario just for briefness. For the other scenarios, these parameters, conditions and constants were calculated utilizing the same procedure.

### 8.2 Results

A disturbance of 0.02 of speed ( $\omega$ ) was made, and the following response as shown the results of the machine shaft oscillations for the above three scenarios are given below.

#### Scenario a: Marsa Matrouh at normal case in existence of Libya interconnection (closed Sallum T.L.)

Figures 12, 13, and 14 show the machine shaft speed  $\omega$  and angle  $\delta$  oscillations without PSS, with lead PSS and with Fuzzy PSS for the this scenario. The following are the components parameters, the initial condition and PSS constants

#### Scenario b: Marsa Matrouh with open Sallum T.L.

Figures 15, 16 and 17 show the machine shaft speed  $\omega$  and angle  $\delta$  oscillations without PSS, with lead PSS and with Fuzzy PSS, respectively.

#### Scenario c: Marsa Matrouh with open Sallum T.L. and Omit T.L.

Figures 18, 19 and 20 show the machine shaft speed  $\omega$  and angle  $\delta$  oscillations without PSS, with lead PSS and with Fuzzy PSS for the three scenarios, respectively.

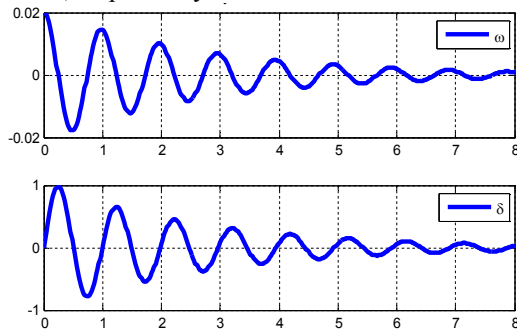

Figure 12: Scenario *a*, Case i: Machine  $\omega$  and  $\delta$  oscillations without PSS

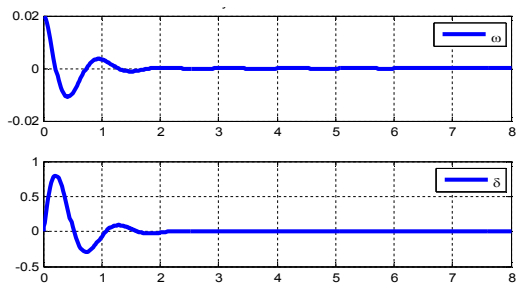

Figure 13: Scenario *a*, Case ii: Machine  $\omega$  and  $\delta$  oscillations with lead PSS

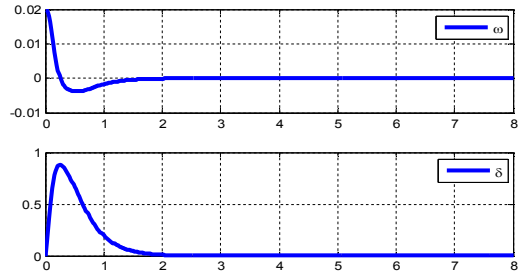

Figure 14: Scenario *a*, Case iii: Machine  $\omega$  and  $\delta$  oscillations with Fuzzy PSS.

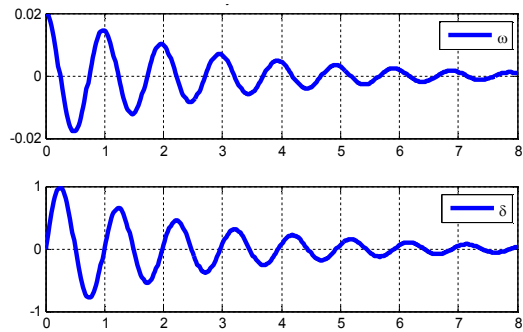

Figure 15: Scenario *b*, Case i: Machine  $\omega$  and  $\delta$  oscillations without PSS

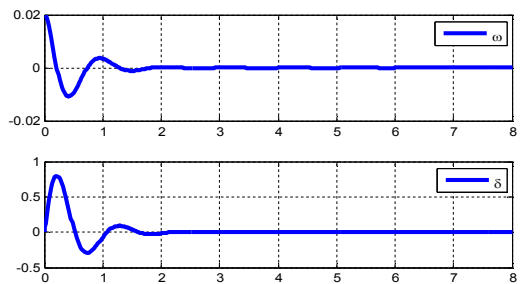

Figure 16: Scenario *b*, Case ii: Machine  $\omega$  and  $\delta$  oscillations with lead PSS

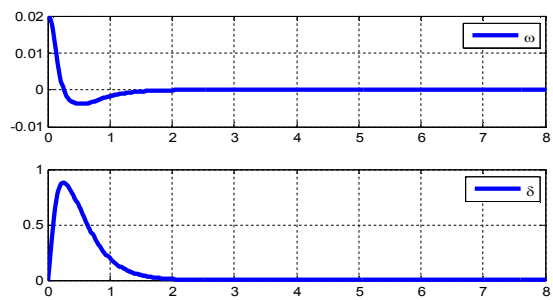

Figure 17: Scenario *b*, Case iii: Machine  $\omega$  and  $\delta$  oscillations with Fuzzy PSS

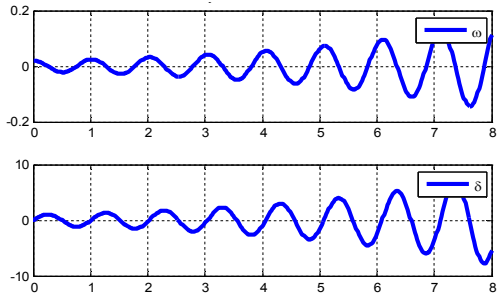

Figure 18: Scenario *c*, Case i: Machine  $\omega$  and  $\delta$  oscillations without PSS.

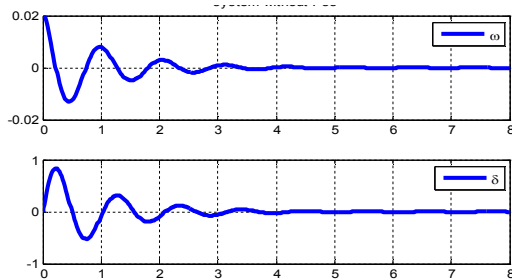

Figure 19: Scenario *c*, Case ii: Machine  $\omega$  and  $\delta$  oscillations with lead PSS.

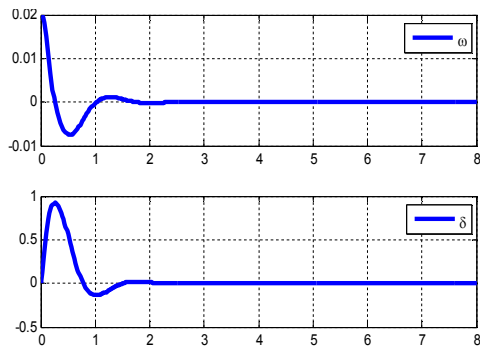

Figure 20: Scenario *c*, Case iii: Machine  $\omega$  and  $\delta$  oscillations with Fuzzy PSS

## 10. Conclusions

In this study the fuzzy logic power system stabilizer is designed for Single Machine and Power System. Speed deviation and acceleration of synchronous generator were taken as the input signals to the fuzzy logic controller. The performance of the power system with fuzzy logic power system stabilizer is better one since it is effective for all test conditions.

It was also shown in the simulation results that the fuzzy logic power system stabilizer can decrease both maximum overshoot and settling time the slip. The control signal, required, in all cases is with less magnitude

## REFERENCES

- [1] D. K. Sambariya, R. Gupta, and A. K. Sharma, "Fuzzy applications to single machine power system stabilizers" *Journal of Theoretical and Applied Information Technology*, Vol. 5, No. 3, 2009.

- [2] Ermanu A. Hakim, Adi Soeprijanto, Mauridhi HP, "PSS design based on PD and PI Fuzzy Controller by Particle Swarm Optimization", *Proceedings of the International Conference on Electrical Engineering and Informatics Institute Technology Bandung, Indonesia June 17-19, 2007*
- [3] H. U. P. Singh and Indraneel Sen, "A Novel Fuzzy Logic Based Power System Stabilizer for a Multimachine System" In: *Conference on Convergent Technologies for the Asia-Pacific Region: IEEE TENCON, Bangalore, India, Vol.3 1002-1006, , 15-17 October, 2003.*
- [4] N.Rajendran, R.Sreerama Kumar, A. Gunasekharan, and F.Gajendran, "Fuzzy Logic Based Adaptive Power System Stabilizer", *Proceedings of the International Conf. on Computational Intelligence, Robotics and Autonomous Systems (CIRAS 2003)*, 15-18 Dec. 2003, Singapore.
- [5] J. I. CORCAU , and E. STOENESCU, "An adaptive PID fuzzy controller for synchronous generator", *12<sup>th</sup> WSEAS International Conference on SYSTEMS, Heraklion, Greece, July 22-24, 2008*
- [6] E. A. Hakim, A. Soeprijanto, and Mauridhi H.P, "Fuzzy PID based PSS Design Using Genetic Algorithm", *International Journal of Electrical and Electronics Engineering* 4:5 2010.
- [7] D. A. Linkens, "A Neuro-Fuzzy Power System Stabiliser", *Proceeding of International Conference on Intelligent and Cognitive Systems*, September 1996, Tehran, Iran, pp. 106 -111.
- [8] Y. N. Yu , "Electric Power System Dynamics", Academic Press 1983.
- [9] H. Saadat, "Power System Analysis", McGrawHill, 1999.
- [10] G. F. Franklin. D. Powell. and A. Emami-Naeini, "Feedback Control of Dynamic Systems, 4<sup>th</sup> ed. Reading, MA: Addison-Wesley, 2002.
- [11] The MathWork.Inc. "Using MATLAB", 2011.
- [12] R. C. Dorf and R. H. Bishop, *Modern Control Systems*. 11<sup>th</sup> ed. Reading, MA, 2010.
- [13] S. Panda, and N. P. Padhy, "Matlab / Simulink Based Model of Single Machine Infinite-Bus with TCSC for Stability Studies and Tuning Employing GA", *Int. J. of Computer Science and Engineering*, Vol. 1, No.1, 2007, pp. 50-59.
- [14] S. Panda, N. P. Patidar, and R. Singh, "Simultaneous Tuning of SVC and Power System Stabilizer Employing Real- Coded Genetic Algorithm", *Int. J. of Electrical and Electronics Engineering*, Vol. 4, No. 4, 2009, pp. 240-247.
- [15] S. Panda, "Multi-objective PID Controller Tuning for a FACTS Based Damping Stabilizer Using Non-dominated Sorting Genetic Algorithm-II", *Int. J. of Electrical Power and Energy Systems*, Vol. 33, No. 7, September 2011, pp. 1296-1308.
- [16] S. Hameed, B. Das, and V. Pant, "Reduced Rule Base Self Tuning Fuzzy PI Controller for TCSC", *Int. J. of Electrical Power and Energy Systems*, Vol. 32, No. 9, November 2010, pp. 1005-1013.
- [17] A.A.Elemary, "Identification of coherent group for dynamic studies" Ph.D, 1987, Egypt

### Appendix A:

#### Component Parameters

All data are given in per unit of value, except that M and time constants are in seconds.

#### Generator Parameters:

$M=8.2$ ,  $T_{do}' = 4.91$ ,  $D = 0$ ,  $x_d = 0.5975$ ,  $x_d' = 5.875$ ,  $x_q = 5.625$

#### Excitation parameters:

$K_A = 200$ ,  $T_A = 0.05$

#### Line and load parameters:

$R = 0.0047$ ,  $X = 0.0738$ ,  $G = 0.25$ ,  $B = 0.15$

*Initial state:*  $P_{eo} = 0.67$ ,  $Q_{eo} = 0.21$ ,  $V_{eo} = 0.9$

#### PSS Constants

*PSS Based FUZZY Constants:*

$K_{11}=3.4805$   $K_{22}=4.1376$   $K_{33}=0.8925$

#### *PSS Based Lead Compensator:*

system phase=-1.3051

$\omega_n=6.6874$   $T_1=0.7418$   $T_2=0.0100$   $\theta=0.3000$

$K_c=0.9887$  PSS phase=1.3051