

Multiport DC-DC converters for renewable energy: an overview with contributions

Aruna Rajendran and Raja Jayamani

Adhiparasakthi Engineering College, Melmaruvathur, Tamilnadu, India

Email: arunarajendran2930@gmail.com, s.t.jayamani@gmail.com**Abstract**

The natural energy sources such as oil, coal, natural gas are finite. Also the environmental issues such as global warming have become increasingly serious and require attention. The applications of renewable energy (RE) sources viz. Solar, wind, biomass and tidal power as a major form of clean technology could be the right solution to solve energy crisis ahead with decreasing manufacturing cost. Power electronic converters are used to convert power from renewable sources to cater load demand and/or grid. Instead of using different DC-DC converters for connecting renewable sources and storage system to the load, Multiport DC-DC converter as single unit can be used to improve efficiency and power density. Many such converters have been proposed in recent times each of which has different topology, reliability and efficiency. The comparison of such different topologies is carried on in this paper which can assist proper selection of suitable topology for any specific requirement. Also, the research extension of the topologies is discussed quoting how the voltage gain can be improved and development of multiport DC-AC inverters.

Keywords: Renewable energy, Storage system, Integration, Multiport converters.

1.Introduction

Photovoltaic energy and wind energy systems have been developed vigorously over recent decade. The cost concerned is also expected to decrease in future along development of technology. A renewable energy source, if works alone cannot satisfy user's requirement of a stable reliable power supply. Hence, there is need of combining or integrating at least two complementary sources like Photovoltaic energy and wind energy along battery storage system leading to the terminology Hybrid Renewable Energy Generation System (HREGS).

For an area near power grid, a Grid connected Renewable Energy system is more appropriate option since the renewable energy sources can supply power both to the local loads and utility grid network, which is termed as Distributed Generation. Renewable Energy systems do not provide pure DC voltage for conversion into AC required by the grid. Hence there is need of a single stage DC-AC-DC conversion. Each source needs a single input DC-DC converter giving rise to a complicated system structure and relative high cost.

The renewable energy source is connected to load through traditional DC-DC converter [4-6] and the energy storage system is connected to either input port or output port through bidirectional DC-DC converter. This traditional solution is of low efficiency as it needs additional converter for energy storage system. Instead of individual converters for each of the renewable energy sources, single Multi-port bi-directional DC-DC converter forms the better choice. The Multiport DC -DC converter in turn is to be connected to an inverter to get the system connected to AC grid and load. The figure 1 depicts the block diagram of Multiport DC-DC Converter where P_{in} is the DC input power, P_b is the DC bidirectional power and P_o is the DC output power.

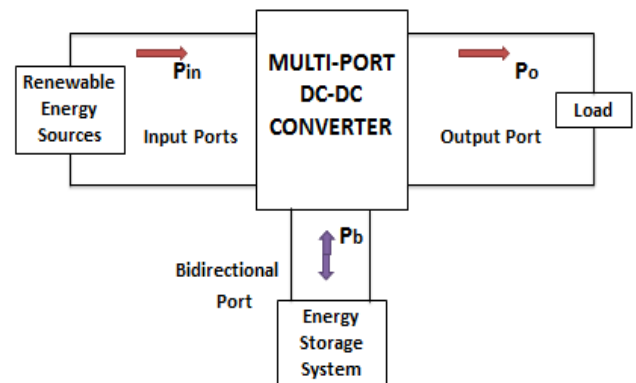

Figure 1 Renewable Energy System using Multiport DC-DC Converter

This paper provides review of Multiport DC-DC converters proposed by different research groups in recent years and compares their features in terms of number of components and reported efficiencies. Few further research areas are also discussed, including the potential application of DC-AC inverters. The organization of the paper is structured as follows: Section 2 presents the reported Multiport DC-DC converters falling under three categories. Section 3 provides brief vivid comparison of these converters and Section 4 puts forth some potential future research in the area. Section 5 concludes the paper.

2. Multiport DC-DC Converters

The Multiport DC-DC converters can be classified depending on connection among ports i.e., including or excluding the use of transformers. They can be broadly classified into three categories viz., Isolated multiport DC-AC-DC converters, Partly-Isolated multiport DC-DC converters and Non-Isolated multiport DC-DC converters. The various topologies of Multiport DC-DC converters were proposed by different researchers in recent years [1-3].

High-frequency transformer is used in Isolated Multiport DC-AC-DC Converter balances well the different voltage levels among different ports. The use of transformer leads to bulky converter and reduces overall power density. Transformer extends voltage conversion ratio but reduces efficiency of conversion. Power loss occurs due to leakage inductance. The number of components is very large since seldom shared. It can be operated with soft switching using appropriate control and modulation methods. The depiction is given in figure 2.

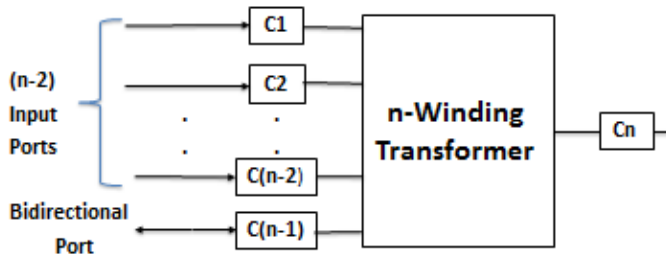

Figure 2 Isolated Multiport DC-AC-DC Converter

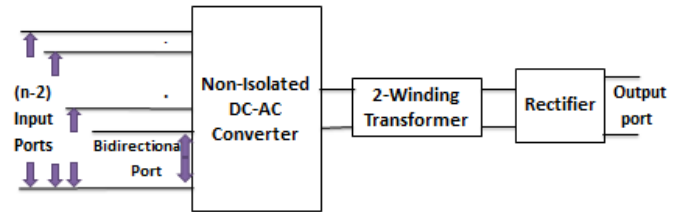

Figure 3 Partly-Isolated Multiport DC-DC Converter

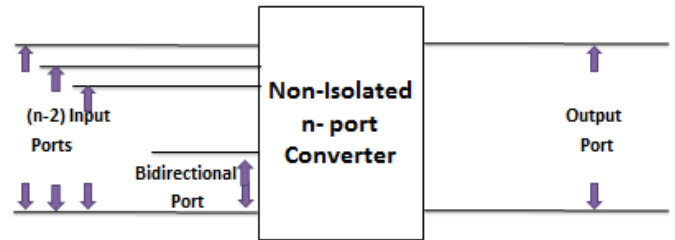

Figure 4 Non-Isolated Multiport DC-DC Converter

In the case of Partly-Isolated Multiport DC-DC Converter given by figure 3, high-frequency transformer is used to isolate one port from other common-grounded ports. Higher voltage gain can be obtained with a larger turns ratio of transformer. Energy storage system operates in all operating modes which can shorten lifespan of the energy system and lower the reliability of system. Disadvantages of having transformer in the circuit imply. The main advantage of Non-Isolated Multiport DC-DC Converter given by figure 4 is reduced number of components. Hence, it has compact structure. It is used only where galvanic isolation is not required. It has limited voltage gain since freedom of modulation of voltage conversion ratio is only the duty cycle. Coupled inductor can be used to extend voltage conversion ratio to overcome the issue of limited voltage gain. The features are small size and high power density.

2.1. Isolated Multiport DC-DC Converters

The power flow between any two of all ports of Isolated multiport DC-DC converter is realized through multi-winding high-frequency transformer. They have good galvanic isolation and each of the ports has its own components. They are mostly based on the traditional Full-Bridge or Half-Bridge converters or combination of both. The converters proposed in [7-14] have almost similar topology with a high-frequency transformer of three windings interfacing the three ports. An isolated converter formed with three-port triple half-bridge bidirectional DC-DC converter and three-winding high-frequency

transformer is proposed in [7] and that formed with Zero Voltage Switching (ZVS) three-port bidirectional DC-DC converter is studied in [8].

In multiport converters, one port may quit from the system leaving idle port at zero power. Optimal idling control strategy combining Phase-shift control with PWM control is proposed in paper [9]. A hybrid source system made of fuel cell and super capacitor utilizes an isolated three-port bidirectional full-bridge converter [10]. The figure 5 shows the three-port converter with three full bridges, two resonant tanks and three-winding transformer proposed in [11].

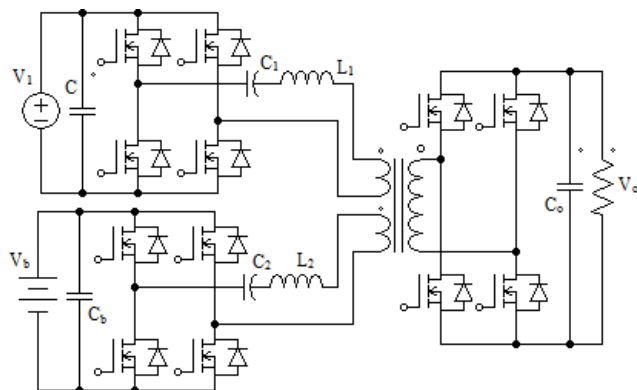

Figure 5 The converter topology in [11]

The converter in [12] has three half-bridges and a three-winding transformer in which bidirectional power flow happens by adjusting phase-shift angles of voltages across two sides of transformer. The analysis of three-port bidirectional converter in soft switching mode is done in [13]. Power switch losses of converters used in hybrid electric systems of [14] are analyzed. The paper [15] explains the topology and control of converter formed of three full-bridge cells and high-frequency transformer whereas a high-frequency magnetic coupled H bridge-double half-bridge three-port bidirectional converter applied in storage battery- ultra-capacitor hybrid energy storage system is explained in [16].

The converters in [17-19] have fuel cell as one of the sources. For safety reasons with galvanic isolation and a high voltage ratio, instead of going for non-isolated types comprising fuel cell, isolated type is considered in [17]. Another converter with current-fed switching topology

and multi-resonant circuits is in [18] as given in figure 6. The paper [19] introduces asymmetrical duty cycle control method for the bidirectional converter with two current-fed ports. Three-port converter in [20] based on Cuk topology uses only three power switches along single integrated magnetic core for inductors and windings as shown in figure 7.

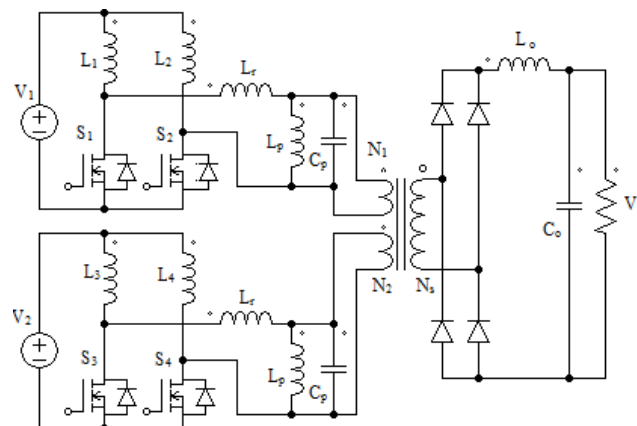

Figure 6 The converter topology in [18]

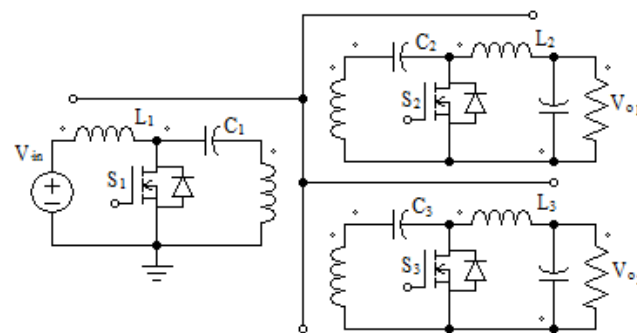

Figure 7 The converter topology in [20]

The converter in [21] uses only one controllable switch in each port. It is used for simultaneous maximum power point tracking control of hybrid system. Multi-input isolated three-level converter adopting high DC link voltage is proposed in [22].

The input inductors are operated in discontinuous conduction mode so that power can be shared between input sources through selection of input inductors. A solid-state transformer has been proposed in [23] to replace regular distribution transformer in future smart grid as depicted by figure 8.

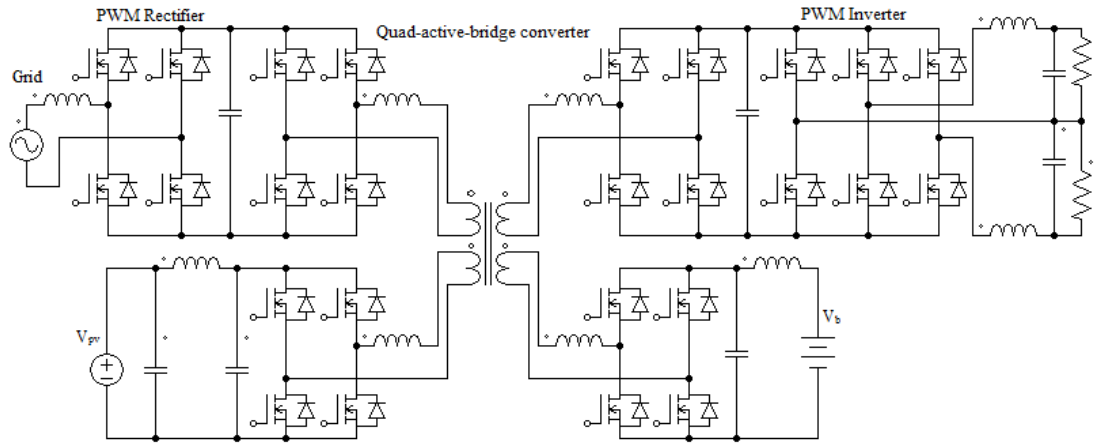

Figure 8 The converter topology in [23]

2.2. Partly-Isolated Multiport DC-DC Converters

Partly-Isolated converters have (n-1) of the n ports directly connected and then these are connected to the third port with galvanic isolation. Input and bidirectional ports are directly connected and are then connected to isolated output port. The paper [24] explains method for deriving soft-switching three-port converters and the circuit is as given by figure 9.

A dual-input interleaved Buck/Boost converter and its power flow control methods are discussed in [25]. A three-port converter in [26] is the integration of an interleaved bidirectional Buck/ Boost circuit and a full-bridge LLC resonant circuit for stand-alone PV/Battery system. The converter of [27] given by figure 10 uses least number of switches and soft-switching of main switch is realized by LCL resonant circuit.

A full-bridge three-port converter controlled by PWM plus Secondary-side phase-shift methods is proposed in [28]. A combination of conventional dual active bridge (DAB) and two bidirectional Buck/ Boost circuits is analysed in [30]. A converter involving hybrid battery and super-capacitor applications is given by [29] as depicted in figure 11.

A simple converter derived from full-bridge converter involving a coupled-inductor and diode rectifier is presented in [33]. The paper [34] provides on integrated three-port converter

satisfying the requirements of compact and efficient solution. The proposed converter of [35] uses only one switch-mode conversion stage. One port of the three-port converter in [36] is a current source port whose interleaved structure provides the desired small current ripple for the benefit of PV panel.

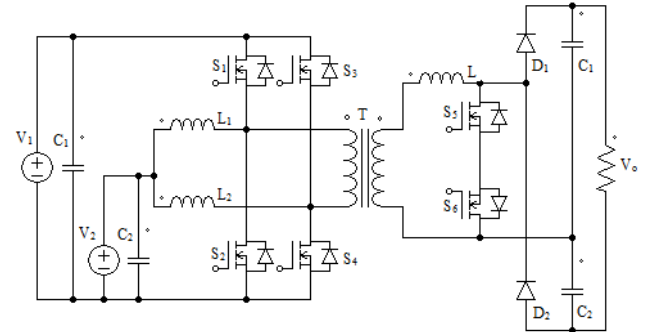

Figure 9 The converter topology in [24]

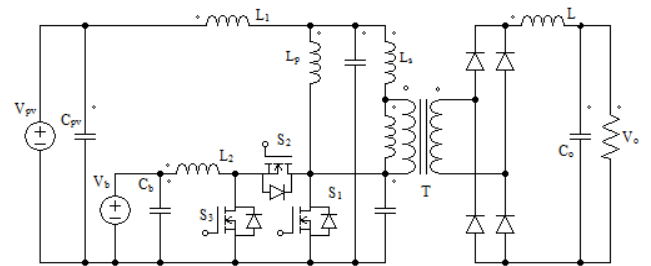

Figure 10 The converter topology in [27]

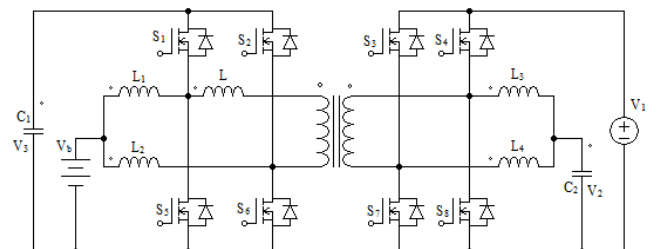

Figure 11 The converter topology in [29]

The paper [31] presents the method of deriving multiport converters from full-bridge converter and bidirectional converter through sharing of parasitized switching legs by both. A method for deriving three-port converters from full-bridge converter is explained in [32]. The schematic depiction of [31] and [32] are given by figures 12 and 13.

Operation of Current-fed dual active bridge converter is studied in [37]. Continuous input current of solar array can be maintained using a magnetic switch obtained from a fourth winding of half-bridge transformer of the converter circuit in [38] which is given by figure 14.

Three-port half-bridge converters are generated by the methods given by [39-40]. By adding two switches and two diodes to traditional half-bridge topology, the four-port converter is obtained in [41] which is shown in figure 15. The proposed three-port full-bridge converter in [42] is the integration of two buck-boost converters into primary side of full-bridge topology.

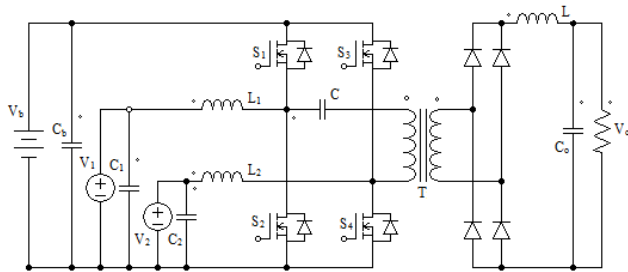

Figure 12 The converter topology in [31]

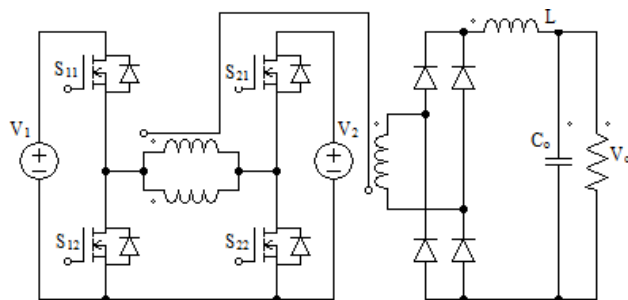

Figure 13 The converter topology in [32]

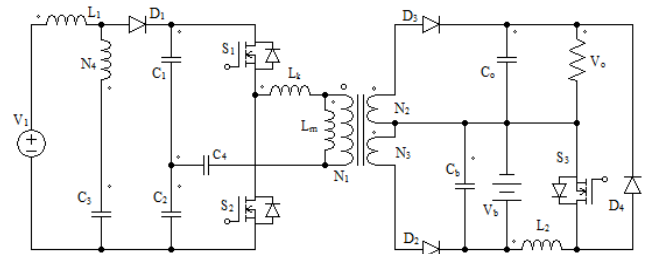

Figure 14 The converter topology in [38]

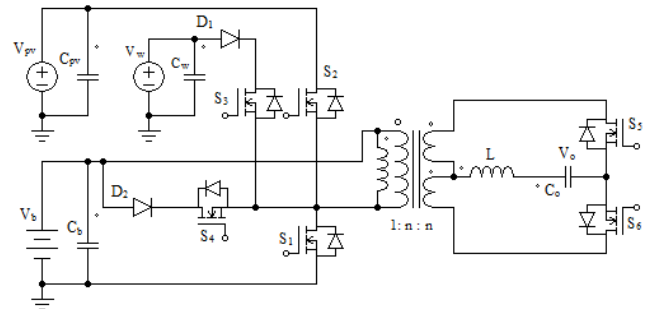

Figure 15 The converter topology in [41]

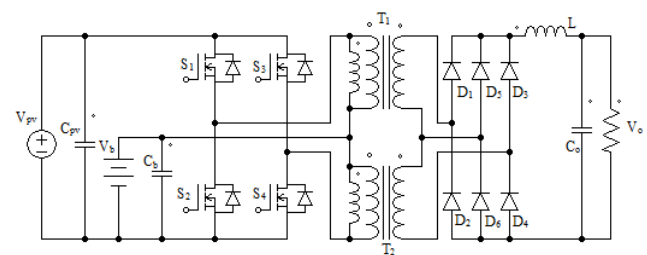

Figure 16 The converter topology in [43]

An interleaved half-bridge three-port converter [44] as an integration of two half-bridge three-port converter modules is presented in [43] as shown in figure 16.

2.3. Non-Isolated Multi-port DC-DC Converters

Non-Isolated multiport converters have been presented in literature with various control and modulation methods. Some use one inductor leading to small size while others use two or three. The gain of these is limited as they are derived from boost, buck and buck-boost converters. In order to cross this limitation, some converters use coupled-inductors to extend voltage conversion ratio. High-voltage gain converter is presented in [45] whose two input sources share only one inductor as shown in figure 17.

A multiport inverter based on DC-link Inductor (DLI) is proposed in [46]. A set of pulsating voltage source cells (PSVCs) are connected in series to derive the converter of [47]. A new three-port DC-DC high gain boost converter with bidirectional version of three-state switching cell for battery charging using PV modules in single conversion stage is presented in [48], the circuit of which is figure 18.

High-voltage gain and high efficiency converter based on coupled-inductor, intermediate capacitor and leakage energy recovery scheme handled in [50], is depicted by figure 19.

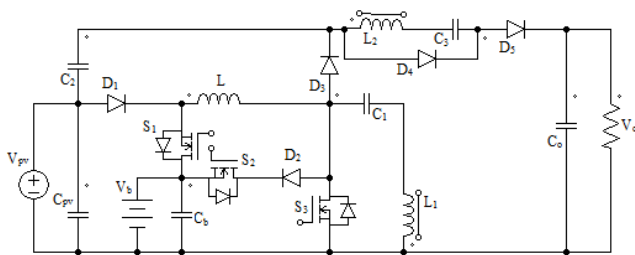

Figure 17 The converter topology in [45]

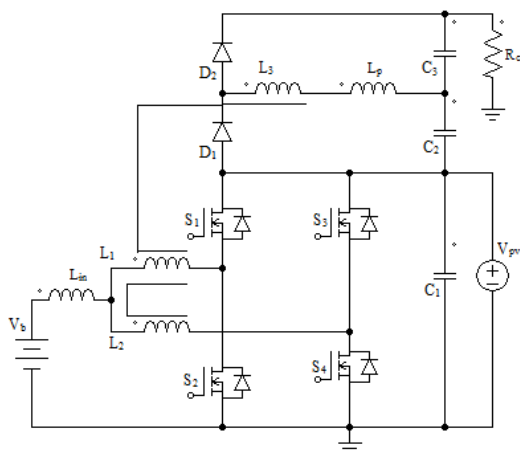

Figure 18 The converter topology in [48]

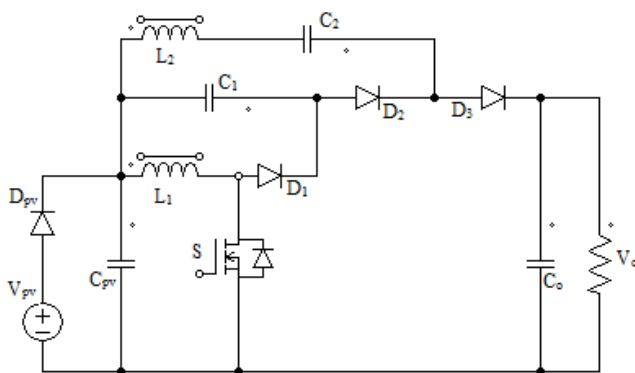

Figure 19 The converter topology in [50]

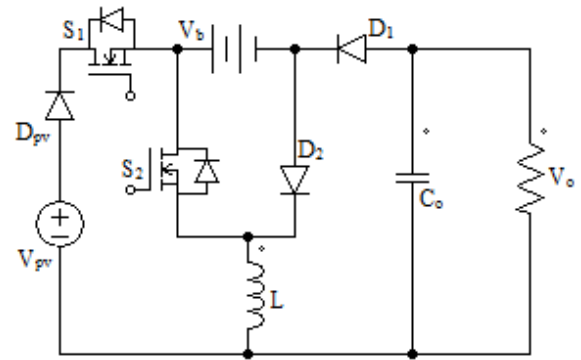

Figure 20 The converter topology in [52]

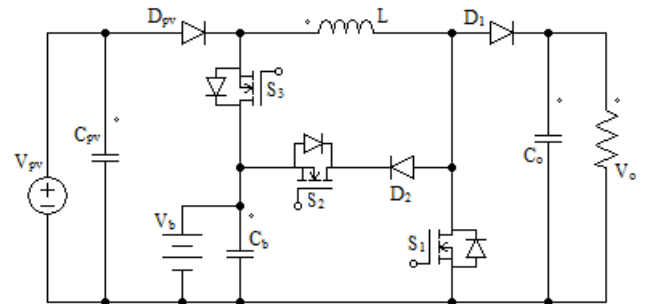

Figure 21 The converter topology in [54]

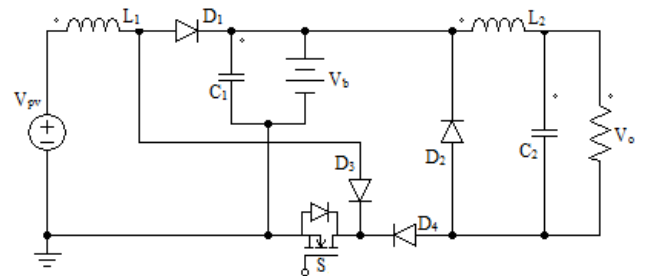

Figure 22 The converter topology in [55]

A simple topology is presented in [51]. A new family of three-port converters is proposed in [52] which is obtained by including a general cell into traditional buck, boost and buck-boost converters. The circuit is given in figure 20. Bifurcation analysis of multi-operating mode PV-Battery hybrid system is done in [53].

Systematic method for deriving topologies based on dual-input converters (DIC) and dual-output converters (DOC) is explained in [54]. One of the proposed circuits is presented by figure 21. Design of single-switch three-port converter for stand-alone PV system is proposed in [55] as shown in figure 22.

The paper [56] proposes a bidirectional non-isolated topology for hybrid systems to be used in electric vehicles. The converter in [57] utilizes only four switches independently controlled with four different duty ratios. A family of converters are formed in [58] as shown in figure 23 by introducing a bidirectional cell to basic converter topologies.

The topology of [59] has two sets of parallel boost converters which are controlled to produce two independent output voltage components. The multiport converter of [60] is obtained by interconnection of multiple bidirectional buck/ boost switching cells via DLIs which is depicted in figure 25.

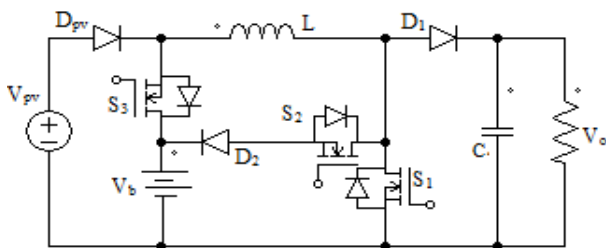

Figure 23 The converter topology in [58]

The converter presented in [61] has traditional buck-boost converters. A multi-input inverter for grid connected system is proposed in [62], which has buck/ buck-boost fused multi-input DC-DC converter and a full-bridge DC-AC inverter as given in figure 24. A converter derived from single inductor dual output converter is proposed in [63].

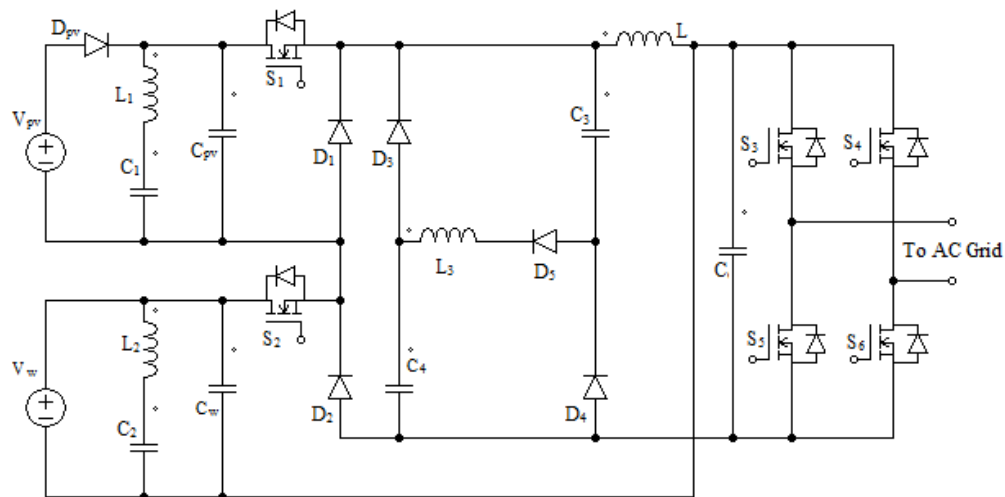

Figure 24 The converter topology in [62]

3. Comparison among the topologies

Many topologies have been proposed in recent times. They have different advantages and disadvantages. In order to provide certain guidance, a comparison is done regarding the structure and features of these topologies.

Isolated and Partly Isolated types provide galvanic isolation whereas the Non-Isolated ones don't provide this. High frequency transformer increases cost. More number of switches in these types leads to lower reliability [64,65].

Comparatively, Non-Isolated types are lower in cost and have less power switching devices along fewer components, but those with higher voltage gain are costlier because of coupled- inductors. These are suitable for small power applications.

The comparison is expressed in the form of tables 1-3 corresponding to Isolated Converters, Partly-Isolated Converters and Non-Isolated Converters respectively. The bar charts depicting the comparison of number of switches and efficiency of Isolated Converters, Partly-Isolated Converters and Non-Isolated Converters are also shown in figures 26-28 respectively.

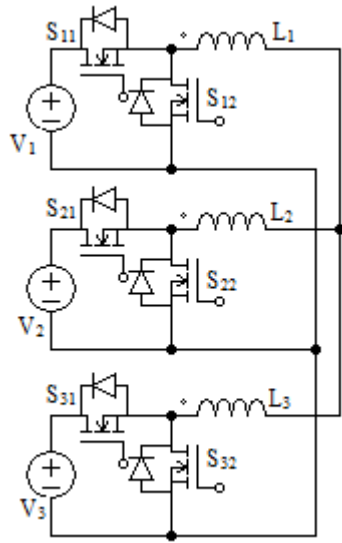

Figure 25 The converter topology in [60]

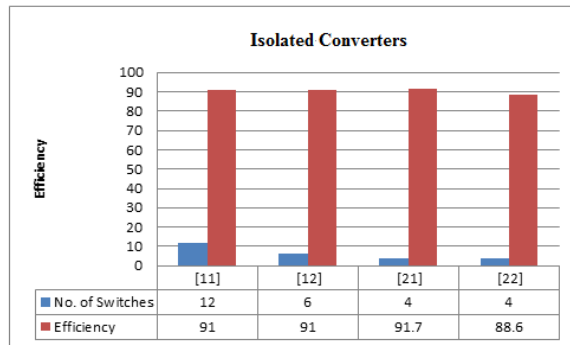

Figure 26 Comparison of number of switches and efficiency of Isolated Converters presented in papers [11], [12], [21] and [22]

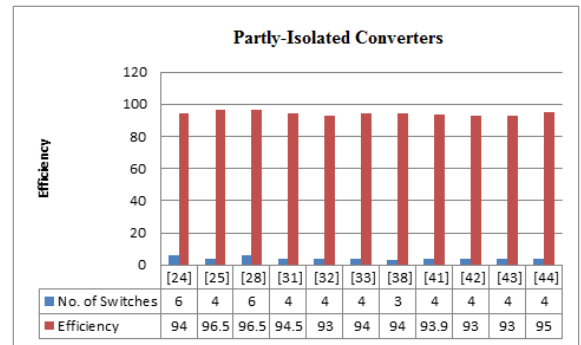

Figure 27 Comparison of number of switches and efficiency of Partly-Isolated Converters presented in papers [24-28], [31-33], [38] and [41-44]

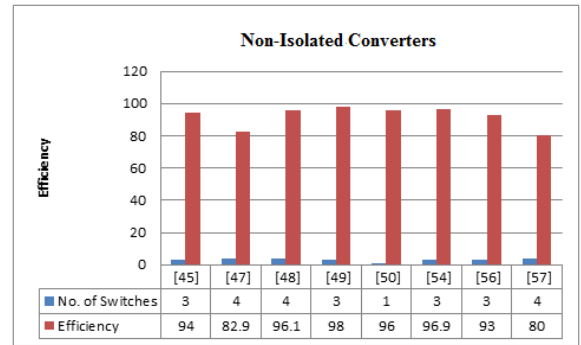

Figure 28 Comparison of number of switches and efficiency of Non-Isolated Converters presented in papers [45], [47-50], [54], [56] and [57]

Table 1 Comparison Table of Isolated Multiport Converters

Serial Number	Reference Number and Features	Number of				Capacity Reported	Maximum Efficiency	Features
		Switches	Diodes	Inductors	Windings of Transformer			
1	7	6	-	4	3	1kW	-	High Voltage conversion ratios; Galvanic isolation for all the ports
2	8	12	-	3	3	1kW	-	
3	9	12	-	3	3	1kW	-	
4	10	12	-	3	3	-	-	
5	11	12	-	3	3	500W	91%	
6	12	6	-	2	3	6kW	91%	
7	13	12	-	-	3	6kW	-	
8	14	12	-	2	3	-	-	
9	15	12	-	3	3	1.5kW	-	
10	16	6	-	3	3	5.7kW	-	
11	17	12	1	-	3	400W	-	
12	18	4	4	3	3	-	-	
13	19	6	-	3	3	2.5kW	-	
14	20	3	-	3	3	-	-	
15	21	m ports	m+4	m+1	2	43W	91.7%	
16	22	4	4	2	1	1.6kW	88.6%	
17	23	20	-	2	4	-	-	

Table 2 Comparison Table of Partly- Isolated Multiport Converters

Serial Number	Reference Number and Features	Number of				Capacity Reported	Maximum Efficiency	Features
		Switches	Diodes	Inductors	Windings of Transformer			
1	24	6	2	3	2	800W	94%	Combination of Interleaved bidirectional converter and Bridgeless Boost rectifier. High frequency transformer. Single stage power conversion. Voltage and power regulated.
2	25	4	4	3	2	1.5kW	96.5%	Total control of power flow from input ports to output ports
3	26	4	4	3	2	500W	-	ZVS realized. Low cost and reduced size. Since Full Bridge unit is shared, input current ripple small.
4	27	3	4	3	2	50W	-	ZVS and ZCS for main switches, Reduced number of switches
5	28	6	2	3	2	600W	96.5%	Improved power devices sharing. Single stage power conversion. Decoupled power control. ZVS realized. No circulating current at free-wheeling stage. Reduced conduction loss, Voltage stresses suppressed.

6	29	8	-	5	2	40W	-	ZVS realized. Current ripples reduced by Interleaved control.
7	30	6	-	2	2	300W	-	Minimised input current ripples, Bidirectional power flow, soft switching.
8	31	4	4	1	2	500W	94.5%	Combination of Full Bridge and Bidirectional converter. Simple topology. Voltage regulation and ZVS realized.
9	32	4	4	2	2	300W	93%	Two switching legs of Full Bridge converter are two switching cells and connected to different sources. ZVS realized. High conversion efficiency. Various similar topologies given.
10	33	4	4	-	2	180W	94%	ZVS realized. Operates over large voltage range.
11	34	5	1	-	3	200W	-	ZVS for all switches, tight load regulation.
12	35	3	1	-	3	60W	-	One switch mode conversion stage. Regulated output.
13	36	12	-	6	6	3kW	-	Three port three phase Interleaved bidirectional DC-DC converter. Voltage boost capability. Soft switching.

14	37	12	-	4	2	5kW	-	High efficiency, step up ratio. Wide input voltage range
15	38	3	4	2	4	500W	94%	ZCS for all main diodes and switches, continuous input current.
16	39	4	-	1	3	200W	-	Integration of Half Bridge converter and a Forward Flyback converter. ZVS realized.
17	40	4	1	-	3	120W	-	Simple topology, high integration, less no.of devices.
18	41	4	2	-	3	-	93.9%	Four ports. Adds two switches and two diodes to half Bridge topology. ZVS realized. Can be extended for additional source.
19	42	4	4	-	4	400W	93%	Single stage power conversion. High power density and efficiency.
20	43	4	6	1	4	500W	93%	Three-leg diode rectifier at Secondary side, hence improved power transfer capability. Extended voltage transfer ratio. Reduced conduction losses. Improved efficiency and high power density. All switches ZVS realized.
21	44	4	6	1	4	400W	95%	Version of two interleaved Half Bridge converter. Soft switching. High efficiency and power density.

Table 3 Comparison Table of Non-Isolated Multiport Converters

Serial Number	Reference Number and Features	Number of				Capacity Reported	Maximum Efficiency	Features
		Switches	Diodes	Inductors	Windings of Transformer			
1	45	3	5	2	NA	300W	94%	Reduced volume, High efficiency, voltage conversion ratio,
2	46	2	1	1	NA	1kW	-	Based on DC link Inductor. Generated by Pulsating Voltage cells(PVC). High efficiency,power density and reliability.
3	47	4	2	1	NA	-	82.9%	Series connection of PVCs. High reliability.
4	48	4	2	2	NA	500W	96.1%	High voltage gain, ZVS over wide range, High efficiency.
5	49	3	3	1	NA	140W	98%	High efficiency, power density, reliability, small size, low cost
6	50	1	3	1	NA	400W	96%	High voltage gain, efficiency.
7	51	3	3	2	NA	100W	-	Simple operation. Easy to control.
8	52	2	2	1	NA	-	-	Cost effective, Compact size
9	53	3	1	2	NA	240W	-	High voltage gain, efficiency.
10	54	3	2	1	NA	1kW	96.9%	High integration, efficiency and power density.
11	55	1	4	2	NA	-	-	Single switch. Reduced component size.

12	56	3	1	1	NA	1kW	93%	Active power sharing. Reduced element count.
13	57	4	4	2	NA	220W	80%	Less no.of inductors, low voltage batteries.
14	58	2	2	1	NA	1kW	96.9%	Good dynamic performance
15	59	4+n	N	2	NA	200W	91%	Minimum no. of switches. High voltage gain.
16	60	2n	-	3n	NA	1kW	98%	Bulky. DC link capacitor eliminated. Reduced size. Low cost.
17	61	1+n	1+n	1+n	NA	-	-	High voltage gain, Reduced semiconductor current stress.
18	62	6	5	1	NA	1kW	-	Large range of input voltage variation. MPPT for both PV and Wind.
19	63	3	3	1	NA	-	-	Compact size, cost efficient. All three ports common ground.

4. Future Research Direction

The applications of multiport DC-DC converters have led to issues like limitation of voltage conversion ratio of Non-Isolated multiport converters and the need of added inverter for AC applications. The following three research topics may be considered for future work.

4.1. Non-Isolated High voltage gain Multiport converters

For the Grid-connected renewable energy generation systems using multiport converters, the voltage conversion ratio, V_{out} / V_{in} needs to be high. Traditional Non-Isolated converters does not provide such high step-up gain. Hence, there is need to extend gain using coupled inductors, switched- capacitors, switched- inductors and voltage multiplier circuits.

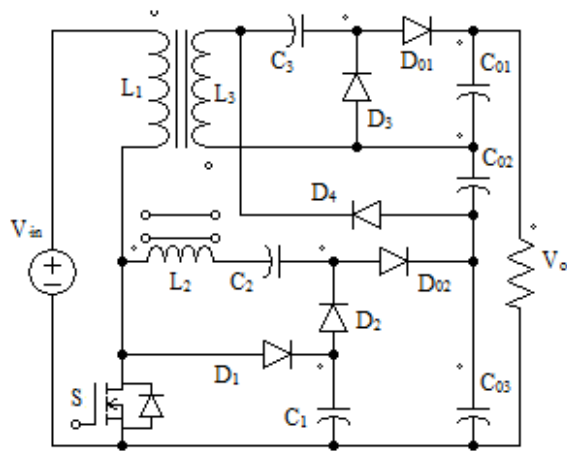

Figure 26 The converter topology in [66]

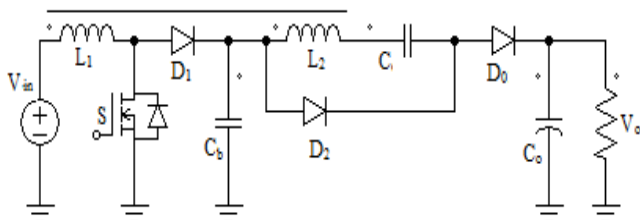

Figure 27 The converter topology in [67]

The utilization of coupled inductors is better than using transformers. The common technique of coupled-inductor circuit has been carried out by researchers in [45, 48, 63]. High step-up converter topologies are proposed with features such as coupled inductor in [66] and additional switched capacitor in [67], the circuits are presented in figures 26 and 27.

4.2. Multiport inverters

To convert power from renewable energy source and provide to the grid, there is a need of DC- AC conversion. This can be done in double stage or single stage configuration. In double stage connection, there are a DC-DC converter and an DC-AC inverter whereas single stage connection needs a DC-AC inverter.

The single stage connection has the benefit of having higher efficiency and a lower cost. Hence, the concept of Multiport converter can be improved as DC-AC Multiport inverter. The papers [68, 69] based on three-level neutral-point-clamped inverter and the circuit of [68] is given by figure 28.

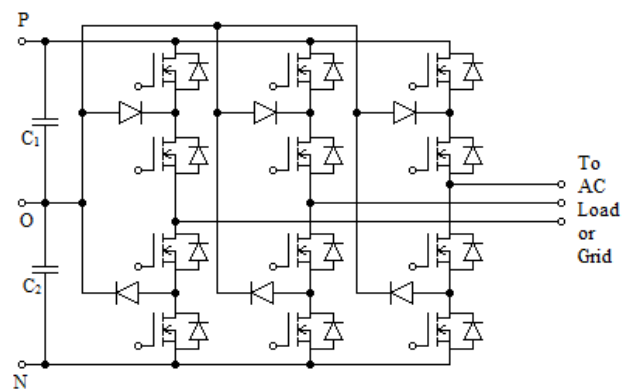

Figure 28 The converter topology in [68]

4.3 Z-source based Multiport inverters

Conventional pulse width modulation inverter needs an additional DC-DC converter to interface the battery and hence, to control state of charge (SoC). Due to the wide voltage range of power sources, the conventional Buck inverter imposes high stresses to the switching devices. DC-DC boosted inverters can suppress these stresses but at high cost and complexity. Both the Buck and Boost configurations use inverter bridge and one DC-DC converter atleast which in turn increases cost and system complexity reducing system reliability.

The Z-source inverter (ZSI) is attractive for the following reasons. ZSI has two independent control freedoms viz., Shoot-through duty cycle and Modulation index against the only control freedom of Modulation index in the case of the conventional PWM inverter. The two control freedoms provide the ability to produce any desired output voltage, regulate (SoC) and control output power/ voltage. The Single stage of ZSI is less complex and more cost effective. ZSI is more reliable as the momentary shoot-through can no longer destroy the inverter i.e., both devices of a phase leg can be On for a significant period of time. ZSI can be used by replacing one of the capacitors with a battery. These facts make the Z-source inverter highly desirable.

By taking advantage of the characteristics of Z-source impedance network such as two capacitors used as energy storage systems, it can be used to derive Multiport DC-AC inverters. Traditional Z-Source inverter as shown in Figure 29, provides both buck and boost operation. The impedance network consists of two inductors (L_1 and L_2) and two capacitors (C_1 and C_2) where it couples the main inverter circuit to the DC voltage source. ZSI can operate in boost inverter or buck inverter but not as buck-boost inverter[70].

Quasi-Z-Source Inverter (QZSI) is of new interest in engineering industry and research. Reduction in device rating being the main objective in introducing QZSI, it is feasible in a wide range for high power with medium voltage applications. Continuous input current Quasi-Z-

Source Inverter (QZSI) is derived from the original Z-Source Inverter (ZSI) where it can be utilized to all types of power converters.

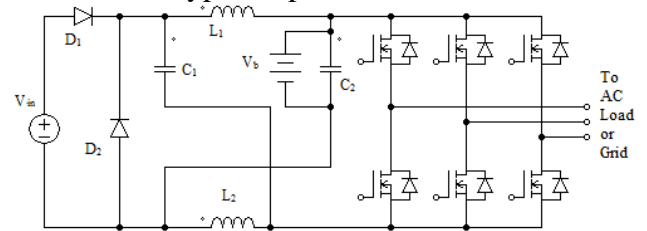

Figure 29 The converter topology in [70]

Some of the disadvantages in traditional ZSI can be overcome by the use of QZSI. The QZSI has the wide range of applicability in the renewable energy system, where it gives a single stage power conversion with buck-boost characteristics and improves the reliability of the inverter. In shoot through states, power switches in a leg are turned on at the same time and it is used to step up the voltage while the output voltage in QZSI can be boost to designed value.

Research based on these QZSI has concentrated on modelling and control, photovoltaic and other electrical applications. The QZSI can buck and boost the input voltage in single stage with two control variables; shoot through and modulation index. New topologies of QZSI derived from original ZSI can be proposed for PV applications, because of continuous input current and reduced capacitor rating. QZSI is combined with renewable energy system for a wide voltage range to distribute for power grid.

Moreover, the voltage stress on capacitors and current stress on inductors and diodes in QZSI are lower than traditional ZSI for same input and output voltage. QZSI avoids initial current inrush, due to which the destruction of the devices can be avoided. Also, these topologies, more viable for solar cell and fuel cell applications, may acquire high voltage gain to match the source voltage difference. For the same input and output voltages as in ZSI, QZSI can use lower duty cycle and higher modulation index, which results in less switching stresses, better output power and lower input current ripple.

The advantage of including inductors in the QZSI network will limit the current ripple through the devices during boost conversion

mode. The inverter draws current with minimal ripple from the Solar PV panel by reducing the size of filtering capacitors. QZSI produce the desired output voltage to the grid, regulate the battery state of charge and control the PV output power to maximize the energy production. An additional input filter can be avoided.

The Quasi Z-Source inverter topologies have one big advantage, such as the DC power supply and the inverter has the same ground connection. This facilitates the design of the driver circuits and current sensing. Also, EMI problems are decreased. QZSI also has added advantage such as higher modulation index with lower component voltage stress. QZSI is obtained from the basic framework of the ZSI. Hence QZSI can be used as a replacement for all the applications in which ZSI is used mainly because of the above mentioned advantages.

Connecting energy storage system to one of the two capacitors in Quasi Z-Source impedance network in parallel is presented in [71] and depicted by figure 30. Conventional structure needs to be oversized to allow wide PV voltage variation derived from changes of irradiation and temperature. The Quasi Z-Source inverter structure can deal such voltage variations without the need for overrating device. Also, shoot – through state helps in reduced component count and system cost along improved reliability. Lower component rating and reduced ripples are added advantages.

Considering more voltage gain, reduce in size of passive components, lesser harmonics and increase in efficiency of the QZSI, it is advantageous and can lead to lower cost when compared to conventional ZSI. Control and modulation techniques for the inverter in [71] are explained in [72-75]. The modified circuit is given in figure 31 [76].

Table 2 Comparison of the three types of inverters

Features/ Type of inverter	Traditional Buck/ Boost/ Buck- Boost converter based two- stage inverter (Figure 28)	Single stage Impedance Source (Z- Source) inverter (ZSI) (Figure 29)	Single stage Quasi Impedance Source (Z- Source) inverter (QZSI) (Figure 30 and 31)
Efficiency %	x	Almost x and in some cases less than x	Greater than x
Size	Not compact	Compact	Compact
No. of Components	Many	Less	Less
Voltage stress on switches	Low	Low	High
Total Harmonic Distortion (THD) %	y	Z less than y	Less than z
Capacitor rating	High	Lower than in Traditional one	Lower than in ZSI
Cost in units	m	n less than m	Less than n

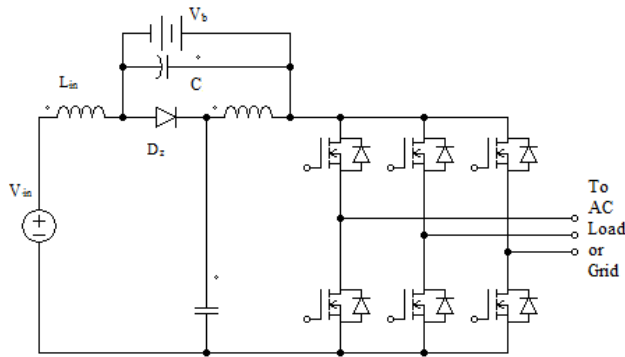

Figure 30 The converter topology in [71]

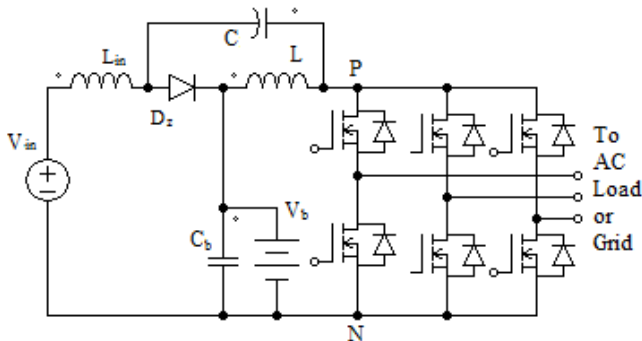

Figure 31 The converter topology in [76]

All of these Z-source based inverters are based on traditional two-level three phase inverter. Application of Z-source impedance network in other inverters such as neutral-point-clamped three-level inverter and single phase inverter can be researched further.

5. Conclusion

A literature review of various topologies used for multiport converters has been presented in the paper. The research in this area has gained substantial progress and also received more attention from researchers in the area of hybrid renewable energy and storage systems. The general working principles advantages and disadvantages of the different topologies are discussed. The comparison among the three kinds of converters has been done in order to pose as guide for practical applications. Conventional inverters, Z source inverters and Quasi Z source inverters are briefly analysed along respective models as well as the comparison is made among them. Further research is to be carried out to

increase the voltage of the converter and in the design of novel multiport DC-AC inverters.

REFERENCES

1. H. Tao, A. Kotsopoulos, J.L. Duarte and M.A.M. Hendrix, "Family of multiport bidirectional DC-DC converters" in IEE Proc.-Electr. Power Appl., Vol. 153, No. 3, May 2006, pp.451-458.
2. Haimin Tao, Jorge L. Duarte, and Marcel A.M. Hendrix, "Multiport Converters for Hybrid Power Sources", in Proc. IEEE Power Electronics Specialists Conference (PESC'08), Rhodes, pp.3412-3418.
3. Wuhua Li, Xiaodong Lv, Yan Deng, Jun Liu, Xiangning He, "A Review of Non-Isolated High Step-Up DC/DC Converters in Renewable Energy Applications", in APEC, 2009, pp.364-369.
4. Roberto F. Coelho, Filipe M. Concer, Denizar C. Martins, "A Simplified Analysis of DC-DC Converters Applied as Maximum Power Point Tracker in Photovoltaic Systems", in Proc. IEEE symposium on Power Electronics for Distributed Generation System, 2010, pp.29-34.
5. Bing Hu, Liuchen Chang, Yaosuo Xue, "Research on a Novel Buck-Boost Converter for Wind Turbine Systems", in Proc.ICSET 2008, pp.228-233.
6. Alberto Rodríguez Alonso, Javier Sebastian, Diego G. Lamar, Marta M. Hernando, Aitor Vazquez, "An overall study of a Dual Active Bridge for bidirectional DC/DC conversion", in ECCE 2010, pp.1129-1135.
7. Haimin Tao, Jorge L. Duarte and Marcel A. M. Hendrix, "Three-Port Triple-Half-Bridge Bidirectional Converter With Zero-Voltage Switching", IEEE Trans. on Power Electronics, Vol. 23 No.2, March 2008, pp.782-792
8. Haimin Tao, Andrew Kotsopoulos, Jorge L. Duarte and Marcel A. M. Hendrix, "Transformer-Coupled Multiport ZVS Bidirectional DC-DC Converter With Wide Input Range", IEEE Trans. on Power Electronics, Vol. 23 No.2, March 2008, pp. 771-781

9. Jiang Y., Liu F., Ruan X. and Wang L., “Optimal idling control strategy for three-port full-bridge converter”, in ECCEASIA 2014, pp.458 - 464.
10. Phattanasak M., Ghoachani R. G., Martin J. P., Pierfederici S. and Davat B., “Flatness based control of an isolated three port bidirectional DC-DC converter for a fuel cell hybrid source”, in ECCE 2011, pp.977 - 984.
11. Hariharan Krishnaswami and Ned Mohan, “Three-Port Series-Resonant DC-DC Converter to Interface Renewable Energy Sources With Bidirectional Load and Energy Storage Ports”, IEEE Trans. on Power Electronics, Vol. 24, No.10, October 2009, pp.2289-2297.
12. Danwei Liu and Hui Li, “A ZVS Bi-Directional DC-DC Converter for Multiple Energy Storage Elements”, IEEE Trans. on Power Electronics, Vol. 21, No.5, September 2006, pp.1513-1517
13. Oggier G. G., Botalla L. P. and Garcia G. O., “Soft-switching analysis for three-port bidirectional DC-DC converter”, in INDUSCON 2010, pp.1 - 6.
14. Botalla L. P., Oggier G. G., Airabella A. M. and Garcia G. O., “Analysis and evaluation of power switch losses for three-port bidirectional DC-DC converter”, in ICIT 2012, pp.950 - 955.
15. Chuanhong Zhao, Simon D. Round and Johann W. Kolar, “An Isolated Three-Port Bidirectional DC-DC Converter With Decoupled Power Flow Management”, IEEE Trans. on Power Electronics, Vol. 23 No.5, September 2008, pp.2443-2453
16. Zhixiang Ling, Hui Wang, Kun Yan, Zaoyi Sun, “A New Three-port Bidirectional DC/DC Converter for Hybrid Energy Storage”, in IFEEC 2015, pp.1-5.
17. Mathepot Phattanasak, Roghayeh Gavagsaz-Ghoachani, Jean-Philippe Martin, Babak Nahid-Mobarakeh, Serge Pierfederici and Bernard Davat, “Control of a Hybrid Energy Source Comprising a Fuel Cell and Two Storage Devices Using Isolated Three-Port Bidirectional DC-DC Converters”, IEEE Trans. on Industry Applications, Vol. 51, No.1, January/February 2015, pp.491-497.
18. Samavatian V., Bathae S. M. T. and Fereidunian A., “Half-bridge current-fed multi-resonant bidirectional three-port DC converter for flexible distributed generation”, in PEDSTC 2014, pp.172 - 176.
19. Wang L., Wang Z. and Li H., “Asymmetrical duty cycle control and decoupled power flow design of a three-port bidirectional DC-DC converter for fuel cell vehicle application”, IEEE Trans. on Power Electronics 2012, Vol.27, No.2, pp. 891-904.
20. Biswas S., Dhople S. and Mohan N., “A three-port bidirectional DC-DC converter with zero-ripple terminal currents for PV/microgrid applications”, in IECON 2013, pp.340 - 345.
21. Jianwu Zeng, Wei Qiao, Liyan Qu and Yanping Jiao, “An Isolated Multiport DC-DC Converter for Simultaneous Power Management of Multiple Different Renewable Energy Sources”, IEEE Journal of Emerging and Selected topics in Power Electronics, Vol. 2, No.1, March 2014, pp.70-78.
22. Serkan Dusmez, Xiong Li and Bilal Akin, “A New Multiinput Three-Level DC/DC Converter”, IEEE Trans. on Power Electronics, Vol. 31, No.2, February 2016, pp.1230-1240
23. Sixifo Falcones, Rajapandian Ayyanar and Xiaolin Mao, “A DC-DC Multiport-Converter-Based Solid-State Transformer Integrating Distributed Generation and Storage”, IEEE Trans. on Power Electronics, Vol. 28, No.5, May 2013, pp.2192-2203
24. Hongfei Wu, Junjun Zhang, Xiaoqing Qin, Tiantian Mu, and Yan Xing, “Secondary-Side-Regulated Soft-Switching Full-Bridge Three-Port Converter Based on Bridgeless Boost Rectifier and Bidirectional Converter for Multiple Energy Interface”, IEEE Trans. on Power Electronics, Vol. 31, No.7, July 2016, pp.4847-4860.
25. Maria C. Mira, Zhe Zhang, Arnold Knott and Michael A.E. Anderson, “Power Flow Control of a Dual-Input Interleaved Buck/ Boost Converter with Galvanic Isolation for Renewable Energy Systems”, in APEC 2015, pp.3007-3012.
26. Xiaofeng Sun, Yanfeng Shen, Wuying Li, “A Novel LLC Integrated Three-port DC-DC Converter for Stand-alone PV/Battery System”, ITEC Asia Pacific 2014, pp.1-6

27. Zeng J., Qiao W. and Qu L, “ An isolated three-port bidirectional DC-DC converter for photovoltaic systems with energy storage”, in Industrial Application Society Annual Meeting 2013, pp.1 - 8.
28. Junjun Zhang, Hongfei Wu, Xiaoqing Qin, and Yan Xing, “PWM Plus Secondary-Side Phase-Shift Controlled Soft-Switching Full-Bridge Three-Port Converter for Renewable Power Systems”, IEEE Trans. on Industrial Electronics, Vol. 62, No.11, November 2015, pp.7061-7072.
29. Zhihui Ding, Chen Yang, Zhao Zhang, Cheng Wang and Shaojun Xie, “A Novel Soft-Switching Multiport Bidirectional DC-DC Converter for Hybrid Energy Storage System”, IEEE Trans. on Power Electronics, Vol. 29, No.4, April 2014, pp.1595-1609
30. Sun X., Liu F., Xiong L. and Wang B, “Research on dual buck/boost integrated three-port bidirectional DC/DC Converter”, in ITEC Asia-Pacific 2014, pp. 1 - 6.
31. Hongfei Wu, Peng Xu, Haibing Hu, Zihu Zhou, and Yan Xing, “Multiport Converters Based on Integration of Full-Bridge and Bidirectional DC-DC Topologies for Renewable Generation Systems”, IEEE Trans. on Industrial Electronics, Vol. 61, No.2, February 2014, pp.856-869.
32. Hongfei Wu, Kai Sun, Runruo Chen, Haibing Hu and Yan Xing, Member, “Full-Bridge Three-Port Converters With Wide Input Voltage Range for Renewable Power Systems”, IEEE Trans. on Power Electronics, Vol. 27, No.9, September 2012, pp.3965-3974
33. Parthiban R.,and Rajammal K, “Performance investigation of three-port converter for hybrid energy system”, in ICEES 2014, pp.261 - 266.
34. Qian Z., Rahman O. A., Zhang K., Hu H., Shen J. and Batarseh I, “Design and analysis of three-port DC/DC converters for satellite platform power system”, in ECCE 2011, pp.1454 - 1460.
35. Zhijun Qian, Osama Abdel-Rahman, Haibing Hu and Issa Batarseh, “An Integrated Three-port Inverter for Stand-alone PV Applications”, in ECCE 2010, pp.1471-1478
36. Zhan Wang and Hui Li, “An Integrated Three-Port Bidirectional DC-DC Converter for PV Application on a DC Distribution System”, IEEE Trans. on Power Electronics, Vol. 28, No.10, October 2013, pp.4612-4624
37. Yuxiang Shi, Rui Li, Yaosuo Xue and Hui Li, “Optimized Operation of Current-Fed Dual Active Bridge DC-DC Converter for PV Applications”, IEEE Trans. on Industrial Electronics, Vol. 62, No.11, November 2015, pp.6986-6995
38. Zhu H., Zhang D., Athab H. S., Wu B. and Gu Y, “PV isolated three-port converter and energy-balancing control method for PV-battery power supply applications”, IEEE Trans. on Industrial Electronics 2015, Vol.62, No.6, pp.3595-3606.
39. Hongfei Wu, Runruo Chen, Junjun Zhang, Yan Xing, Haibing Hu, and Hongjuan Ge, “A Family of Three-Port Half-Bridge Converters for a Stand-Alone Renewable Power System”, IEEE Trans. on Power Electronics, Vol. 26, No.9, September 2011, pp.2697-2707
40. Wu H., Xing Y., Chen R., Zhang J., Sun K. and Ge H, “ A three-port half-bridge converter with synchronous rectification for renewable energy application”, in ECCE 2011, pp.3343 - 3349.
41. Zhijun Qian, Osama Abdel-Rahman and Issa Batarseh, “An Integrated Four-Port DC/DC Converter for Renewable Energy Applications”, IEEE Trans. on Power Electronics, Vol. 25, No.7, July 2010, pp.1877-1887.
42. Wenfei Hu, Hongfei Wu, Yan Xing and Kai Sun, “A Full-Bridge Three-Port Converter for Renewable Energy Application”, in APEC 2014, pp.57-62.
43. Hongfei Wu, Kai Sun, Lili Zhu, Yan Xing, “An Interleaved Half-Bridge Three-Port Converter with Enhanced Power Transfer Capability Using Three-Leg Rectifier for Renewable Energy Applications”, IEEE Journal of Emerging and Selected Topics in Power Electronics, Vol.4, Iss:2, 2016, pp.1-10.
44. Lili Zhu, Hongfei Wu, Peng Xu, Haibing Hu, Hongjuan Ge, “A Novel High Efficiency High Power Density Three-Port Converter Based on Interleaved Half-Bridge Converter for Renewable Energy Applications”, in ECCE 2014, pp.5085-5091.
45. Chien L. J., Chen C. C., Chen J. F., and Hsieh Y. P, “ Novel three-port converter with high-

- voltage gain”, IEEE Trans. on Power Electronics 2014, Vol.29, No.9, pp.4693–4703.
46. Hongfei Wu, Junjun Zhang, and Yan Xing, “A Family of Multiport Buck–Boost Converters Based on DC-Link-Inductors (DLIs)”, IEEE Trans. on Power Electronics, Vol. 30, No. 2, February 2015, pp.735-746.
 47. Lalit Kumar and Shailendra Jain, “Multiple-input DC/DC converter topology for hybrid energy system”, IET Power Electron., 2013, Vol. 6, Iss. 8, pp. 1483–1501.
 48. Alves D. B. S., Praca P. P., Oliveira Jr. D. S., Barreto L. H. S. C., and de Freitas L. C. G., “A single-stage three-port boost converter with high voltage gain based on the bidirectional version of the three-state switching cell”, in APEC 2015, pp.1934 - 1940.
 49. Hongfei Wu, Yan Xing, Yanbing Xia, Kai Sun, “A Family of Non-Isolated Three-Port Converters for Stand-Alone Renewable Power System”, in IECON Industrial Electronics Society 2011, pp.1030-1035
 50. Moumita Das and Vivek Agarwal, “Design and Analysis of a High-Efficiency DC–DC Converter With Soft Switching Capability for Renewable Energy Applications Requiring High Voltage Gain”, IEEE Trans. on Industrial Electronics Vol. 63, No.5, May 2016, pp.2936-2944
 51. Vazquez N., Sanchez C. M., Hernandez C., Vazquez E., Lesso R, “A three-port converter for renewable energy Applications”, in ISIE 2011, pp.1735 - 1740.
 52. Chen Y., Wen G., Peng L., Kang Y., J. Chen, “A family of cost-efficient non-isolated single-inductor three-port converters for low power stand-alone renewable power applications”, in APEC 2013, pp.1083 - 1088.
 53. Xiaoling Xiong, Chi K. Tse, and Xinbo Ruan, “Bifurcation Analysis and Experimental Study of a Multi-Operating-Mode Photovoltaic-Battery Hybrid Power System”, IEEE Journal of Emerging and Selected topics in Circuits and Systems, Vol.5, No.3, September 2015, pp.316-326
 54. Hongfei Wu, Kai Sun, Shun Ding and Yan Xing, “Topology Derivation of Nonisolated Three-Port DC–DC Converters From DIC and DOC”, IEEE Trans. on Power Electronics, Vol. 28, No. 7, July 2013, pp.3297-3307
 55. Junkai Zhao, Herbert H.C. Iu, Tyrone Fernando, Le An and Dylan Dah-Chuan Lu, “Design of a Non-Isolated Single-Switch Three-Port DC-DC Converter for Standalone PV-Battery Power System”, in ISCAS 2015, pp.2493-2496
 56. F. Akar, Y. Tavlasoglu, E. Ugur, B. Vural, I. Aksoy, “A Bidirectional Non-Isolated Multi-Input DC-DC Converter for Hybrid Energy Storage Systems in Electric Vehicles”, IEEE Trans. on Vehicular Technology 2015, pp.1-12
 57. Farzam Nejabatkhah, Saeed Danyali, Seyed Hossein Hosseini, Mehran Sabahi, and Seyedabdolkhalegh Mozaffari Niapour, “Modeling and Control of a New Three-Input DC–DC Boost Converter for Hybrid PV/FC/Battery Power System”, IEEE Trans. on Power Electronics, Vol. 27, No.5, May 2012, pp.2309-2325
 58. Shun Ding, Hongfei Wu, Yan Xing, Yu Fang and Xudong Ma, “Topology and Control of a Family of Non-Isolated Three-port DC-DC Converters with a Bidirectional Cell”, in APEC 2013, pp.1089-1094
 59. Saeed Danyali, Seyed Hossein Hosseini and Gevorg B. Gharehpetian, “New Extendable Single-Stage Multi-input DC–DC/AC Boost Converter”, IEEE Trans. on Power Electronics, Vol. 29, No.2, February 2014, pp.775-788
 60. Junjun Zhang, Hongfei Wu, Jun Huang, Yan Xing and Xudong Ma, “A Novel Multi-Port Bidirectional Converter for Interfacing Distributed DC Micro-Grid”, in ISIE 2014, pp.2344-2348
 61. Mohammad Reza Banaei, Hossein Ardi, Rana Alizadeh and Amir Farakhor, “Non-isolated multi-input–single-output DC/DC converter for photovoltaic power generation systems”, IET Power Electron., 2014, Vol. 7, Iss. 11, pp. 2806–2816
 62. Yaow-Ming Chen, Yuan-Chuan Liu, Shih-Chieh Hung, and Chung-Sheng, “Multi-Input Inverter for Grid-Connected Hybrid PV/Wind Power System”, IEEE Trans. on Power Electronics, Vol. 22, No.3, May 2007, pp. 1070-1077
 63. Zhang P., Chen Y., Zhou Z. and Kang Y, “The cost-efficient, common-ground, non-isolated three-port converter deduced from the single-

- inductor dual-output topology”, in APEC 2015, pp.2020 - 2025.
64. Song Y., Wang B, “ Survey on reliability of power electronic systems”, IEEE Transactions on Power Electronics 2013; 28(1): 591–604.
65. Yang S., Bryant A., Mawby P., Xiang D., Ran L., Tavner P, “An industry-based survey of reliability in power electronic converters”, IEEE Transactions on Industrial Applications 2011; 47(3): 1441–1451.
66. Mohammad Khalilzadeh, Karim Abbaszadeh , “Non-isolated high step-up DC–DC converter based on coupled inductor with reduced voltage stress”, in IET Power Electron., 2015, Vol. 8, Iss.11, pp. 2184–2194.
67. Y. Zhao W. Li Y. Deng X. He , “High step-up boost converter with passive lossless clamp circuit for non-isolated high step-up applications”, in IET Power Electron., 2011, Vol. 4, Iss. 8, pp. 851–859.
68. Teymour H. R., Sutanto D., Muttaqi K. M., Ciuffo P, “ Solar PV and battery storage integration using a new configuration of a three-level NPC inverter with advanced control strategy”, IEEE Transactions on Energy Conversion 2014; 29(2): 354–365.
69. Jayasinghe S. D. G., Vilathgamuwa D. M., Madawala U. K, “Diode-clamped three-level inverter-based battery/supercapacitor direct integration scheme for renewable energy system”, IEEE Transactions on Power Electronics 2011; 26(12): 3720–3729.
70. Peng F.Z., hen M., Holland K, “Application of Z- source inverter for traction drive of fuel application of Z- source inverter for traction drive of fuel cell –battery hybrid electric vehicles”, IEEE Transactions on Power Electronics 2007; 22(3): 1054-1061.
71. Jorge G. C. R., Li Y., Jiang S., Peng F. Z, “ Quasi-Z-source inverter with energy storage for photovoltaic power generation systems”, in APEC; 2011: 401 - 406.
72. Liu J., Jiang S., Cao D., Peng F. Z, “ A digital current control of quasi-Z-source inverter with battery”, IEEE Transactions on Industrial Informatics 2013; 9(2): 928–937.
73. Liu Y., Ge B., Haitham A. R., Peng F. Z, “ Control system design of battery-assisted quasi-Z-source inverter for grid-tie photovoltaic power generation”, IEEE Trans. on Sustainable Energy, Vol.4, No.4, 2013, 994–1001.
74. Haitham A. R., Iqbal A., Ahmed SK. M., Peng F. Z., Li Y., Ge B, “ Quasi-Z-source inverter-based photovoltaic generation system with maximum power tracking control using ANFIS”, IEEE Trans. on Sustainable Energy, Vol.4, No.1, 2013, pp.11–20.
75. Liu Y., Ge B., Haitham A. R., Peng F. Z, “ Modelling and controller design of quasi-Z-source inverter with batterybased photovoltaic power system”, IET Power Electronics, Vol.7, No.7, 2014,pp.1665–1674.
76. Ge B., Haitham A. R., Peng F. Z., Lei Q., Almeida A. T. de, Ferreira F. J. T. E., Sun D., Liu Y, “ An energy-stored quasi-Z-source inverter for application to photovoltaic power system”, IEEE Trans. on Industrial Electronics, Vol. 60, No.10, 2013, pp. 4468–4481.