

# A NEW METHOD FOR COMPUTATION OF DYNAMIC INDUCTANCE OF TUBULAR MOTOR

Sandhya Thotakura\*<sup>1</sup>, Mallikarjuna Rao Pasumarthi<sup>2</sup>

\*<sup>1</sup> Research Scholar, Department of EE, Andhra University, Visakhapatnam, India, email:sandhyathotakura@gmail.com

<sup>2</sup> Professor, Department of EE, Andhra University, Visakhapatnam, India, email:electricalprofessor@gmail.com

**Abstract**—Static and dynamic inductances are critical technical parameters of electromagnetic systems during the designing process. The static inductance is used for estimating the stored energy, magnetic flux linkage in coils at instantaneous currents. The dynamic inductance interprets the interrelation between the instantaneous flux linkage and currents governing the transient process in coils. This article presents a study and computation of coil inductance and force profile in a tubular electromagnetic motor with closed type magnetic circuits. The equations for dynamic inductance of the drive coil and the magnetic force on the basis of the magnetic field analysis are derived. The derived expressions handle the flux distribution at the boundary layers of the coil under consideration so that the leakages effects are reflected in the comparisons unlike earlier methods available in literature. Further a simulation methodology is proposed with the model parameters for the best system geometry. Electromagnetic finite field distributions are validated using CAD software

**Keywords**— Magnetic field distribution, Permeance, Reluctance, Dynamic and static inductance

## I. INTRODUCTION

The electromagnetic tubular motors avail magnetic energy to change the electrical energy into kinetic energy. The transformation is possible to magnetic field that is generated around the electric wires. The coils are the primary constructional elements of an electromagnetic tubular motor to propel the objects namely a slider (secondary). The slider is a conducting hollow structure which can carry the propelling objects. The field that is generated by the coils pulls the slider into it and accelerates it out with a possible muzzle velocity. Consequently, the coil parameters calculation process is a prerequisite to build a fully efficient device. The precise selection of coil dimensions is essential to achieve maximum velocity to thrown slider out. The force acting on a slider depends on product of current flowing through wires and change in inductance profile. Therefore, the coils dynamic inductance parameter plays an important role in the process of an electromagnetic tubular motor operation.

The complex topic of inductance calculation of electromagnetic coils is initiated in [1]. This covers many methods to solve for different inductance values with look up tables, including formulas for various models of symmetrical and unsymmetrical coil geometries. Many inductance calculations require complex mathematical methods such as elliptical integrals of the first, second, and third kind to solve.

The accurate self-inductance and mutual inductance expressions for thin circular coils (thin-wall solenoids and disk coils) were derived and presented in [2] using Jacobian elliptic functions and Heumann's Lambda functions. The position of the projecting object was not considered for inductance calculation; in fact shape factors have been used. A method based on Bessel function integrals has been developed to calculate the inductance of non coaxial coils in [3]. A study of coil inductance in every plunger positions in tubular linear reluctance motors (TLRMs) with open type magnetic circuit was presented in [4]. In any of the previous literatures, the calculation of dynamic inductance was not reflected with magnetic flux distribution and leakages with respect to the position and movement of the sliding object. Most of the articles are confined to equal length of the primary (drive coil) and secondary (slider).

During the launch process when the slider move inside the coil, the inductance of the coil continuously changes, as the reluctance offered on the flux distribution in the medium vary. This change in inductance is stated as the dynamic inductance. This dynamic inductance mainly depends on the magnetic flux distribution in the tubular motor. Magnetic flux always form closed loops and the path of the loops depend on the reluctance of the surrounding materials. All available literature mainly aimed on the static inductance calculation of the drive coils. In this aspect, no past literature [8-14] has focused on the computation of the dynamic inductance of the drive coil, during the movement of the slider considering the complete flux distributions and reluctances of the medium. The aim of the proposed approach is to find a solution to derive the dynamic inductance in a tubular motor system. Such approach was adopted as the coil parameters vary according to the movement of the slider in the motor.

This article presents a new, relatively simple and more accurate procedure for the calculation of the inductance of thin-walled coils of circular shape of a tubular motor. The coils are with parallel axes, parallel walls and that are tightly wound in an axial direction, without any space between turns. The calculation procedure is designed and applicable for coils of a finite axial length. For thin-walled circular coils, the design of circular coil is treated as a cut open rectangular view.

## II. ELECTRIC AND MAGNETIC EQUIVALENT CIRCUITS AND EQUATIONS

An Electromagnetic tubular motor consists of stationary series of coils called a barrel with a moving slider. There are two distinct types of tubular motors. The first is the reluctance tubular motor which uses the attractive ferromagnetic properties of the slider to generate acceleration. The second type is the induction tubular motor in which the accelerating force is repulsive and comes from the eddy currents induced in the slider when the coil is fired. The simple geometrical view of a tubular motor is shown in fig.1.

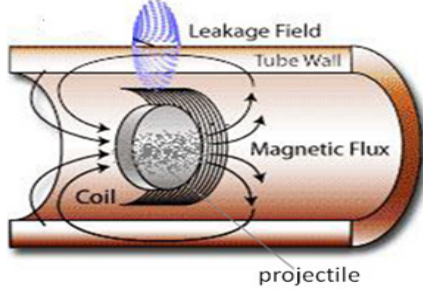

Fig.1 Simple tubular motor geometry

The major consideration in designing a tubular motor is to minimize the size of the motor needed to achieve specified energy at the muzzle, within the limitations of the allowable electrical, magnetic, mechanical and thermal stresses of the materials. The performance of any system can be analyzed from the electrical equivalent properties of the operating system. Hence a simple electrical circuit is adopted to represent the properties of the tubular motor system during its operation as shown in fig 2.

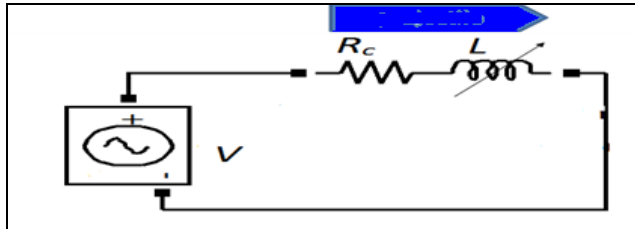

Fig 2. Electrical equivalent of tubular motor

### A. Equivalent Circuit Components

#### Coil Resistance [ $R_c$ ]

It is quite straightforward to derive an equation which will give us the coil resistance to an accuracy of better than +/- 10%. The following equation uses the main parameters such as coil outer diameter ' $d_o$ ', inner diameter ' $d_i$ ', length of the

coil ' $l_c$ ', thickness of the coil ' $c$ ', Number of turns ' $N$ ' and conductor diameter ' $d_w$ ' to calculate the resistance of the coil.

$$R_c = \frac{\rho_w l_w}{A_w} \quad (1)$$

Where  $l_w$  represents the total length of the conductor wire used to make a coil of ' $N$ ' number of turns, derived by

$$l_w = \pi (d_i + d_w) N \frac{c}{d_w} \quad (2)$$

#### Dynamic Inductance Calculation [ $L(x)$ ]

Inductance can be described as the ratio of flux linkage to the current producing the flux. It is important to realize that the inductance is only a constant if the loop has an 'air core', i.e. surrounded by air. When a ferromagnetic material is part of the magnetic 'circuit' it introduces a non-linear behavior into the system which results in a variable self inductance.

During the design of an electromagnetic tubular motor, the inductance profile of the launching system as the inductance varies with the relative position of the slider inside the coil, to achieve a specified energy at the muzzle, within the limitations of the allowable electrical, magnetic, mechanical and thermal stresses of the materials.

The tubular motor operation is based on the tendency of its movable part to move to a position with higher inductance or, in other words, lower reluctance. This is exactly how force and velocity are produced in the electromagnetic motor. As the slider moves into the coil, its material reduces the reluctance and therefore magnetic force is developed due to the change in system reluctance. The slider has a greater magnetic permeability than the air it replaces. As a consequence, the magnetic flux can be formed more easily when the slider is placed in the center of the coil. At this point, the reluctance is at its minimum for a given flux level; it is also the position of the least energy. When displaced from the centered position, magnetic forces will always act to restore the slider to its previous position. Here we describe a method to calculate the winding inductance based on the position of the slider inside it.

The inductance is a function of coil and slider dimensions, excitation current, and position of the slider. The coil inductance,  $L$ , is determined according to the position of the slider inside the coil. The coil has a minimum inductance when the object is completely out of the coil and it has maximum inductance when the object completely fills the coil

(i.e. inside the coil). Therefore the inductance profile is a combination of minimum and maximum inductance values, where inductance profile  $L(x)$  is represented with important parameters on which it is mainly depending as follows

$$L(x) = f(l_c, l_p, N, x) \quad (3)$$

where  $l_c$ =coil length,  $l_p$ =slider length,  $N$ = Coil turns,  $x$ = Position.

*Formulation with flux distribution*

In general, the coil inductance  $L$  is determined from the magnetic flux linkage and the permeance. Magnetic flux always forms a closed loop, as described by Maxwell's equations but the path of the loop depends on the reluctance of the surrounding materials. It is concentrated around the path of least reluctance. Air and vacuum have high reluctance, while easily magnetized materials such as soft iron have low reluctance. The concentration of flux in low-reluctance materials forms strong temporary poles and causes mechanical forces that tend to move the materials towards regions of higher flux. Hence when a coil is energized, the flux lines try to travel along the least reluctance regions.

Flux going around a corner tends to "crowd in" toward the inside of the curve. When Flux lines are close together, magnetic forces are high and where they are far apart, forces are lower. Flux lines cannot cross each other and must close on themselves into loops. With uniform flux-density in the gap, material and no leakage of flux, the equivalent reluctance is easy and just the summation of the two.

When the flux-density varies within the volume, a more general relationship is needed where the volume may be considered as being broken up into flux-tubes. A flux-tube is an imaginary closed wall in space, which is everywhere parallel to the direction of flux at its surface so that no flux crosses the wall. Both the cross-sectional area of the tube and the field contained may vary along the length of the tube, but the magnetic flux is always constant. In many practical cases it is very important to accomplish the parameters of each tube individually to approximate the resultant values of reluctance. Hence the total magnetic path in the flux tube has to be categorized into regions based on the reluctance offered.

The method for analytical estimation of reluctance of the fixed flux path in electromagnetic circuit has been developed using this flux distribution. The circuit analysis requires reluctance calculated from the permeance for various flux paths, as the accuracy of the magnetic equivalent depend on the reluctance. For this reason, the analytical calculation of permeance of each flux tube according to the movement of

slider inside the coil is developed. Magnetic reluctance depends on the geometric shape and permeability of the material. The magnetic flux distribution in the air gap can be approximately modeled using the simple elements with shapes shown in Fig 3. The magnetic reluctances of these elements depend on physical dimensions of the flux paths. Three basic cases were studied; slider at the entrance of the coil, slider at a distance 'x' from the entrance, slider at the muzzle. In accordance with the case study a generalized formula for permeance and reluctance has been developed and finally the inductance profile.

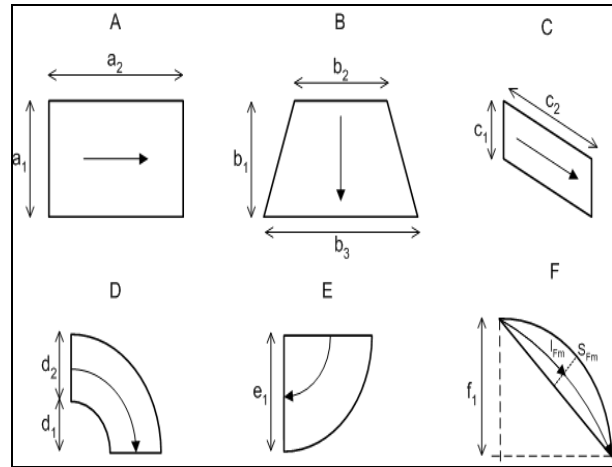

Fig.3 Models of Magnetic flux distribution shape.

Figure 4 shows the field distribution in the cut open flat view of the top section in a tubular motor during the movement of the slider. Flux distribution of the system with slider at the entrance of the coil and moved to a distance of 'x' inside the coil is shown in fig 4. The total permeance is the sum of all permeances in every flux paths from 1-7.

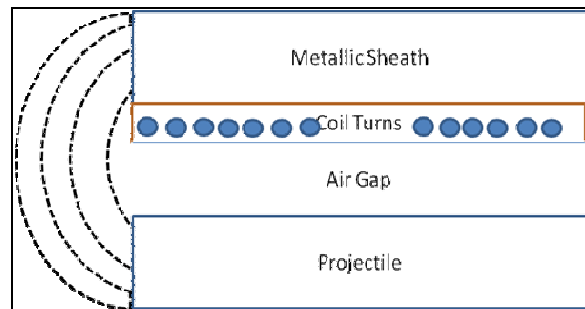

Fig. 4 Flux distribution in launch system when slider inside the coil

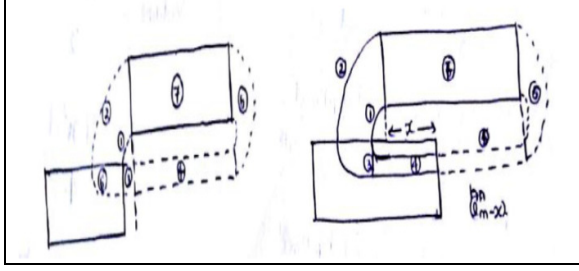

Fig.5. Flux lines representation at different positions of slider

Permeance in Flux path 1,

$$P_1 = 0.318 \mu_0 d \quad (4)$$

Permeance Flux path 2,

$$P_2 = \mu_0 h_m d / \pi (h_m + l_g) \quad (5)$$

Permeance in Flux path 5,

$$P_5 = \mu_0 h_p d / 2(l_m - x) \quad (6)$$

Permeance in Flux path 6,

$$P_6 = \mu_0 (h_m + h_p d / 2) / 2\pi (h_m / 2 + h_p + l_g) \quad (7)$$

Permeance in slider i.e. in path 3 and 4 are

$$P_3 = 16\mu_0 \mu_r h_p h_m d / 4h_m^2 + h_p^2 \quad (8)$$

$$P_4 = \mu_0 \mu_r d / 2x \quad (9)$$

Coil Permeance is given by

$$P_7 = \mu_0 \mu_r h_m d / l_m \quad (10)$$

Finally, the total reluctance offered by the magnetic field in the launch system with the slider positioned at a distance 'x' from the entrance of the coil is

$$R_{total} = 1/P_1 + 1/P_2 + 1/P_5 + 1/P_6 + 1/P_3 + 1/P_4 + 1/P_7. \quad (11)$$

The final expression for the dynamic inductance of the coil with flux distribution is

$$L(x) = N^2 / R_{total} \quad (12)$$

For the magnetic flux distribution, an equivalent magnetic circuit is represented. These magnetic circuits are built through the parallel and series association of simple flux

distributed elements.  $R_1, R_2, R_5, R_6$  represents the reluctance of the air gap flux and  $R_3, R_4$  &  $R_7$  are reluctance to the flux flow in the slider material and the coil sheath.

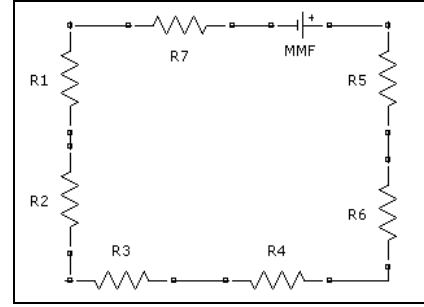

Fig.6 Equivalent magnetic circuit

## B. Design Strategy

The selection of proper size of the conductor is very important while designing the coil as heavy transient current will flow in a short period to accelerate the slider. Hence a smaller conductor gauge with more turns per coil increases the magnetic field while a bigger gauge allows more currents. These features of conductor translate into ability to increase the reloading capability of the coil for more shots. An external metal enclosure is used to cover the coils to guide the magnetic flux with low reluctance in the barrel.

The physical geometry of the coil decides the magnetic property of it during the firing. The physical dimensions can be scaled to yield the demanding magnetic field and kinetic energy. The scaling is done by altering the number of turns, inner and outer the diameter of the coils with multi layered turns to meet the required muzzle velocity of the system. Further, addition of coils will add more strength in imparting the energy to the slider to achieve higher velocities. Hence number of sections during the design is improved in the specified range of the barrel length to achieve the target velocity efficiently and reliably. The slider is chosen with a material offering low reluctance to the magnetic field, such that it will increase the efficiency of energy transfer during the operation.

## C. Modeling of flux distribution

A mathematical model is developed with the derived formulas using flux distribution from section A to observe the inductance profile, accelerated force and velocity achieved for various positions of the slider during launching. Figure 6 represents the model of a single stage tubular motor.

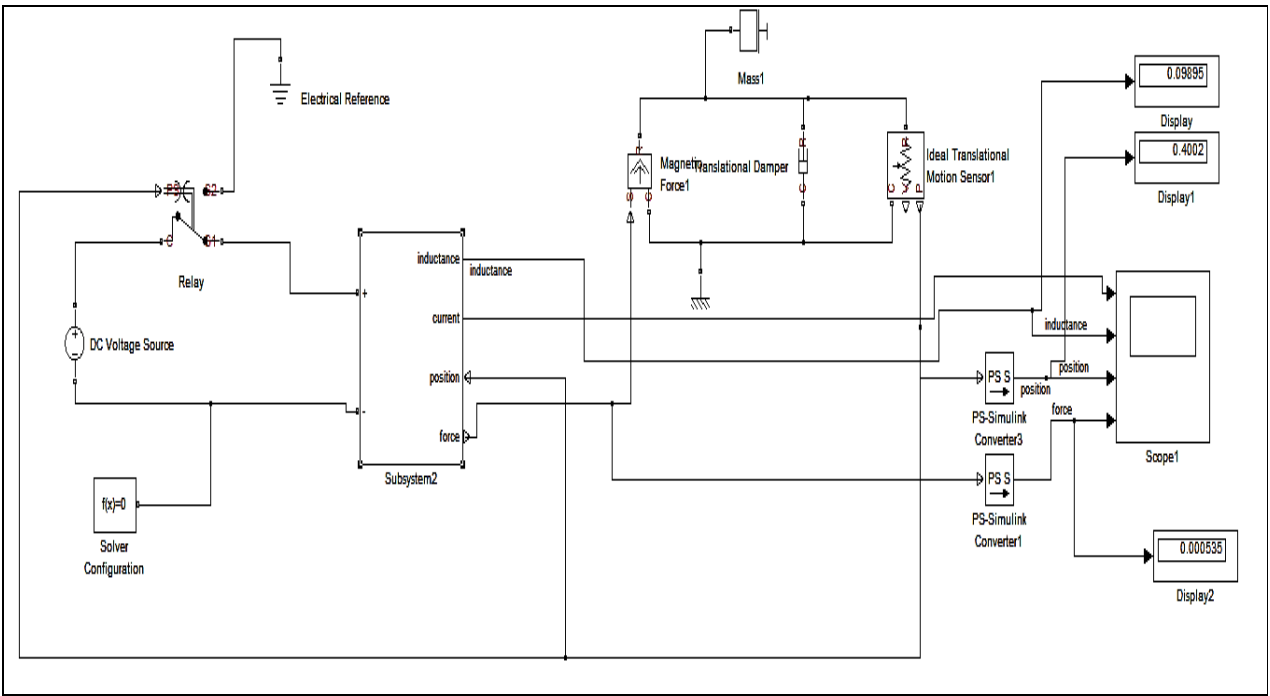

Fig 6. Model of single stage tubular motor

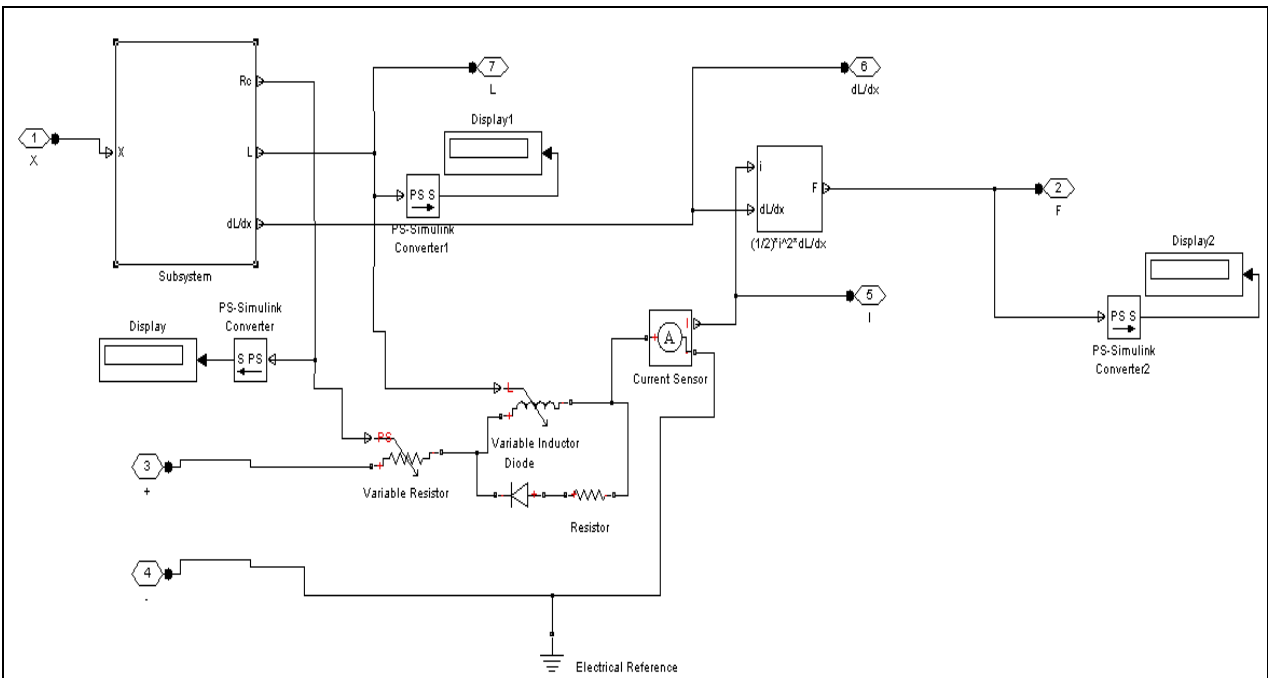

Fig 7. Subsystem for analysis of dynamic inductance

### III. OBSERVATIONS

According to the formulas derived a model is developed to observe the change in inductance in the tubular motor system. The dynamic inductance profile of the drive coil is shown in fig.8. The effect of change in diameter of the slider on the inductance profile is shown in fig 9.

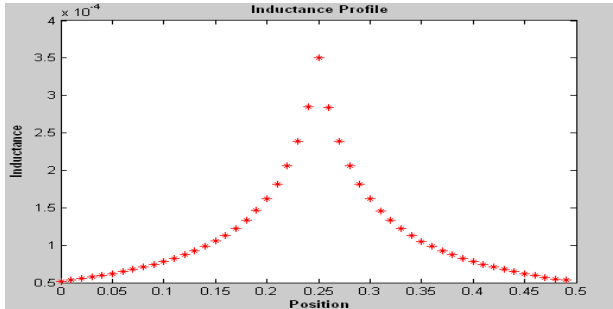

Fig.8. Dynamic inductance profile

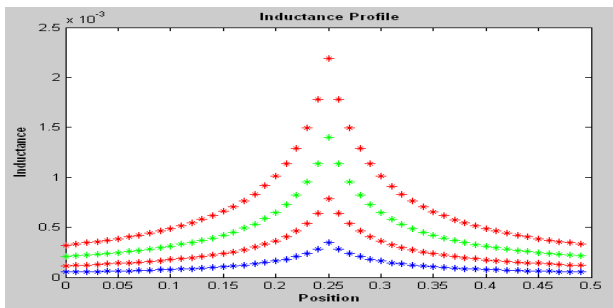

Fig.9. Inductance profile with change in diameter of the slider.

The magnetic field distributions in a single coil motor were observed with CAD software. Figures [10-13] represents the flux distribution and current density in a tubular motor system, where in the slider is at the starting of the coil and just leaving the coil. It is already known that, the magnetic flux in a medium depends on the reluctance offered. As the slider continues to move inside the drive coil, the opposition to the flux path decreases, as the slider is made with a ferromagnetic material having relatively high magnetic permeability. Hence the intensity of magnetic flux distributions changes with respect to the movement of the slider is observed from figures [10-13].

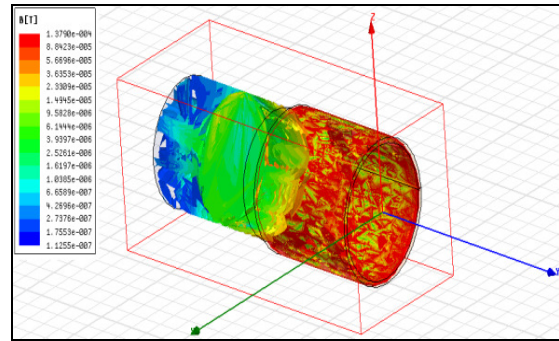

Fig.10. Magnetic Flux Density Plot-Slider Outside the coil

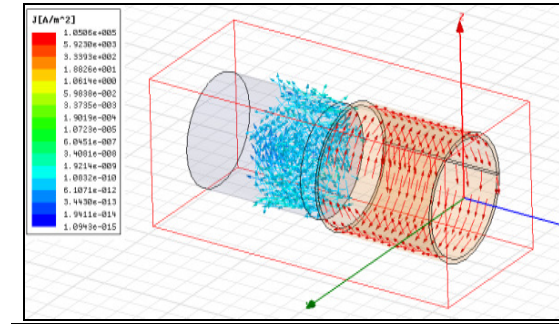

Fig.11. Current Density Plot - Slider Outside the coil

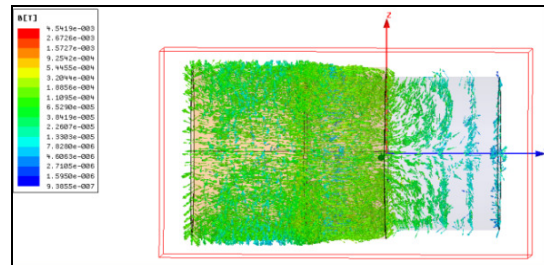

Fig.12. Flux Density Plot - Slider leaving the coil

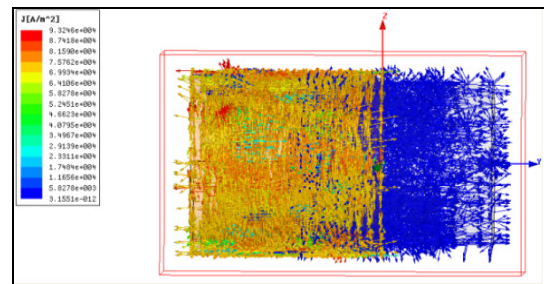

Fig.13. Current Density Plot - Slider leaving the coil

#### IV. CONCLUSION

The undertaken study revealed the attractiveness of the proposed method to find the dynamic inductance of a tubular motor from its physical dimensions. The application of this flux tube method requires a special knowledge about the flux distribution in the air gap region. Formula of the dynamic inductance of tubular motor during the journey of the slider in the drive coil is derived with this flux distribution method. As the reluctance offered on the flux changes with the permeability of the medium, the resultant reluctance formula is derived from the permeance offered by various flux paths. In practical applications the circular and rectangular coils are most frequently used; however the calculation method described here can easily be modified for the calculation of the inductance of coils of any random shapes. This is a valid and useful method that can be continued to improve the coil motor design optimization process. A powerful CAD tool is adopted to validate the flux distribution in the launch system.

#### References

- [1] Frederick W. Grover Inductance Calculations: Working Formulas and Tables
- [2] Slobodan Babic and Cevdet Akyel, "Improvement in calculation of the self and Mutual Inductance of Thin – wall Solenoids and Disk Coils", IEEE Transactions on Magnetics, Vol.36, No.4, July 2000.
- [3] John T.Conway," Inductance Calculation for Non coaxial Coils Using Bessel Functions", IEEE Transactions on Magnetics, Vol.43, No.3, March 2007K. Elissa, "Title of paper if known," unpublished.
- [4] Ali Mosallanejad, Abbas Shoulaie, "Calculation of Coil Inductance in Tubular Linear Reluctance Motor using Three Dimensional FEM", PRZEGLĄD ELEKTROTECHNICZNY (Electrical Review), ISSN 0033-2097, R. 87 NR 11/2011.
- [5] Gabriele Grandi et al.," Model of laminated iron Core Inductors for high frequencies ", IEEE Transactions on Magnetics, Vol.40, No.4, July 2004.
- [6] David W Knight," Solenoid Inductance Calculation ", Ottery St Mary, Devon, England, 2013.
- [7] Ph.G.Rutberg, G.A.Shvetsov,"Results of Recent Research on Electromagnetic Launch Technology in Russia",IEEE Transactions on Magnetics, Vol.39, No.1, January 2003.
- [8] Bin Lei, Xiao-cun Guan, Zhi-yuan Li and Bin-an Zhi ,,"Performance Analysis of Single Inductive Coil Driver ", IEEE Transactions on Plasma Science, Vol. 39, No. 1, January 2011.
- [9] António ESPÍRITO SANTO, Maria do Rosário CALADO, Carlos CABRITA, "Static Simulation of a Linear Switched Reluctance Actuator with the Flux Tube Method", Advances in Electrical and Computer Engineering, Volume 10, Number 2, 2010.
- [10] Philip T. Putman and Kamel Salama," Optimization of Energy Conversion in Monolithic Superconducting Magnets", IEEE Transactions on Applied Superconductivity, Vol. 13, No. 2, June 2003.
- [11] Y. P. Su, Xun Liu and S. Y. Ron Hui ,,"Mutual inductance Calculation of Movable Planar Coils on Parallel Surfaces", IEEE Transactions On Power Electronics, Vol. 24, No. 4, April 2009.
- [12] C. D. Sijoy and Shashank Chaturvedi ,," Calculation of Accurate Resistance and Inductance for Complex Magnetic Coils Using the Finite-Difference Time-Domain Technique for Electromagnetic" , IEEE Transactions On Plasma Science, Vol. 36, No. 1, February 2008.
- [13] Liang Yan *et al*, "Flux Distribution and Back-iron Influence of Tubular Linear Motors, "978-1-4244-8452-2/11/\$26.00 ©2011 IEEE.(FPM 2011)
- [14] Sami Barmada, "Analysis of the Performance of a Multi-Stage Pulsed Linear Induction Motor," IEEE Transactions On Magnetics, Vol. 37, No. 1, January 2001.