

# SIMULATION STUDIES ON THE DISTANCE RELAY PERFORMANCE IN THE PRESENCE OF STATCOM

**Sham M.V, Panduranga vittal K.**  
National Institute of Technology Karnataka,  
Surathkal P.O.575025, Karnataka, INDIA  
[shammv@rediffmail.com](mailto:shammv@rediffmail.com) [vittal\\_nitk@yahoo.com](mailto:vittal_nitk@yahoo.com)

**Abstract:** Flexible AC Transmission System (FACTS) devices are used to enhance the transient stability limit and power transfer capacity of the existing transmission lines. The mid-point compensation using static synchronous compensator (STATCOM) as a shunt FACTS device is common practice among utilities. But, the presence of STATCOM has influence on performance of the distance relay under normal operating conditions, as well as under fault conditions. This paper presents both analytical and simulation studies carried out using PSCAD/EMTDC on a transmission system connected with a STATCOM at the midpoint and its influence on distance relay performance. Simulation results shows that the presence of STATCOM on transmission line greatly affects the measured impedance at the relaying point.

**Key words:** Distance protection, FACTS devices, PSCAD/EMTDC, STATCOM

## 1. Introduction

The use of FACTS controllers in power system has been of worldwide interest in recent years for increasing the power transfer capability and enhancing power system controllability and stability. Developments in the field of power electronics, particularly Gate Turn-Off (GTO) based devices, have introduced a new family of FACTS controllers namely static synchronous compensator (STATCOM). The STATCOM based on voltage source converter (VSC) is used for voltage regulation in transmission and distribution systems. Inclusion of STATCOM changes dynamic behaviour of the power system and many sub-systems are affected, including the protective systems [1-3]. Therefore, it is essential to study effects of FACTS devices on the protective systems, especially the distance protection, which is the main protective device at EHV and HV level transmission systems.

Distance relays are used for the protection of transmission lines. They measure the impedance between the relay installation point and the fault location. The impedance of the transmission line per kilometer remains almost constant throughout the

length of the transmission line. Hence, the impedance measured by the relay is proportional to the distance to fault on the line.

This paper presents the modelling of Distance relay using PSCAD/EMTDC software package. The magnitude and phase of the fundamental sequence components is extracted using Full cycle discrete Fourier filter. The effect of compensation factor K on the performance on the distance relay has been reported in [4]. The study on optimal positioning of shunt FACTS devices has been presented in detail in [5]. The effect of shunt FACTS devices on the performance of impedance protection relays has been reported in [6] in which, the effect of fault resistance is not considered in the analysis. [7] have proposed a novel method of distance protection in transmission line with the presence of STATCOM. Authors of this paper have not reported the influence of zero sequence compensation factor 'k' on reach of relay during ground fault conditions. This paper treats compensation factor 'k' as a complex quantity, for modelling the distance relay and its performance in the presence of STATCOM while dealing with the single line to ground faults. In Section 2, performance of the distance relay is evaluated for all types of faults for the general power system model without the presence of STATCOM. The effect of ignoring the argument part of the compensator factor 'k' on the measured impedance is highlighted. In Section 3 operating principle of STATCOM is presented to introduce its influence on distance relaying is shown analytically. In section 4, the same power system model with STATCOM connected at the midpoint of the transmission line is simulated for various faults at different lengths of the line and results are presented.

## 2. SYSTEM MODEL

Shunt devices are most effective when connected at the centre of a transmission system and their effectiveness falls off rapidly when a change in the transmission

system throws them off-centre [5]. The power transfer capacity is increased to twice that of the uncompensated line. The mid-point sitting is also most effective in reactive power flow control to the power network and hence both the system voltage fluctuations and transient stability. They are rarely connected at the end of the line parallel to the load to prevent the voltage instability caused by load variations or generation or line voltages. In the present study, a transmission system connected with sources at both ends and a STATCOM connected at the midpoint as shown in figure 1 is chosen for the present study. Where  $E_s$  and  $E_r$  are the equivalent voltage sources with source impedances  $Z_s$  and  $Z_r$ . A distance relay is installed at the node M.

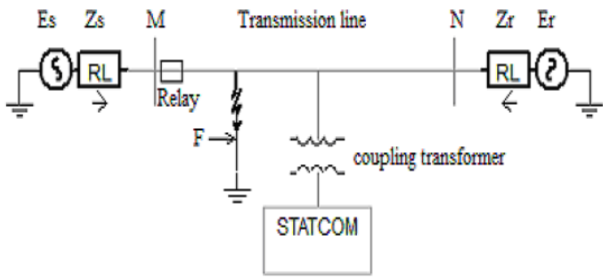

Figure 1. Two generator system with STATCOM.

The transmission line parameters are as given below:  
Length =180 kilometers.

$$Z_1 = Z_2 = 0.035744 + j0.507762 \quad \Omega/\text{KM},$$

$$C_1 = 0.00243 \mu\text{F}/\text{KM}.$$

$$Z_0 = 0.363152 + j1.326473 \quad \Omega/\text{KM}, C_0 = 0.001725 \mu\text{F}/\text{KM}.$$

Voltage level: 220KV

Source impedance:

$$Z_s = Z_r = 26.45 \angle 80^\circ$$

$$\delta = 20^\circ$$

The capacity of STATCOM is  $\pm 300$ MVAR. The leakage reactance of the coupling transformer  $X_T = 0.1$  P.U.

A fast Fourier technique based block available in the EMTDC/PSCAD with an inbuilt antialiasing filter with a sampling frequency of 800 Hz is used to calculate the magnitude and phase angle of the fundamental frequency component of the voltage and currents. Sequence components of the fundamental quantities are extracted using sequence component extractor block. Distance relay calculates the apparent impedance under different fault conditions using the formulas listed in the Table 1. Mho relay is used to

detect the fault and issue the trip signal. The functional block diagram of the distance relay is as shown in the figure 2.

Table 1. Formula for impedance calculation

Fault type	Formula
Line to ground faults	$V_x / (I_x + 3KI_0)$ ; Where X is faulted line
Line – Line / Line-Line-Ground faults.	$(V_x - V_y) / (I_x - I_y)$ ; Where X & Y are the faulted lines.
Three phase faults	$V/I$

In the Table 1 V and I are phasors of voltage and current,  $k = (Z_0 - Z_1) / Z_1$ . Where  $Z_0$  and  $Z_1$  are the zero sequence and positive sequence impedance of the transmission line respectively.  $I_0$  is the zero-sequence current.

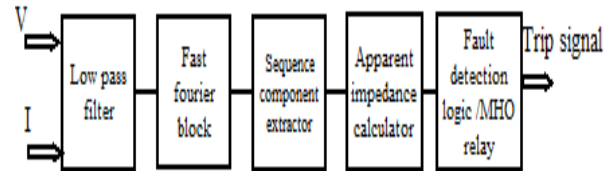

Figure 2. Functional block diagram of the distance relay.

Value of k for the transmission line considered is  $1.77 \angle -17.77^\circ$ . From the Table 1 it may be observed that the Zero sequence coupling only affects the line to ground units, however since most of the transmission line faults are of this type, this problem deserves special attention. The accurate measurement of R and X considering both magnitude and direction of the k is desired [4]. Measured values of both resistance and reactance differ significantly from the actual values when the angle part is ignored. In the present study distance relay is set to protect 85% of the transmission line. Figure 3 shows the effect of ignoring the angle part of 'k' for a single line to ground fault at 88% of the line length. When only real k is considered, it may be observed that, the impedance trajectory enters the mho characteristic and causes the relay operation resulting in overreaching of the relay. Figure 4 shows the voltage and current waveforms of Phase A for an A-G fault. Effect of ignoring the k factor argument on the R and X measurement for the line to ground faults at different line lengths are tabulated in the Table 2.

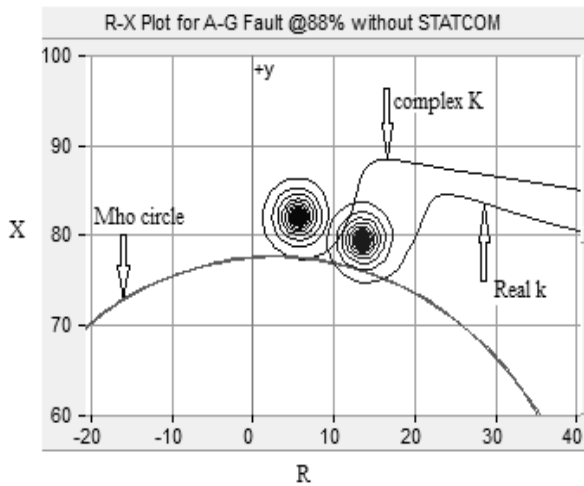

Figure 3. shows the influence of K factor phase angle on the R and X measurement

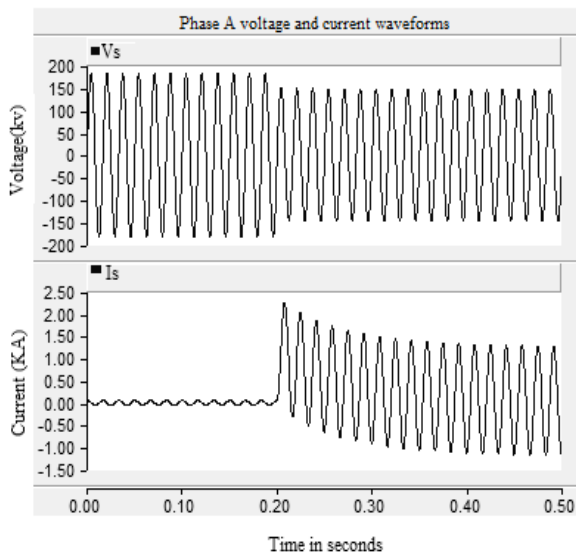

Figure 4. Phase A voltage and current waveforms for A-G fault.

Table 2. Effect of ignoring the k factor on measured R & X

Sl No	Fault distance (KM)	Actual R+jX	R+jX with  k  only	R+jX with $ k  \angle$
1	90	3.21+j45.69	8.26 + j44	3.21+j45.85
2	120	4.28+j60.9	10.78 + j58	4.26+j61.08
3	150	5.36+j76.6	13.26 + j74	5.34+j76.82

### 3. Operation of STATCOM and analysis of its behavior

Shunt type FACTS devices are connected to regulate

the voltage at the point of their connection. With the advancement in power electronic devices, devices such as Gate Turn Off thyristors lead to development of advanced static var systems (SVS), STATCOM is an example of such SVS .It consists of multiple sets of three phase GTO based switches, a DC link capacitor and associated control system. The control system operates in such a way that the voltage at the point of connection is regulated within its operation limits. STATCOM is modeled as a shunt branch consisting of voltage source inverter that produces a set of three phase voltages, each of which is in phase with and coupled to the corresponding phase via a relatively small reactance. This small reactance is usually provided by the per phase leakage reactance of the coupling transformer. The ac voltage difference across this transformer produces reactive power exchange between the STATCOM and the power system at the point of common coupling (PCC). The exchange of real power and reactive power can be controlled by adjusting the amplitude and phase of the converter output voltage. A typical six-pulse voltage-sourced inverter type,  $\pm 300$  MVAR STATCOM connected at the mid-point of the power system is shown in figure 1. In its simplest form it consists of six self-commutated semiconductor switches, GTOs, with the anti-parallel diode connected across each switch. STATCOM uses a capacitor for energy storage. A leading or lagging current is produced by appropriate control of the switching devices, so that the STATCOM in effect provides a static VAR Controller function. In this section model power system with the STATCOM used to regulate the voltage at the mid-point of the transmission line is simulated.

In the voltage control loop angle order based on voltage error will be generated.  $Q_m$ ; measured reactive power of the STATCOM and  $V_m$ ; measured voltage of the power system at the mid-point are used as the inputs.  $V_{Ref.}$ , the reference voltage at the bus is set at 1.0 pu.  $V_{err}$ ; error voltage is derived by calculating difference between  $V_m$  and  $V_{Ref.}$ . PI controller uses  $V_{err}$  as the input and produces necessary angle order which determines the direction and amount of real power flow. Phase locked loop is used to synchronize the switching to transmission system voltage and lock to the phase at fundamental frequency to generate the pulse width modulated triangular carrier signals. PWM technique with modulation index equal to one and carrier frequency of 33 times the fundamental frequency is used to generate the firing pulses.

Two cases are considered to analyze the effect of

STATCOM's presence on the distance protection. The cases differ only in the context of fault location. In Case I a close end fault is applied and in the case II a far end fault is considered.

Case I: Fault assumed to occur within 50% of the line length.

Case II: Fault assumed to occur beyond 50% of the line length.

Case I:

Under case I, the single line diagram of the system can be represented as shown in the figure 5. Where  $d$  is the percentage length of the line at which fault occurs.  $Z_{1L}$  is the Positive sequence impedance of the line.  $R_f$  is the Fault resistance,  $I_{sh}$  is the Shunt device STATCOM current,  $X_{sh}$  is the reactance of the coupling transformer. From the figure 5 the impedance measured by the relay at M can be written as

$$Z_{relay} = V_M / I_s = (dZ_{1L}I_s + I_f R_f) / (I_s) \quad (1)$$

$$dZ_{1L} + R_f \left( I_f / I_s \right) \quad (2)$$

$$I_f = I_s + I_r + I_{sh} \quad (3)$$

From the equation (2) we can see that the measured impedance is more than the actual impedance  $dZ_{1L}$ . It is affected by both fault resistance  $R_f$  and the STATCOM current  $I_{sh}$ . But for solid faults the measured impedance will not be affected by the presence of STATCOM

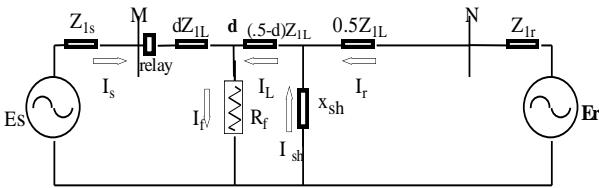

Figure 5. Single line diagram of system for case I.

Under case II, the single line diagram of the system can be represented as shown in the figure 6.

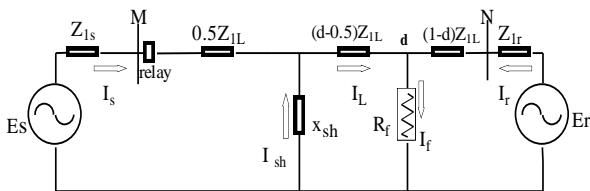

Figure 6. Single line diagram of system for case II.

Impedance seen by the relay

$$Z_{relay} = V_M / I_s \quad (4)$$

$$V_M = 0.5Z_{1L}I_s + (d - 0.5Z_{1L})(I_s + I_{sh}) + I_f R_f \quad (5)$$

$$Z_{relay} = dZ_{1L} + R_f \left( I_f / I_s \right) + (d - 0.5)Z_{1L}I_{sh} / I_s \quad (6)$$

Impedance seen by the relay in case II is higher (6),

than the case I, due to the presence of additional term  $(d-0.5)Z_{1L}I_{sh}/I_s$ . Also, this term is independent of the fault resistance, and it is proportional to the current injected by the STATCOM. Measured impedance will increase whenever the STATCOM is injecting current into the system, causing the relay to under reach. Examining (6), the first term represents the line impedance to the fault point for solid fault with no midpoint shunt compensation. Therefore, the error in the apparent impedance  $Z_{error}$  introduced as a result of the shunt compensation and the fault resistance is given as

$$Z_{error} = R_f \left( I_f / I_s \right) + (d - 0.5)Z_{1L}I_{sh} / I_s \quad (7)$$

From the above analysis it can be observed that the measured impedance will be affected by shunt compensation only for the case II. Therefore, this case requires detailed analysis. Assuming a three phase solid fault at point d of figure 6, we can obtain the reduced equivalent circuit to obtain the impedance measured by the relay ( $Z_m$ ) in the presence of statcom is as shown in the figure 7.

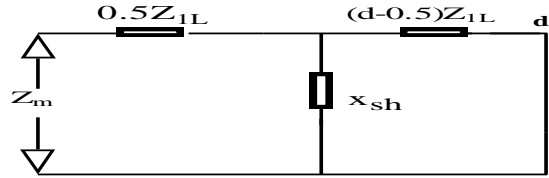

Figure 7. Reduced equivalent circuit during three phase fault at point d.

That is,

$$Z_m = 0.5Z_{1L} + \frac{(d - 0.5)Z_{1L} * X_{sh}}{(d - 0.5)Z_{1L} + X_{sh}} \quad (8)$$

$$Z_m = Z_{1L}d = Z_{nc} \quad (9)$$

Where  $Z_{nc}$  is the impedance when there is no shunt compensation,  $Z_m/Z_{nc}$  will give the comparison between impedance measured with /without shunt compensation for fault location (d). This ratio represents the degree of under/over reaching of the relay. Hence dividing (8) by (9) we get,

$$\frac{z_m}{z_{nc}} = \frac{1}{d} \left[ 0.5 + \frac{(d - 0.5) * X_{sh}}{(d - 0.5) * Z_{1L} + X_{sh}} \right] \quad (10)$$

Assuming lossless line  $Z_{1L} = X_{line}$ , substituting in (10) we get

$$\frac{z_m}{z_{nc}} = \frac{1}{d} \left[ 0.5 + \frac{(d - 0.5) * c}{(d - 0.5) * Z_{1L} + c} \right] \quad (11)$$

Where  $c = X_{sh} / X_{line}$  is the compensation factor. The value of  $c$  will be negative in the case of capacitive

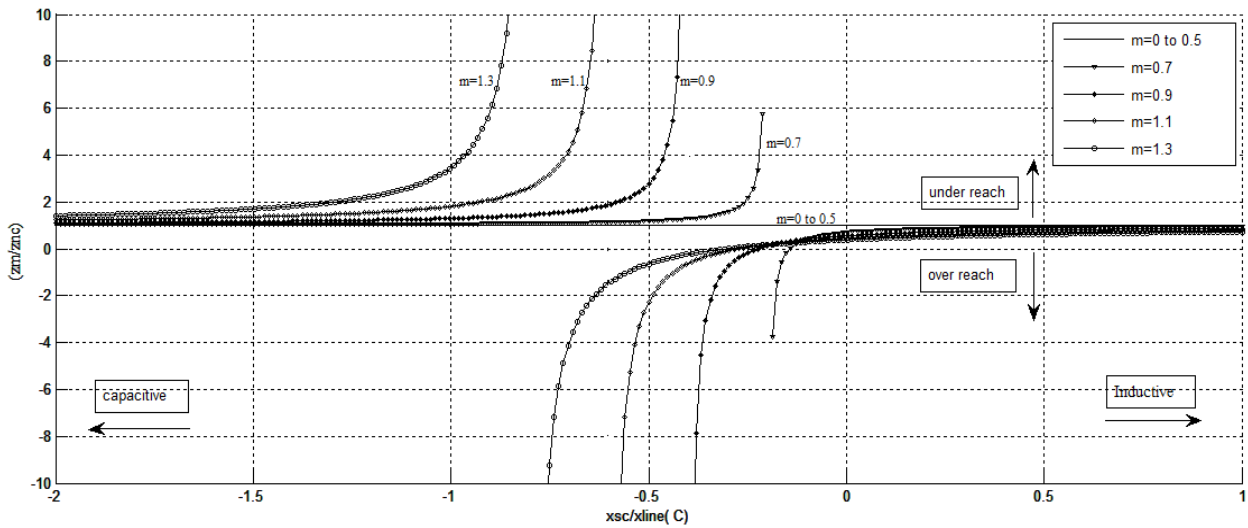

Figure 8. The plot of measured impedance with /without shunt compensation ( $Z_m/Z_{nc}$ ) versus compensation factor.

compensation and positive for inductive compensation. The plot of measured impedance with /without shunt compensation ( $Z_m/Z_{nc}$ ) versus compensation factor ( $c$ ) for different fault location( $d$ ) is as shown in the figure 8.  $d > 1$  denotes faults beyond the protected section of the line. For faults up to 50% of the line  $Z_m/Z_{nc} = 1$  as shown in the figure 8. But for faults beyond 50% of the line, the shunt compensation reactance  $x_{sh}$  of the STATCOM affects the measured impedance. From the figure 8 it can be observed that when  $x_{sh}$  is equal to the reactance of the line between STATCOM installation point and fault location, resonance will occur which is also the point of highest impact. The resonance point divides the curves between over/under reaching regions along Y-axis. From the plot it can be observed that the impact of shunt compensation decreases as compensation factor increases. Also the fault distance on the transmission line has bearing on the relay performance .Possible over/under reaching of the relay increases as the fault location increases from the shunt compensation point.

#### 4. Simulation Results

The systems considered above are simulated for different types of faults at different locations on the transmission line. Also, the effect of placement of STATCOM at different places on line is presented. The distance relay placed at bus M is set to protect 85% of the line. To study the effect of STATCOM a single line to ground fault on phase A at 85% of the line is applied. Figures 9 and 10 shows the RMS voltage at

the mid point and the impedance trajectory without FACTS device connected. Figures 11 and 12 shows the

RMS voltage at the midpoint and the impedance trajectory with STATCOM connected to maintain the midpoint voltage at 1.0 pu.

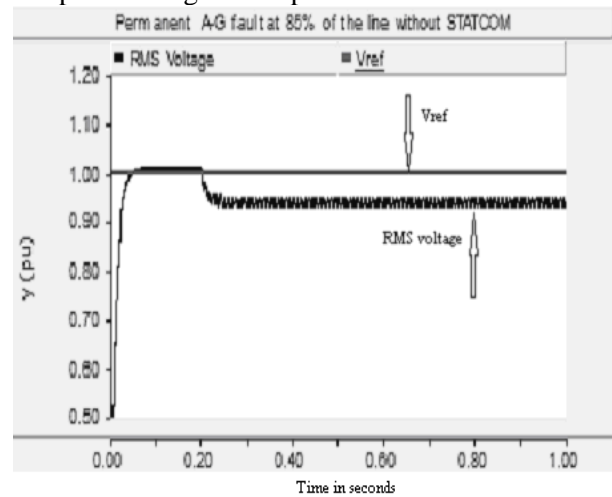

Figure 9. Mid point voltage in the absence of STATCOM

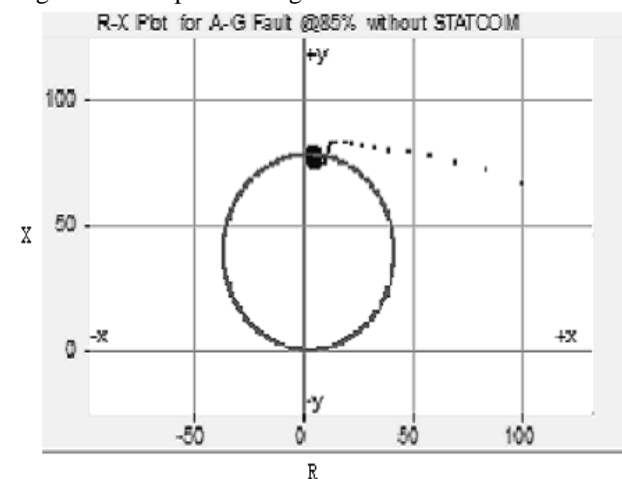

Figure 10. R-X plot in the absence of STATCOM

From the figure 12 it can be seen that the relay will

under reach in the presence of STATCOM. Similar way all types of faults have been created and verified. It was seen that, in all cases relay will under reach. Under reaching of the relay, increases as the fault distance increases and vice versa. A-G fault is applied at 61% of the line, and impedance trajectory is plotted in the figure 13. In this case the under reaching is less severe compared with the fault at 85% of the line. This can be verified by (7), that the error in apparent impedance is directly proportional to the fault distance  $d$ . Also the effect of fault resistance on the relay performance is investigated. In figure 14 simulation results of an A-G fault at 61% of the line with a fault resistance of 10 ohm is presented. It may be seen from the R-X plot that the impedance trajectory settles far away from the mho characteristic boundary. Hence, it can be concluded that, the under reaching tendency aggravates with increase in fault resistance.

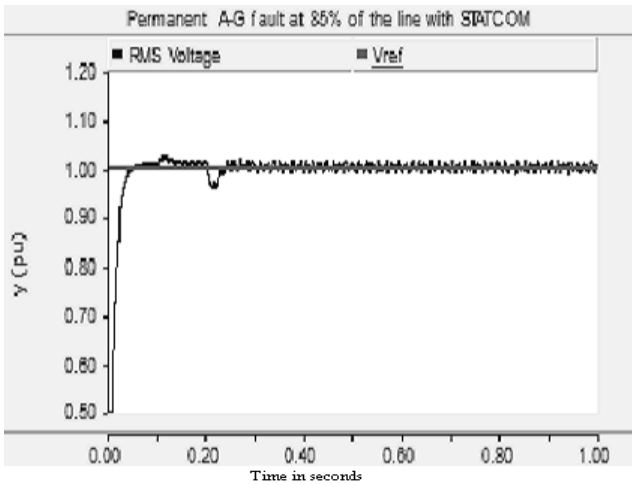

Figure 11. Mid point voltage in the presence of STATCOM

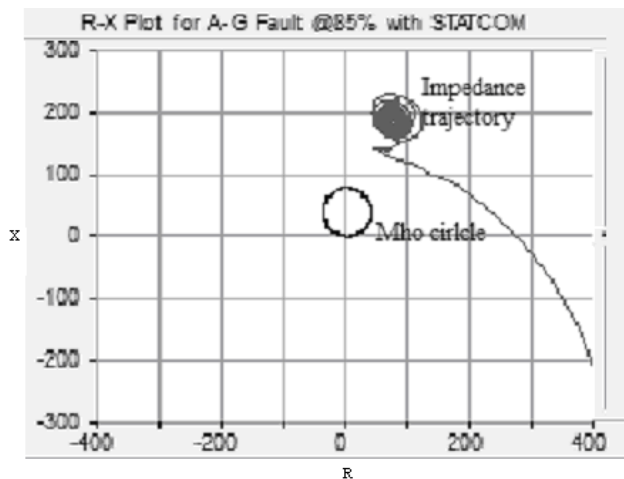

Figure 12. R-X plot in the presence of STATCOM

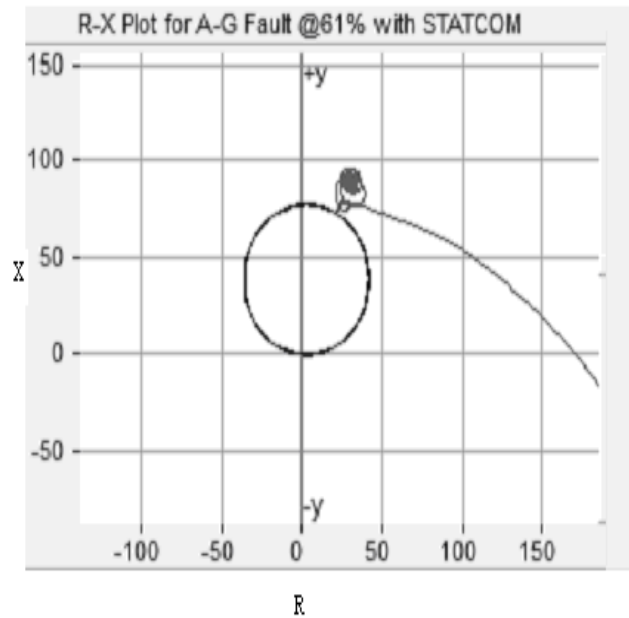

Figure 13. R-X plot in the presence of STATCOM for A-G fault line at 61% of the line.

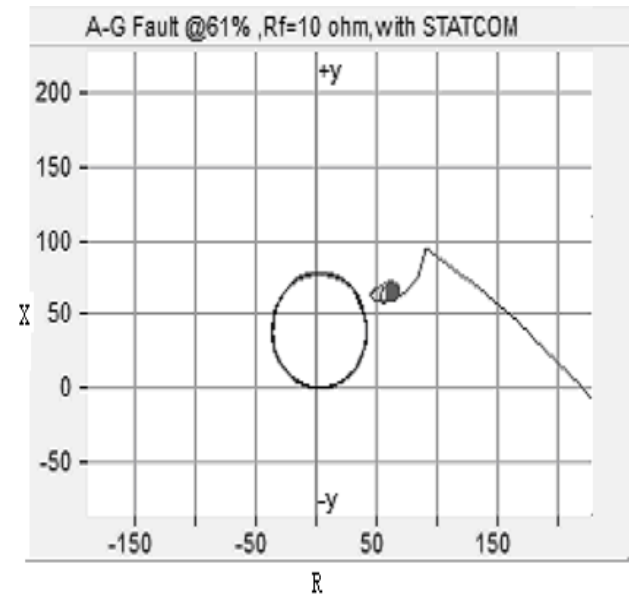

Figure 14. Simulation results of an A-G fault at 61% of the line with a fault resistance of 10 ohm.

Simulations are carried out by placing the STATCOM at the sending end and receiving end of the figure 1. It is found this placement has no effect on the relay operation as the STATCOM is not included in the fault loop. Figure 15 shows the R-X plot of an A-G fault at 85% of the line with STATCOM connected at the sending end. It can be seen that Impedance trajectory settles properly on the mho relay characteristics

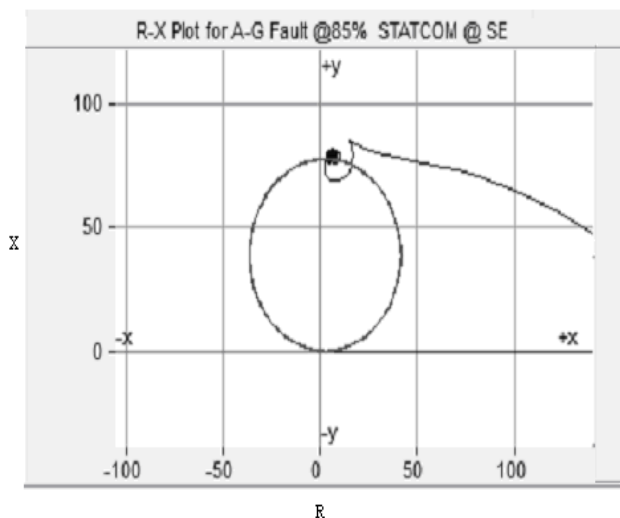

Figure 15. R-X plot in the presence of STATCOM at the sending end for A-G fault at 85% of the line.

## 5. Conclusion.

In this paper the effect of STATCOM based midpoint shunt compensation on the distance relay performance is investigated. A typical power system with a STATCOM connected at the midpoint of the line and a

distance relay are modeled using EMTDC/PSCAD. To make accurate impedance measurement, complex compensation factor is used in the distance relay model. All types of faults are created at different locations on the transmission line. It was observed that the error introduced by the compensation is directly proportional to three factors namely, the fault distance 'd' on the transmission line, shunt device compensation current ' $I_{sh}$ ' and the fault resistance  $R_f$ . For the system studied, it was found that the first zone protection would not see a fault at the reach setting. The action of STATCOM during faults increases the R-X ratio of the transmission line significantly resulting in under reaching of the relay. It was also found that STATCOM connected at sending and receiving ends do not affect the relay performance as it is excluded from the fault loop. Therefore, it is highly desirable to have an adaptive relaying scheme to mitigate the problem of relay maloperation in the presence of FACTS devices.

## Appendix

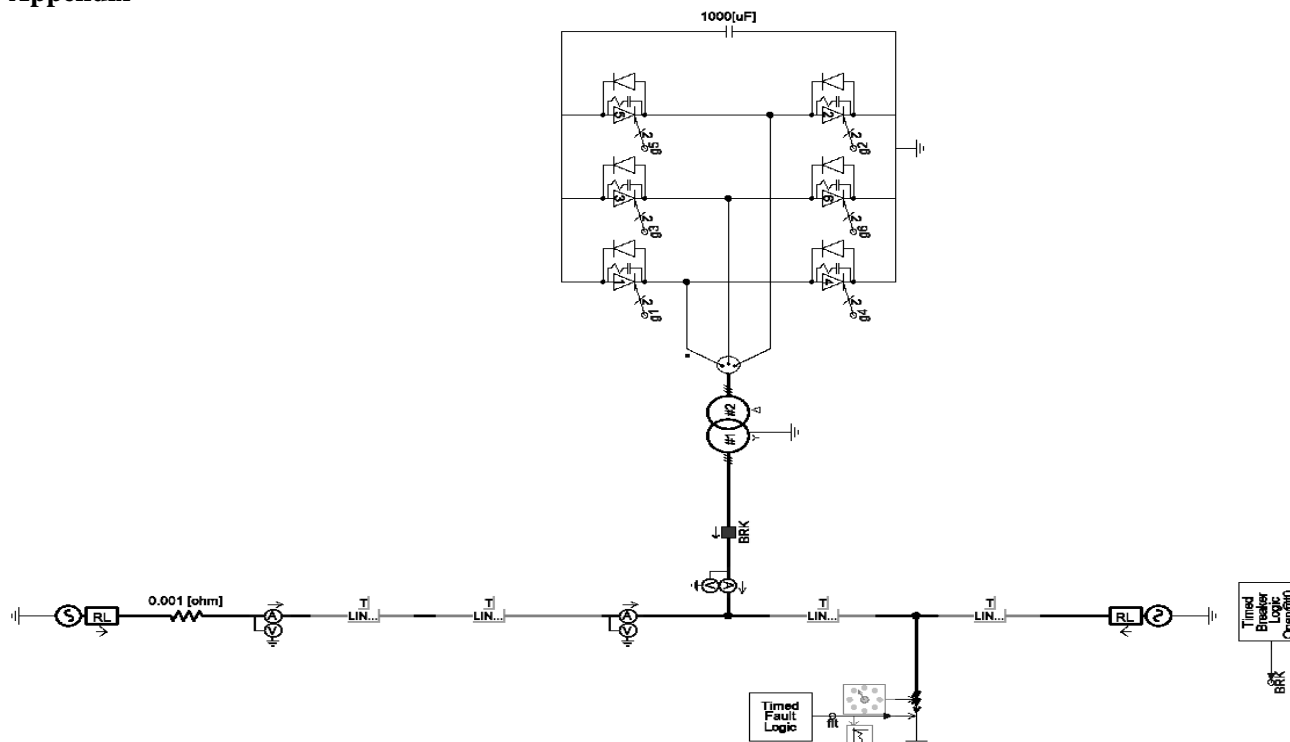

Figure 1. Test system modeled in EMTDC /PSCAD

## References

1. Hingorani N. G. and Gyugy L.: *Understanding FACTS: Concepts & Technology of Flexible AC Transmission Systems*. John Wiley and Sons, New York, United states of

America, 1999.

2. Padiyar K.R.: *FACTS controllers in power transmission and distribution*. New age publishers, New Delhi, India, 2007 .

3. Miller T.J.E.. *Reactive Power Control in Electric Systems*, John Wiley and Sons, New York, United States of America, 1982 .
4. Sanaye-Pasand M., Seyedi H.: *Simulation, a nalysis and setting of distance relays on double circuit transmission lines*. In: Proceedings of the Australasian Universities Power Engineering Conference, 2003, Christchurch, New Zealand, pp.177-183.
5. Kowsalya M, Ray K.K, and Kothari D.P.: *Positioning of SVC and STATCOM in a long transmission line*. In: International Journal of Recent Trends in Engineering, 2009, Vol 2, No. 5, pp.150-154.
6. Khalil El- Arroudi, Geza joos, and Donald T. McGills. 2002.: *Operation of impedance protection relays with STATCOM*. In :IEEE Transactions on power delivery, 2002, VOL 17, NO.2, PP-381-387.
7. LIU Qing, WANG Zeng-ping, ZHAN Yuan.: *Study on a novel method of distance Protection in transmission line with STATCOM*. In: Power and energy Engineering conference (APPEEC) Asia-Pacific , March 28-31, 2010, Chengdu, China, p. 1-5.