

INTEGRATION OF FAULT DETECTION AND DIAGNOSIS WITH CONTROL FOR A THREE-TANK SYSTEM USING ROBUST RESIDUAL GENERATOR

A.Asokan¹ D.Sivakumar¹

¹Department of Instrumentation Engineering, Faculty of Engineering & Technology
Annamalai University, Annamalai Nagar-608 002, Tamilnadu, India
E-mail:asokan_me@yahoo.co.in

Abstract: In this paper an algorithms is developed for fault diagnosis and fault tolerant control strategy for nonlinear systems subjected to an unknown time-varying fault in the presence of modeling error. In this paper, a design procedure for robust residual generators is developed using reference model and optimization criterion, based on robust H_∞ filtering, used to synthesize the residual generator. The fault magnitude and time of occurrence of fault is obtained through a transformation of robust residuals in to structured residuals. The estimated magnitude of the disturbance variable is used by the feed-forward control algorithm to make appropriate changes in the manipulated variable to keep the controlled variable near its set value. The feed-forward controller acts along with feed-back controller to control the multivariable system. The performance of the proposed scheme is applied to a three- tank process for various types of disturbance inputs and modeling errors to show the effectiveness of the proposed approach

Key words: Fault detection, fault estimation, Robust Residual Generation, Structured Residual Approach, fault tolerant controller

1. Introduction

Increasingly faced with the requirements of safety, reliability and profitability, chemical plant operation is relying extensively on highly automated process control systems. Automation, however, tends to also increase vulnerability of the plant to faults, potentially causing a host of economic, environmental, and safety problems that can seriously degrade the operating efficiency of the plant if not addressed within a time appropriate to the context of the process dynamics. Examples include physical damage to the plant equipment, increase in the wasteful use of raw material and energy resources, increase in the downtime for process operation resulting in significant production losses, and jeopardizing personnel and environmental safety. These considerations provide a strong motivation for the development of methods and strategies for the design of advanced fault-tolerant control structures that ensure an efficient and timely response to enhance fault recovery, prevent faults from

propagating or developing into total failures, and reduce the risk of safety hazards.

Recently, fault-tolerant control has gained increasing attention in the context of chemical process control; however, the available results are mostly based on the assumption of a linear process description [6, 7] and do not account for complexities such as control constraints or the unavailability of state measurements. In process control, given the complex dynamics of chemical processes (example, nonlinearities, uncertainties and constraints) the success of any fault-tolerant control method requires an integrated approach that brings together several essential elements, including: (1) the design of advanced feedback control algorithms that handle complex dynamics effectively, (2) the quick detection of faults, and (3) the design of supervisory switching schemes that orchestrate the transition from the failed control configuration to available well-functioning fallback configurations to ensure fault-tolerance.

Diagnosis and supervision are important in many applications. Different approaches for fault detection using mathematical models have been developed in the last 20 years. The task consists of the detection of faults in the processes, actuators and sensors by using the dependencies between different measurable signals. They are based either on the model of the system [2, 3, 4, 5] or on the knowledge about the system [6, 7]. One way to detect faults in a system is by means of analytical redundancy [8, 9]. This consists of comparing the behaviour of the real system and the behaviour of a model of the system. In an ideal case, the system and the model behave exactly the same and a fault is detected when the behaviours are different, but usually there are differences between the behaviours of the system and the model.

Figure1 shows the implementation procedure of

the proposed scheme. When there is a fault in the process, the process output differs with model output. This difference is called residual. By simply monitoring the residuals one can say that something is going wrong. But it is not possible to identify the location and magnitude of the fault. So the residual has to be processed to enhance isolation. After processing by SRA the fault magnitude is found and it is used to reconfigure the controller.

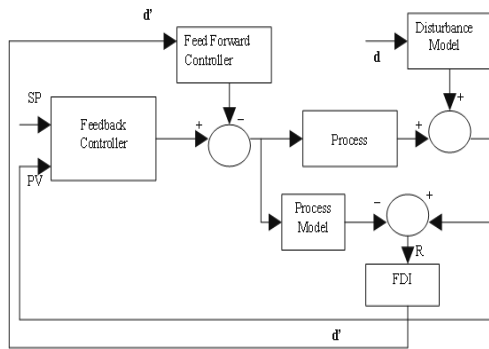

Figure 1. Implementation of proposed scheme

This paper is organized as follows. In section 2 the problem is formulated. In section 3, 4&5 the robust residual method is explained. In section 6 the system under study i.e. three-tank system is described. In section 7, the identification of un-measured disturbance variables (faults) using structured residual approach as reported in literature is explained. The proposed scheme to control in the presence of unmeasured disturbance acting on the process is presented in section 8. In section 9 the simulation results are discussed. And the real time analysis is given in section 10. Finally the conclusions are drawn and scope of further work is provided in section 11.

Model based diagnosis uses a model to obtain residuals, which are signals that are zero in the fault free case and non-zero otherwise, to perform the diagnosis. Since available models of real processes always are uncertain, there is naturally a need for robust methods minimizing the sensitivity to the model uncertainties. This paper addresses the problem of synthesizing and analyzing robust residual generators in the presence of parametric uncertainties that influence the process. Here, focus is on designing robust residual generators, dealing with model uncertainty, to fit in a structured residuals framework. A main observation here is that, for this purpose, it is advantageous to introduce a reference model that

describes desired behavior of the residuals with respect to faults.

2. Problem Formulation

The system under consideration is assumed to be on the form

$$Y = G^\Delta(s)u + L^\Delta(s)f \quad (1)$$

Where y is the measurement vector, u the control signal, and f is the fault vector, matrices $G^\Delta(s)$, and $L^\Delta(s)$ are all rational transfer matrices. The superscripts Δ indicates that the model is subject to bounded parametric uncertainties. The residual generator is a finite dimensional linear filter $Q(s)$ that uses available known signals, that is Y and u , to form a vector of residuals r that can be used to detect and isolate the different faults f .

$$r = Q(s) \begin{pmatrix} Y \\ u \end{pmatrix} \quad (2)$$

The basic requirement on $Q(s)$, besides being RH_∞ , is that the residuals, r , should also be insensitive to control actions u , but it should be sensitive to faults f . The technique of fault isolation considered here is structured residual approach where faults are decoupled in each residual. By generating a set of residuals where different subsets of faults are decoupled in each residual, fault isolation is possible. Inserting (1) into (2) gives

$$r = Q(s) \begin{bmatrix} G^\Delta(s) \\ 0 \end{bmatrix} u + Q(s) \begin{bmatrix} L^\Delta(s) \\ 0 \end{bmatrix} f \quad (3)$$

Nominally, to achieve decoupling of u the first term of (3) must be zero while the second term must be $\neq 0$. However, with uncertain models it is in most cases impossible to get the first term = 0 for all Δ i.e. for all possible instances of uncertainties, without losing some or all of the desired fault sensitivity. Generally some tradeoff between sensitivity to faults and uncertainty attenuation is required. The problem studied here is how to find the filter $Q(s)$ such that a proper trade off between fault sensitivity and robustness towards model uncertainty is achieved. The solution is based on a performance specification described in Section 3 and a synthesis procedure based on robust H_∞ -filtering described in Section 4.

3. Reference Model

When synthesizing a robust residual generator, it is desired that the design freedom available should be used to achieve both robustness and detection

performance. It is chosen that a reference model, $R(s)$, to describe the desired behavior of the residual vector r , with respect to faults f . Define desired residual behavior $r_0(s)$, of the residual, via the reference model as

$$r_0(s) = R(s)f(s)$$

The matrix $R(s)$ is an arbitrary RH_∞ transfer matrix of appropriate dimensions. It is of course necessary that the reference model, $R(s)$, contains the necessary structure for $Q(s)$ to be a residual generator. This includes decoupling properties of faults, i.e. zeros at proper positions in $R(s)$ corresponding to the desired residual structure

4. Robust Residual Generator Synthesis

The main idea with robust residual generation is to minimize the unwanted influences on the residuals while maintaining the fault sensitivity in the residuals. This trade-off, fault sensitivity vs. disturbance attenuation, is normally formulated as an optimization problem in different formulations and norms[14-20]. A common choice is to utilize H_∞ theory to perform the synthesis. Powerful synthesis tools are important, but also worst-case analysis tools are important to aid example robust threshold selection or robustness evaluation.

4.1 Robustness Criterion

The optimization criterion used here is formulated as a robust H_∞ filtering problem [13].

The criterion is given by

$$J = \sup_{v \in L} \frac{\|r_0 - r\|_2}{\|v\|_2} \quad (4)$$

where $v = [u^T f^T d^T]^T$. The optimization criterion J is thus the worst case distance between the residual r and the idealized residual r_0 , defined by transfer matrix $R(s)$, normed by the size of the inputs. The optimal residual generator $Q(s)$ is the filter that minimizes J for all $\|\Delta\|$ inside some bounded ball.

The optimization criterion J can be rewritten as

$$J = \sup_{v \in L} \frac{\|r_0 - r\|_2}{\|v\|_2} = \sup_{v \in L} \frac{\|T_{zv}(s)v\|_2}{\|v\|_2} = \|T_{zv}(s)\|_\infty$$

Where $z(t) = r_0(t) - r(t)$, and

$$T_{zv} = [-G_{ru}^\Delta(s)(R(s) - G_{rf}^\Delta(s))] \quad (5)$$

is the transfer matrix from $v(t)$ to $z(t)$. The transfer matrices from u to r , $G_{ru}(s)$, and from f to r , $G_{rf}(s)$ all depend on the residual generator $Q(s)$. Minimizing J , i.e. minimizing the 1-norm of expression (5), has a simple interpretation, the first makes sure that the influence from u on the residual are attenuated. The

next term keeps fault sensitivity, and also shapes the fault to residual transfer function $G_{rf}(s)$ by minimizing the distance to the reference model $R(s)$.

The optimization performance index minimizes the absolute difference between $R(s)$ and $G_{rf}(s)$. A reasonable assumption is that it is the relative difference that needs to be minimized, otherwise in high-gain models even very small relative errors will dominate the loss function and therefore move away optimization focus from robustness to fault sensitivity in an unwanted manner. Therefore it is important to normalize and weigh the model appropriately to avoid such effects.

4.2 Implementation

The residual generation optimization problem can be described by an upper and lower LFT, including the structured parametric uncertainty, as in Figure 1, where $P(s)$ is an augmented system description including a description on how the parametric uncertainties Δ influence the system, fault models, disturbance models, dynamic weighting matrices and also the reference model. With this problem setup, there exist algorithms minimizing J with respect to $Q(s)$ by example μ synthesis. The algorithm used in this work is basic DK-iterations.

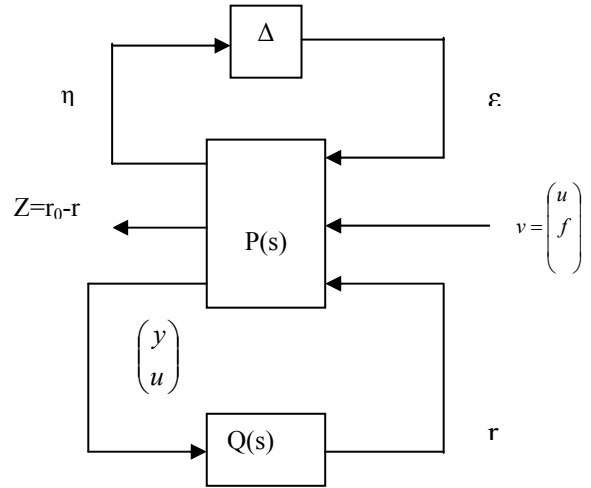

Figure2. LFT formulation of residual generation problem

5. Forming the Reference Model

Reference model with unrealistic performance properties, can result in a residual generator with unnecessary poor robustness properties. The main idea is thus to use a nominal design of the residual generator to shape the reference model when synthesizing the robust residual generator, thus assuring attainable reference models. This is to avoid

specifying an unrealistic performance criterion and thereby inflicting unnecessary poor robustness properties on the residual generator. The formation of the criterion for the robust design is straightforward, given that a nominal residual generator, i.e. a $Q_{nom}(s)$, has been derived that nominally fulfills all demands. The reference model $R(s)$ is then selected as

$$R(s) = Q_{nom}(s) \begin{bmatrix} L(s) \\ 0 \end{bmatrix} \quad (6)$$

Since this is the nominal fault to residual transfer function, compare with Equation (3). Of course, if no design based on a nominal model is available that meets the requirements of the application, then no feasible design with an uncertain model is available either.

6. System Descriptions

The three-tank system considered for study [6] is shown in Figure 2. The controlled variables are the level of the tank1 (h_1) and level of the tank3 (h_3). In flow of tank1 (fin_1) and in flow of tank3 (fin_3) are chosen as manipulated variables to control the level of the tank1 and tank3. The unmeasured outflow of that is leak of tank1, tank2 and tank3 have been considered as fault variables (L_1, L_2 and L_3). In this paper it is assumed that the leaks are independent of level of the tank.

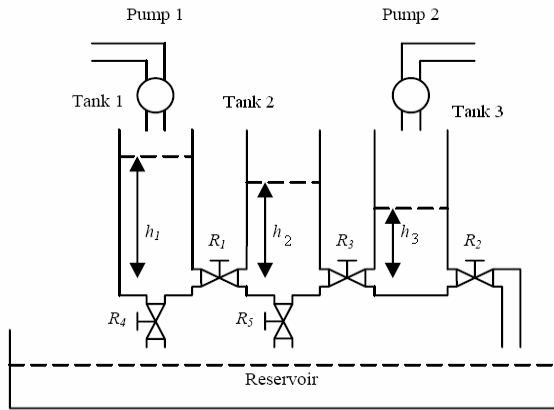

Figure 3. Schematic diagram of three Tank System

To find the material balance for the three-tank system first let us consider tank1.

$$\begin{bmatrix} \text{Rate of change of mass} \\ \text{of water in tank 1} \end{bmatrix} = \begin{bmatrix} \text{Mass flow Rate of water} \\ \text{into the tank1} \end{bmatrix} - \begin{bmatrix} \text{Mass flow Rate of water} \\ \text{out of the tank1} \end{bmatrix}$$

$$\frac{d\rho A_T h_1}{dt} = \rho fin_1 - \rho fout_1 \quad (7)$$

$$fout_1 = b_1 \sqrt{h_1 - h_2} \quad (8)$$

Substituting equation (8) in equation (7)

$$\rho A_T \frac{dh_1}{dt} = \rho fin_1 - \rho b_1 \sqrt{h_1 - h_2} \quad (9)$$

Dividing the equation (5.3) throughout by A_T

$$\frac{dh_1}{dt} = \frac{fin_1}{A_T} - \frac{b_1}{A_T} \sqrt{h_1 - h_2} \quad (10)$$

Similarly from the material balance equations of tank2 and tank3, we get

$$\frac{dh_2}{dt} = \frac{b_1 \sqrt{h_1 - h_2}}{A_T} - \frac{b_2 \sqrt{h_2 - h_3}}{A_T} + d_2 \quad (11)$$

$$\frac{dh_3}{dt} = \frac{b_2 \sqrt{h_2 - h_3}}{A_T} - \frac{fin_3}{A_T} - \frac{b_3 \sqrt{h_3}}{A_T} \quad (12)$$

where $b_1 = C_1 Sp \sqrt{2g}$; $b_2 = C_2 Sp \sqrt{2g}$ and $b_3 = C_3 Sp \sqrt{2g}$

when C_1, C_2, C_3 are constant flow coefficients

Sp = Area of cross section of connecting pipe.

A_T = Area of the tanks 1, 2 and 3.

g = Acceleration due to gravity.

To develop the state space model of the form.

$$\dot{X} = AX + BU \quad (13)$$

$$Y = CX \quad (14)$$

$$\text{where } X = \begin{bmatrix} h_1 \\ h_2 \\ h_3 \end{bmatrix} \text{ and } U = \begin{bmatrix} fin_1 \\ fin_3 \end{bmatrix}$$

The linear time invariant state space model elements are obtained as follows:

$$A_{ij} = \frac{\partial \bar{f}_i}{\partial \bar{X}_j} \Big|_{\bar{x}, \bar{u}} \quad (15)$$

$$B_{ij} = \frac{\partial \bar{f}_i}{\partial \bar{U}_j} \Big|_{\bar{x}, \bar{u}} \quad (16)$$

$$C_{ij} = \frac{\partial \bar{g}_i}{\partial \bar{U}_j} \Big|_{\bar{x}, \bar{u}} \quad (17)$$

$$D_{ij} = \frac{\partial \bar{g}_i}{\partial \bar{U}_j} \Big|_{\bar{x}, \bar{u}} \quad (18)$$

Hence

$$\dot{x} = Ax + Bu$$

$$y = Cx + Du$$

Where

$$A = \begin{bmatrix} -0.00723996 & 0.00723996 & 0 \\ 0.00723996 & -0.01707086 & 0.0098303 \\ 0 & 0.0098309 & -0.012540553 \end{bmatrix}$$

$$B = \begin{bmatrix} 64.935 & 0 & 0 \\ 0 & 64.935 & 0 \\ 0 & 0 & 64.935 \end{bmatrix}$$

$$C = \begin{bmatrix} 1 & 0 & 0 \\ 0 & 1 & 0 \\ 0 & 0 & 1 \end{bmatrix}$$

$$D = \begin{bmatrix} 0 & 0 & 0 \\ 0 & 0 & 0 \\ 0 & 0 & 0 \end{bmatrix}$$

When fault (leak) occurs the state space model is given by

$$\dot{x} = Ax + Bu + B_f f$$

$$y = Cx + Du$$

$$B_f = \begin{bmatrix} 64.935 & 0 & 0 \\ 0 & 64.935 & 0 \\ 0 & 0 & 64.935 \end{bmatrix}$$

Table.1 Steady state operating data

h1, h2,h3 in m	0.7,0.5,0.3
fin ₁ and fin ₃ in ml/sec	100
Outflow coefficient(Az1,Az2,Az3)	2.251e-5,3.057e-5,2.307e-5
Area of tank (S1-S3)in m ²	0.0154
L ₁ ,L ₂ ,L ₃ in ml/sec	0
Acceleration due to gravity in m/sec ²	9.81

7. Design of Structured Residual Generator

To transform raw residual R(s) into structured form R_t(s), multiply R(s) with weighting matrix W(s)

$$R_t(s) = W(s)R(s) \quad (19)$$

Weighting matrix is chosen as to contain inverse of

Identified fault model to cancel the effects of fault transfer function present in residual.

$$W(s) = Z(s)G_F^{-1}(s) \quad (20)$$

Where Z(s) is user defined matrix

Substituting W(s) in expression (19)

$$R_t(s) = [Z(s)G_F^{-1}(s)][R(s)]$$

Substituting R(s) in the above expression

$$R_t(s) = [Z(s)G_F^{-1}(s)][G_F(s)L(s)]$$

$$R_t(s) = Z(s)IL(s) \quad (21)$$

Where I is the identity matrix.

$$R_t(s) = Z(s)L(s) \quad (22)$$

Z(s) is chosen as diagonal matrix so as to fault estimation

8. Integration of Fault detection And Isolation with Control

The synthesis method [8] is used for the design of feedback PI controllers. The PI controllers are designed so that the closed loop process behaves like a first order system with unity gain and time constant same as the open loop time constant. The resulting parameter for controlling the height of tank1 using the inflow of tank1 is given by K_c = 2.54e-04 (ml/sec/m) and T_i=222 seconds and that of tank3 using the inflow of tank3 is given by K_c = 7.69e-04 (ml/sec/m) and T_i=200 seconds. The process is simulated using the non-linear first principles model, whereas the FDI is based on the time invariant linearized model (Transfer function model).

The proposed feed-forward –feedback control scheme is shown in Figure.1. The proposed scheme makes use of structured residual based fault detection and identification proposed by Gertler [1] for detection, isolation and estimation of unmeasured disturbances acting on the process. The estimated magnitude of the disturbance variable is given to the feed-forward control algorithm, which makes appropriate changes in the manipulated variable to keep the controlled variable near its set value. The feed-forward controller is used along with feed-back controller to control the multivariable system. Hence, the feedback controller has much less work to do to compensate for disturbance. It should be noted that the disturbance is detected as it enters the process and immediate corrective action is taken to compensate for its effect on the process. It is well known that design of feed-forward controller depend on the models for the disturbance and the process (Marlin, 1995) and is given by

$$G_{ff}(s) = \{G_d(s) / G(s)\} \quad (23)$$

The disturbance ($G_d(s)$) and process model ($G(s)$) in equation (23) is obtained by linearising the non-linear differential equations of the given system around the nominal operating point and taking Laplace transform. It is assumed that the given system under study can be modeled using first principles approach. However, identified models can also be used. Using the closed loop control u_1 , u_2 and the residual estimation, define a fault-tolerant control by

$$u_1^{[FTC]} = u_1 + ua_1$$

$$u_2^{[FTC]} = u_2 + ua_2$$

where

- u_1 , u_2 are output of feedback controller
- The additive control variables ua_1 , ua_2 are defined by

$$ua_1 = -str_1, ua_2 = -str_3$$

9. Simulation Results

The performance of the proposed scheme has been demonstrated on a three-tank interacting system through simulation. The controlled variables are the level of tank1 (h_1) and tank3 (h_3). Inflow of tank1 (fin_1) and tank3 (fin_3) are chosen as manipulated inputs. The leak in tank1 (D_1), leak in tank2 (D_2) and leak in tank3 (D_3) are considered as disturbance variables. Sample time of one second is chosen throughout the simulation. Modeling error of 20 % change in time constant of the system is considered throughout the work. The results are compared with conventional scheme which uses ordinary residual generator

The closed loop behavior of the process with proposed control (using robust residual) scheme when a leak of magnitude 50ml/sec introduced at time $t=3000$ seconds in tank1 is obtained and compared with the performance when employing conventional method in Figure 3.

Regulatory response of the system by implementing the proposed scheme when leak occurs simultaneously in all the three-tanks is obtained and compared with the conventional method is shown in Figure 4. To simulate leak simultaneously in all the three tanks, step disturbance of magnitude 50ml/sec is provided in tank1 at time $t=3000$ sec and in tank2 at $t=5000$ sec where for tank 3 step change of 100 ml/sec is given at $t=7000$ sec.

Further the effectiveness of proposed scheme is tested for slope fault. Disturbance is introduced as a ramp starting with zero magnitude at $t=4000$ seconds and reaching a maximum value of 100 ml/sec at $t=5000$ seconds. The disturbance is then made to

remain constant up to time $t=6000$ seconds. At $t=6000$ sec, the disturbance is made to reach zero at $t=8000$ sec as a negative ramp. From the Figure6 it is evident that even for faults varying as a slope(ramp),the proposed scheme outperform the conventional scheme .

Tank1 in the three tank interacting process is then subjected to a periodical disturbance which is a sinusoidal wave starting at $t=3000$ sec having a 50ml/sec peak value and a period of 200sec. The proposed control scheme is then implemented on this process and the responses are obtained. The comparison of the performance of the system when employing proposed method and conventional technique is made. This reveals that ever for periodical disturbance the proposed method provide better performance as indicated in figure7.

Further the effectiveness of proposed scheme is tested other modelling parameter error. Modeling error of 10 % change in system gain of the system is considered.

The closed loop behavior of the process with proposed control (using robust residual) scheme when a leak of magnitude 50ml/sec introduced at time $t=5000$ seconds in tank1 by sudden opening of the hand valve available in tank. is obtained and compared with the performance when employing conventional method in Figure 7.

10. Real time implementation

The proposed scheme is implemented in real time in three tank system available in the lab. Its nominal parameters are given in table1 which are considered for simulation also.

The proposed scheme is tested for modeling error of 20 % change in time constant of tank1 is considered. First model of the system is obtained by taking open loop data. Then the model is validated .once the model is validated then the modelling error is introduced to test the proposed scheme. The results are compared with conventional scheme which uses ordinary residual generator. The closed loop behavior of the process with proposed control (using robust residual) scheme when a leak of magnitude 50ml/sec introduced at time $t=1000$ seconds in tank1 is shown in figure 9.

The performance of the system when employing conventional method is shown in Figure 10. From these figures one can infer that for modelling errors the proposed method works satisfactorily.

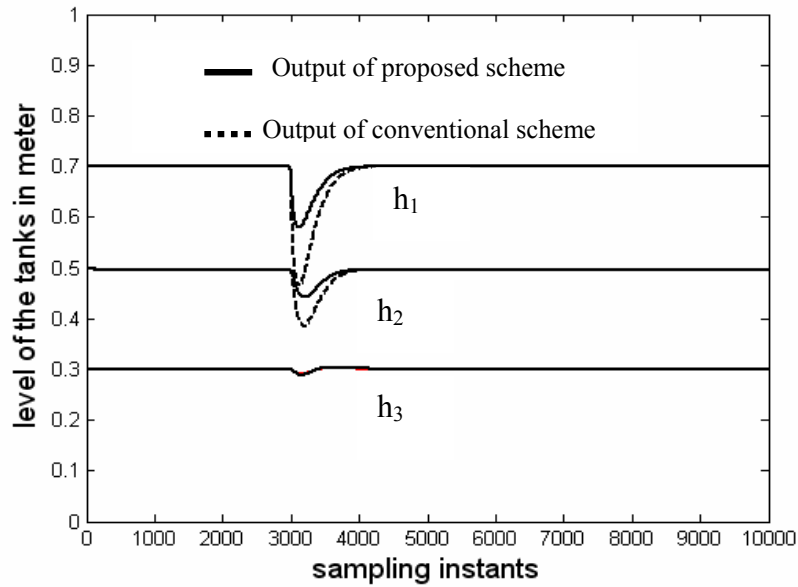

Figure.3 Comparison of Closed loop response of the proposed scheme with conventional control when a leak of magnitude 100ml/sec occurs in tank1 at t=3000sec

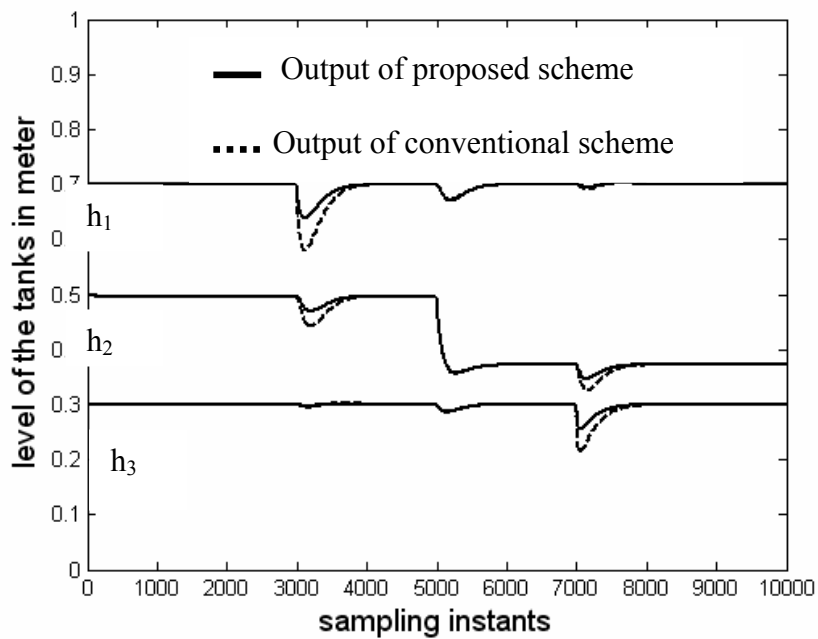

Figure.4 Comparison of Closed loop response of the proposed scheme with conventional control when a leak of magnitude 100ml/sec occurs in tank1 at t=3000sec, a leak of magnitude 50ml/sec occurs in tank2 at t=5000sec and a leak of magnitude 50ml/sec occurs in tank3 at t=7000sec.

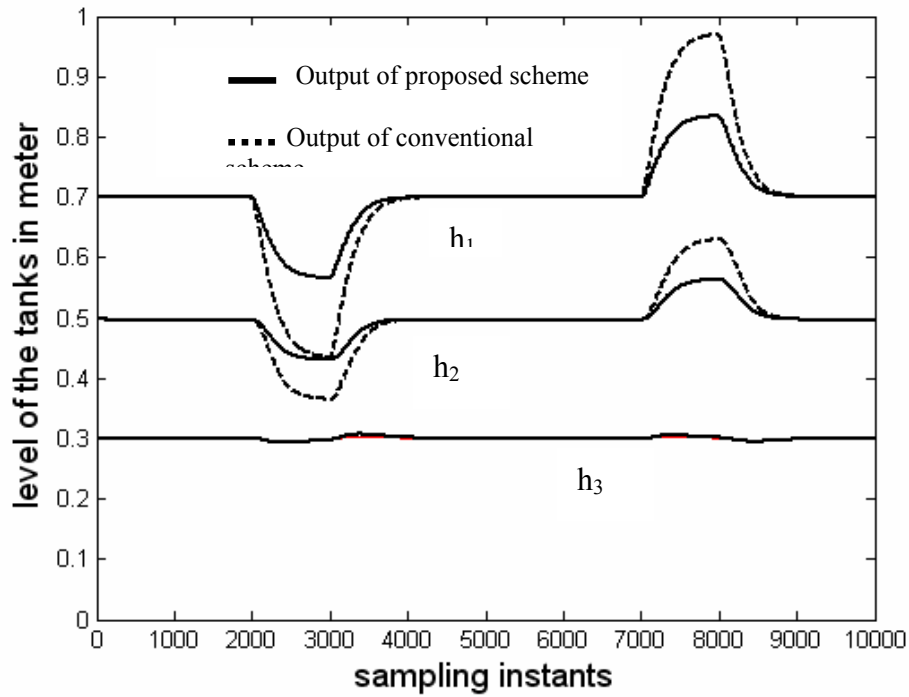

Figure.5 Closed loop response of the System when a leak of varying magnitude (ramp) 100ml/sec occurs in tank1 at $t=3000$ sec to $t=8000$ sec

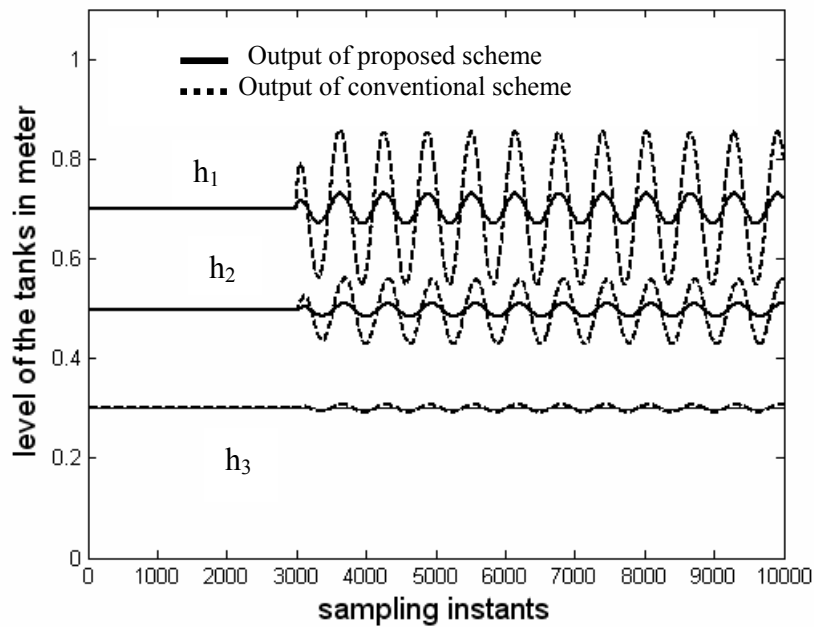

Figure.6 Comparison of Closed loop response of the proposed scheme with conventional control when a periodical disturbance occurs in tank1 at $t=3000$ sec

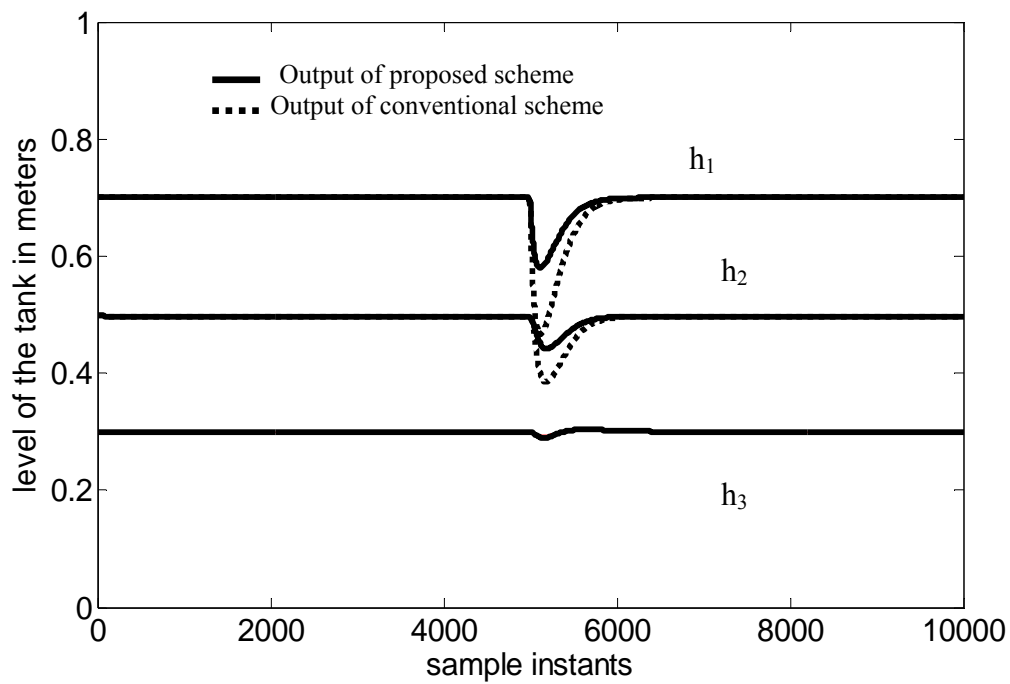

Figure.7 Comparison of Closed loop response of the proposed scheme with conventional control when a leak of magnitude 50ml/sec occurs in tank1 at t=5000sec



Figure 8.Real time three tank system

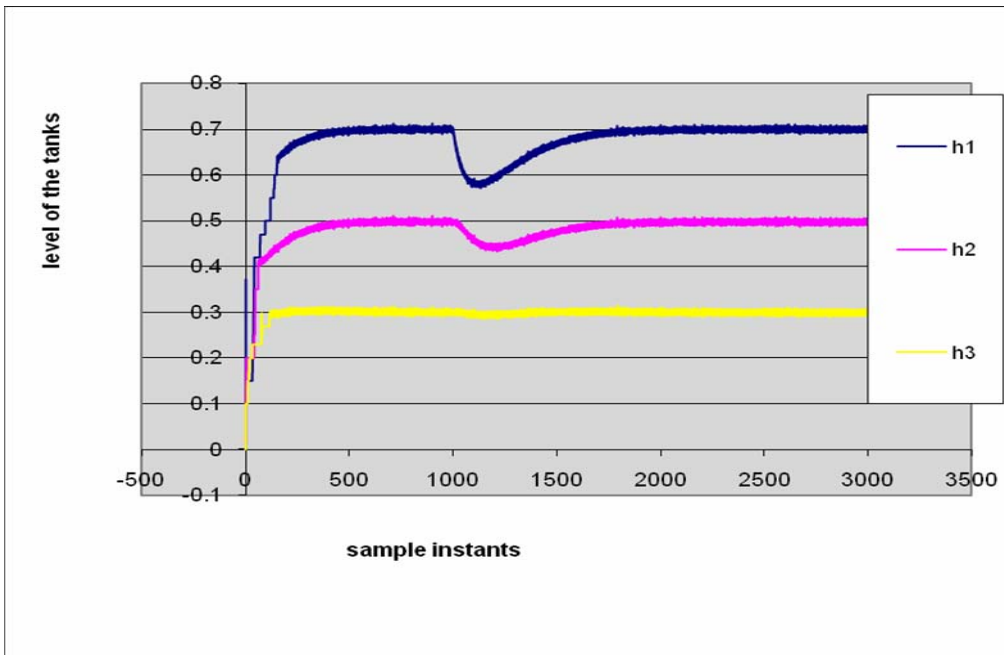

Figure.9 Real time Closed loop response of the proposed scheme when a leak of magnitude 100ml/sec occurs in tank1 at t=1000sec

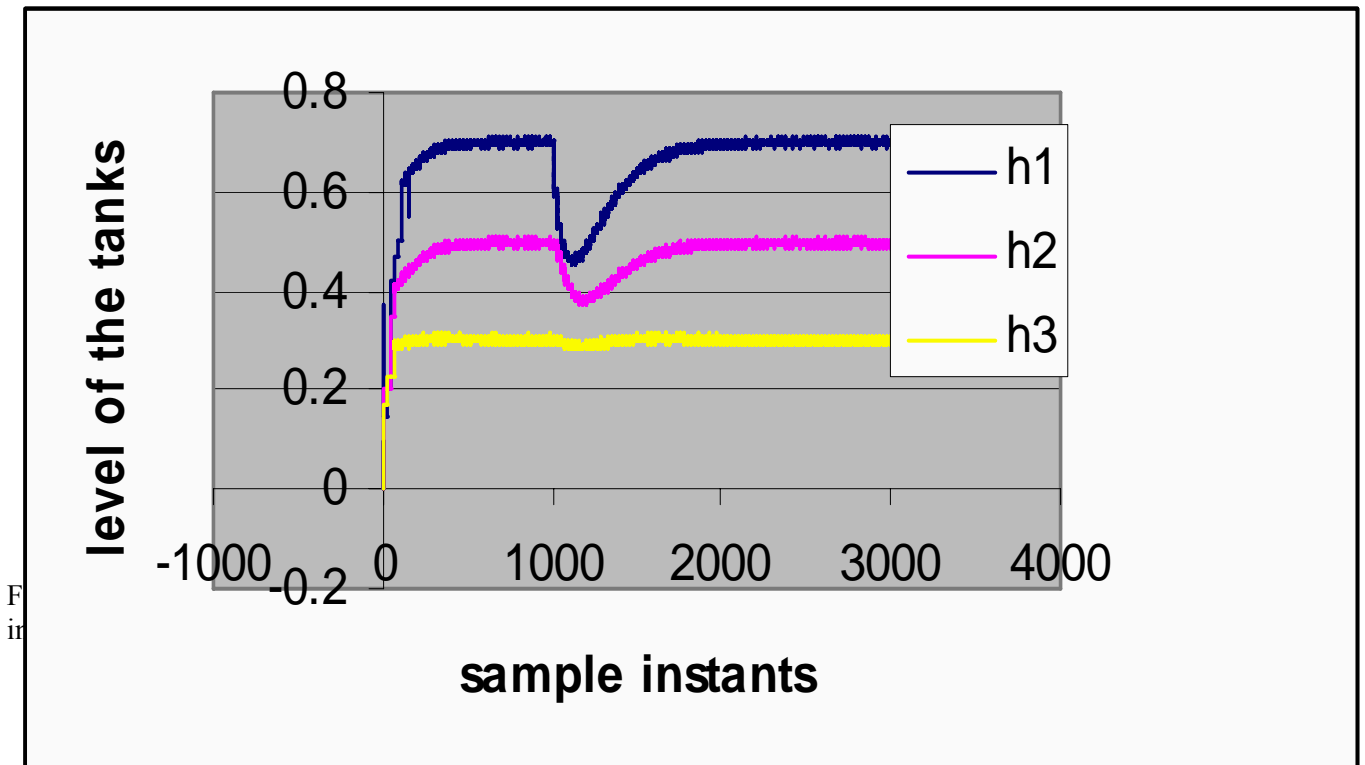

Figure10. Real time Closed loop response of the proposed scheme when a leak of magnitude 100ml/sec occurs in tank1 at t=1000sec

11. Conclusions

The performance of the proposed scheme has been evaluated on a three-tank process for disturbance in the tanks. The proposed scheme can provide disturbance information even when there is modeling error. From the simulation study, it can be concluded that if the estimated magnitude of the disturbance variable (fault) is close to the true value even though the modeling error present. From the results it is also found that the proposed method works better than conventional scheme (without robust residual approach). From the results it is also inferred that the proposed method can identify and isolate the slope disturbance and periodical disturbance quickly. From the simulation results, when compared to conventional scheme the proposed scheme (using robust residual approach) is always gives better performance for various types of disturbance inputs.

References

- [1]. Gertler, J *Fault Detection of Dynamical Systems*, Marcel Dekker, Inc. USA.
- [2]. Gertler, J., Staroswiecki, M. and Shen, *Direct design of structured residuals for fault diagnosis in linear systems*. American Control conference, Anchorage, Alaska, May 2002.
- [3]. Frank, P. M. and Ding, X., *Survey of robust residual generation and evaluation methods in observer-based fault detection systems*, Journal of Process Control, 7(6), pp. 403-424, (1997)
- [4]. R..J.Patton. Fault-tolerant control systems: The 1997 situation. In *Proceedings of the IFAC Symposium SAFEPROCESS 1997*, pp 1033-1054, Hull, United Kingdom, 1997
- [5]. M. Blanke, R. Izadi-Zamanabadi, S. A. Bogh, and C. P. Lunau. Fault-tolerant control systems - a holistic view. *Control Engineering Practice*, pp 693-702, 1997.
- [6]. Zhang, Y. M., and Jiang, J., "Design of Integrated Fault Detection, Diagnosis and Reconfigurable Control Systems," *Proceedings of the 38th IEEE Conference on Decision and Control*, Inst. of Electrical and Electronics Engineers, New York, pp. 3587–3592, 1999.
- [7]. J. Wu, G. Biswas, S. Abdelwahed, and E Manders. *A hybrid control system design and implementation for a three tank testbed*. In *Proceedings of the 2005 IEEE Conference on Control Applications*, pp 645–650, August 2005.
- [8]. Jiang J, Zhao Q. Fault tolerant control system synthesis using imprecise fault identification and reconfiguration control. In *Proceedings of the IEEE International Symposium on Intelligent Control*, Gaithersburg, MD, pp 169-174, September 1998.
- [9]. Chen J, Patton RJ, Chen Z. An LMI approach to fault-tolerant control of uncertain systems. In *Proceedings of the IEEE International Symposium on Intelligent Control*, Gaithersburg, MD, September 1998; pp 175-180.
- [10]. P. Mhaskar, A. Gani, N. H. El-Farra, C. McFall, P. D. Christodes, and J. F. Davis. Integrated fault-detection and fault-tolerant control for process systems. *AIChE Journal*, pp 2129-2148, 2006.
- [11]. P. Mhaskar, C. McFall, A. Gani, P. D. Christodes, and J. F. Davis. Fault-tolerant control of nonlinear systems: Fault detection and isolation and controller reconfiguration. In *Proceedings of the American Control Conference*, pp 5115-5122, Minneapolis, Minnesota, 2006.
- [12]. Karlsruhe, Germany, . Patton RJ. Fault-tolerant control: the 1997 situation. In *Proceedings of IFAC Symposium SAFEPROCESS197*, Hull, U.K. pp 1033-1055, August 1997