

IDENTIFYING THE FAULT LOCATION IN DISTRIBUTION FEEDERS WITH OPTIMALLY PLACED PMU'S

ANEESH RAJEEV, Dr. BINU BEN JOSE D. R.

School of Electrical Engineering (SELECT)

Vellore Institute of Technology

Chennai, Tamil Nadu, India

aneesh.rajeev@gmail.com

Abstract: Phasor measurement units (PMUs) placed in various nodes of power system network facilitates several tasks including optimum power flow, system control, contingency analysis, fault detection etc. For the above purposes, PMU's are not required to place in all the bus in a power system. Also because of higher cost, optimal placement of PMU's are done by using the binary search algorithm. The algorithm for optimal placement is tested for standard IEEE 7, 14 & 30 bus systems. Once the PMU's are placed optimally, the next step involved is the fault location and diagnosis scheme which is capable of accurately identifying the location of a fault upon its occurrence. Two different algorithms has been developed for ring and radial type distribution feeders. These proposed algorithms are tested for different faults on both radial and ring power distribution systems. The scheme is capable of giving results within 98 % accuracy of the line length.

Key words: PMU, Synchrophasors, Distribution Network, Ring feeder, Radial feeder, MiPower, Fault location, Optimal Placement.

1. Introduction

The commercialization of the global positioning system with accuracy of timing pulses in the order of one microsecond has made possible the commercial production of PMU's. The PMU is a power system device capable of measuring voltage and current phasor in a power system. PMU which use synchronization signals from the global positioning system (GPS) satellites and provide the phasors of voltage and currents measured at a given substation [4].

Placing PMUs on every bus of a power system immediately results in a completely observed system. However, since a bus is observed if a PMU is installed on it or on one or some of its neighbouring buses, it is neither necessary nor economical to carry out such full installations. As a result, a problem, named optimal PMU placement (OPP) problem, has been raised [5]. The placement of a minimal set of phasor measurement units to make the system measurement model observable is one of the objectives of this paper. For placing the PMU's, binary search algorithm is used [5][6].

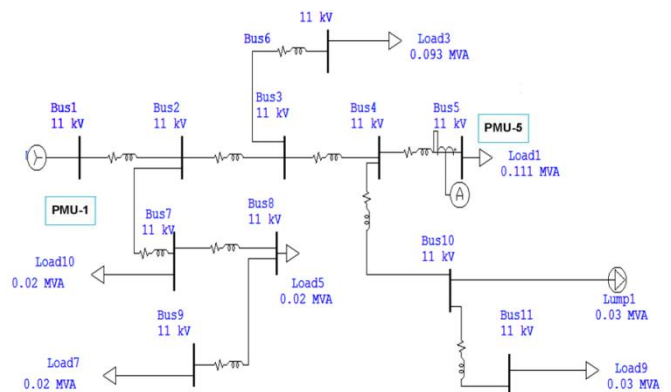

Fig. 1. Single-line diagram of 11-bus distribution feeder

Recent developments in synchrophasor measurement technology have prompted utilities to deploy it in the power system networks for wide area monitoring applications such as fault detection [2]. Locating a fault in distribution systems using minimum synchrophasor measurements is the main objective of this paper.

2. Observability - Optimal Placement Problem

Observability in power system refers the fact that measurement sets and their distribution are sufficient enough to solve the current status of power systems. In this section some other terminologies related with Observability is detailed, that will be used in this paper [4][9].

- A bus is said to be directly observable if one PMU is placed and the voltage magnitude and angle are measured.
- A calculated bus is said to be observable by other PMUs, but does not have a PMU in that bus.
- A bus is said to be unobservable, if it cannot be calculated due to one or more unavailable parameters.
- A system is said to be completely observable where all the buses are either directly observed or calculated.
- Incomplete observable system points to a system where some buses are not observed.

- If a smallest possible set that still provides full observability, then that minimal placement set is said to be the optimal set.

Placing a PMU at all substations will certainly provide all the real-time voltage magnitudes and angles for power system observability; anyway this is not required due to an important property of PMU. The knowledge of magnitude and angle of a bus, all current phasors, and the line parameters of the power system, then the voltage and angle of all connected bus can be calculated [4]. By ohm's law, if the voltage phasor at bus A is known, then the voltage at bus B will be the voltage at bus A minus the voltage drop caused by the current flowing through the transmission line. This is the first rule for observability, all buses connected to a bus that is directly observable then those buses are observable themselves, as illustrated in Fig. 2.

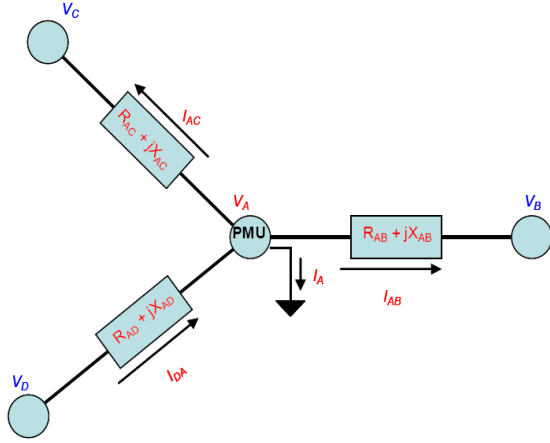

Fig. 2. Four bus system V_A , I_A , I_{AB} , I_{AC} & I_{AD} are known

$$V_B = V_A - I_{AB}(R_{AB} - jX_{AB}) \quad (1)$$

$$V_C = V_A - I_{AC}(R_{AC} - jX_{AC}) \quad (2)$$

$$V_D = V_A + I_{DA}(R_{AD} - jX_{AD}) \quad (3)$$

This will cause significant reduction in number of PMUs (and therefore cost) required for complete observability. Similarly for a seven bus system, can be made fully observable by keeping PMU's at bus-2 and bus-4 as shown in Fig. 3.

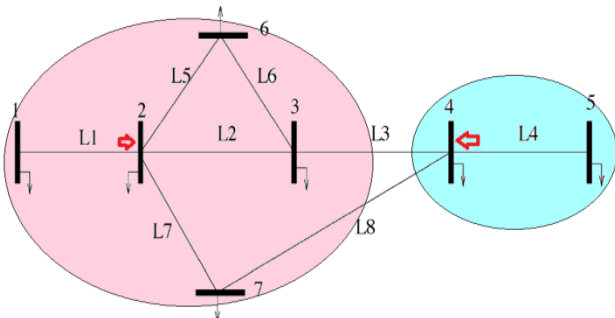

Fig. 3. Optimal PMU placement for seven bus system

3. Binary Search Algorithm

The minimum number of PMUs needed to make a system observable is found by using a binary search algorithm. The algorithm is exhaustive in the sense that it examines all possible combinations of locations before arriving at the minimum number of PMU's [5]. The formulation of problem is shown in Fig.4 solely considering PMU.

Step-1: Formation of Binary Connection Matrix (A_{km})

In order to form the constraint set, the binary connectivity matrix A_{km} , whose entries are defined below, will be formed first:

$$A_{km} \begin{cases} 1 & \text{if } k = m \text{ or } k \text{ and } m \text{ are connected} \\ 0 & \text{otherwise} \end{cases} \quad (4)$$

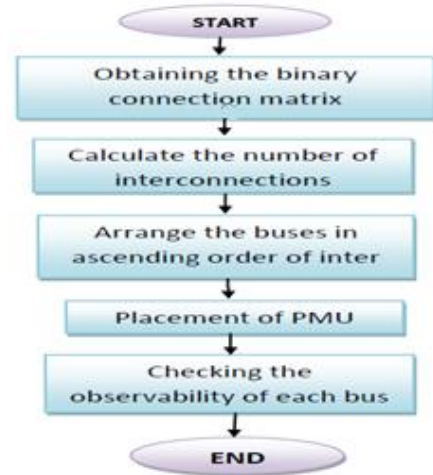

Fig. 4. Binary search algorithm-flow chart

Step-2: Calculate the number of interconnections

From the interconnection matrix the number of interconnections is calculated by adding the no '1' present in each column and hence this matrix will be an $N \times 1$ matrix.

Step-3: Arrange in ascending order of interconnections

This will be an $N \times 2$ matrix where the buses are arranged in descending order of interconnections. The first column will be the address of the bus and second column will be the number of interconnections arranged in descending order.

Step-4: PMU Placement and Observability checking

Here, the observability constraint for the i^{th} bus is given by

$$\sum_{j=1}^N A_{ij} x_j \geq 1 \quad (5)$$

Where A_{ij} = Interconnection Matrix

$$x_i = \begin{cases} 1 & \text{if PMU is installed at bus } i \\ 0 & \text{otherwise} \end{cases} \quad (6)$$

This also will be an $N \times 1$ matrix and can tell a

system to be observable if all the elements in this matrix are equal to or greater than one. The proposed algorithm is tested for standard IEEE 7, 14 & 30 bus systems. The results are given in table 1.

Table 1 – Optimal placement results

Test System	No of PMU's	Location
7 Bus	2	2,4
14 Bus	4	2,9,6,7
30 Bus	10	2, 4, 6, 9, 10, 12, 15, 18, 25, 27

4. Fault Location for Radial Systems

The diagnosis scheme and fault location algorithm is capable of identifying the location of a fault upon its occurrence in radial power distribution systems. This will be based on the integration of information available from PMU measurements with information contained in the distribution feeder database [7][9]. The proposed fault location method consists of two steps which will be running simultaneously, to find the actual fault location. In the first step, candidate locations are found using synchrophasors measured at one terminal by iterating every line segment. The outcome of this will be a set of candidate locations. In the second step, the another set of candidate locations are obtained by comparing the voltage phasors for the junction nodes of branches which are calculated using synchrophasors measured from two terminals. From these two possible candidate location sets, the actual fault point is determined. The flow representation of the same is displayed in Fig. 5.

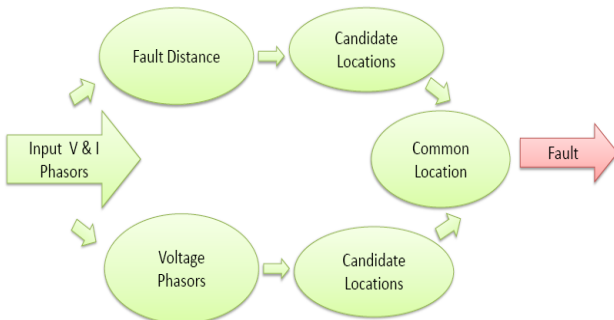

Fig. 5. Proposed work – flow representation

An 11-bus feeder system shown in Fig. 1 is used to illustrate this method. This feeder has a main circuit, three lateral branches, one generator connected at bus-1 and seven static loads connected at different buses as shown in Fig. 1. Two PMUs, installed at bus-1 and bus-5, provide synchronized voltage and current phasor measurements. The network topology, line parameters, and load models are known.

A. Candidate Locations Based on Fault Distance

The fault distance method is based on the iterative solution of the equations which describe the steady-state fault condition. To illustrate the process, consider a single-line-to-ground fault on phase A, as shown in Fig. 6, where voltages and currents at the sending-end of the faulted line segment are known from the PMU

located at that bus [1][3].

$$V_a = D(Z_{aa}I_a) + (I_f R_f) \quad (7)$$

Where,

D = fault distance

I_f = fault current

R_f = fault resistance

In order to calculate the fault distance, the following iterative approach is applied to solve these equations:

1. The iteration begins by assuming an initial fault current I_f reasonable estimate is given by

$$I_f = I_a - I_{a_{pre}} \quad (8)$$

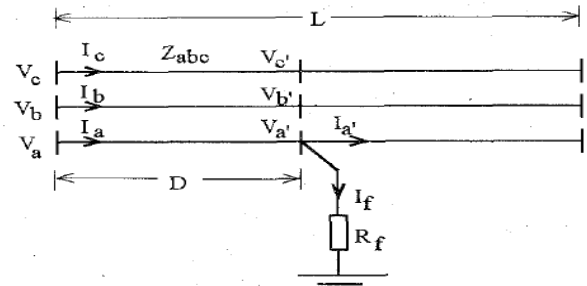

Fig. 6. Fault on phase A

Where, $I_{a_{pre}}$ is the pre-fault current on the faulted phase.

2. With the known fault current, the fault distance and the fault resistance can be calculated by separating equation (7) into the real part and the imaginary part and then solving the two resulting real equations.
3. Once the calculated fault distance is known, the voltage vector at the fault point is calculated.

Based on these fault distance different candidate locations are obtained and saved aside.

B. Candidate Locations Based on Voltage Phasors

The voltage phasors designated as V_2^1 and V_3^1 with the superscript representing the bus, from which the phasor is measured, are calculated. V_2^1 corresponds to the junction of bus-2 on the main circuit and V_3^1 corresponds to the junction bus-3 of the main circuit [2].

To eliminate the non-faulted lines, voltage and current phasors measured at bus-5 are used to calculate the voltage phasors for bus-2 and bus-3, as shown in Fig. 1. To illustrate this process consider a symmetrical fault at bus- 8 as shown in Fig - 7. For location F_8 (fault at bus-8) voltage phasors at bus-2, denoted as V_2^1 and V_2^5 , are calculated from bus-1 and bus-5, respectively, as if there is not a fault at bus 8. If $|V_2^1 - V_2^5| \leq \epsilon$ where ' ϵ ' is a predefined threshold, then we can say that the fault is at bus-2 or in any of the bus which are directly associated with the bus 2 [2]. Otherwise, it is removed from the candidate list. The voltage difference is measured by total vector error (TVE). Similarly, for a fault at bus 11 as shown in Fig.8, can be removed by

using calculated voltage V_4^1 and V_4^5 .

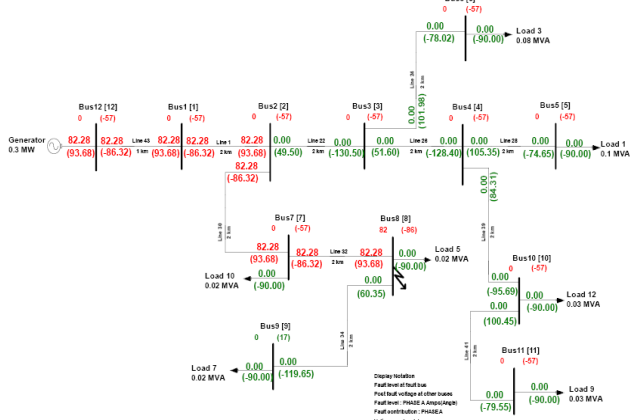

Fig. 7. Fault on bus – 8

In this manner another set of candidate locations will be obtained for each case. From these two sets of candidate locations the common buses will be taken out and considered as the faulted location.

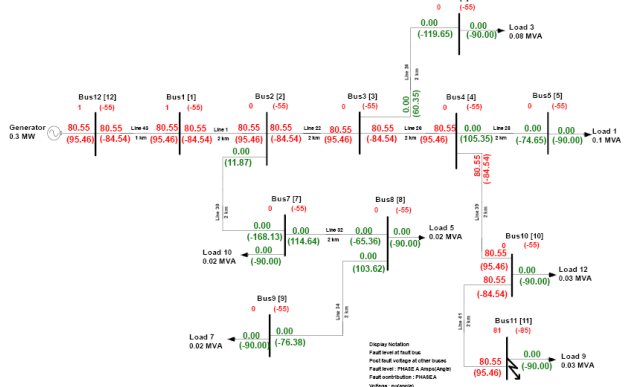

Fig. 8. Fault on bus – 11

In case, if the fault is happening at the main feeder itself, which is at bus 1,2,3,4 & 5, then the fault can be easily located by checking the voltage phasor collected for the remote end that is from the PMU-5. The flow diagram of the proposed algorithm is detailed in the Fig.9.

Table 2 – Case study results

Faulted Bus	Fault Distance (kMs)	Candidate Locations Based on Fault Distance	Candidate Locations Based on Phasor Comparison	Common location-FAULT BUS
Bus 8	6.03	Bus6, Bus8 , Bus4	Bus7, Bus8 , Bus9	Bus 8
Bus 6	6.02	Bus6 , Bus8, Bus4	Bus-6	Bus 6
Bus 9	8.1	Bus5, Bus9 , Bus10	Bus7, Bus8 , Bus9	Bus 9
Bus 11	10.15	Bus11	Bus10, Bus11	Bus 11
Bus 2	1.999	Bus2	NA($V_5=0$)	Bus 2
Bus 5	7.994	Bus5	NA($V_5=0$)	Bus-5

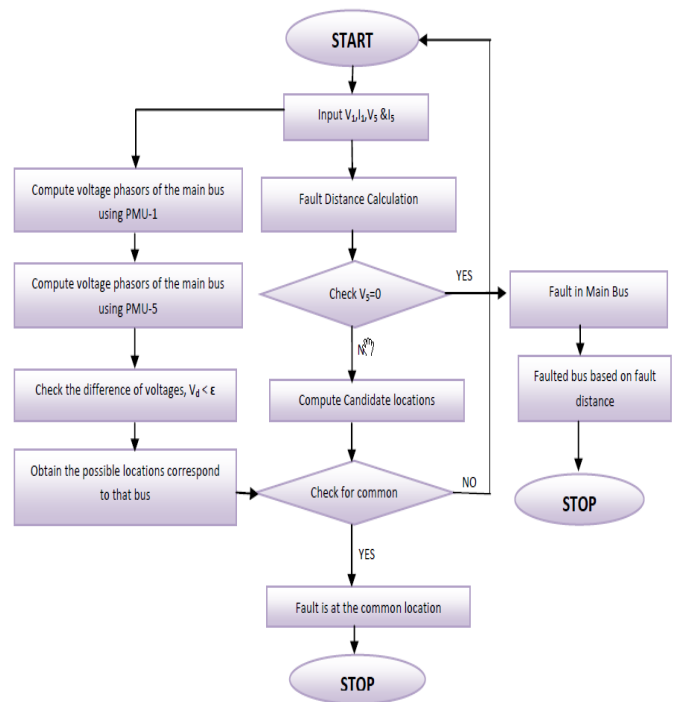

Fig. 9. Fault detection flow chart

The proposed method is tested for six different fault cases for the system given in Fig. 1. and the corresponding results are tabulated in table 2. It is observed that the proposed scheme is able to give results within 2% accuracy of the line length.

5. Fault Location for Ring Systems

The proposed fault location method for ring system consists of three steps which will be running simultaneously. In the first step, the fault distance is calculated based on the synchrophasor data available from the PMU located at one end of the feeder. In the second step, the bus associated with fault location in the main network is calculated based on the synchrophasor data available from the PMU's located at both the ends of the feeder. The third step involved in the proposed scheme is the calculation of the fault distance in the sub feeder. For fault distance calculation, synchrophasor data available from the PMU's located at both the ends of the ring feeder are utilized. The flow representation of the proposed fault location algorithm is shown in fig. 10.

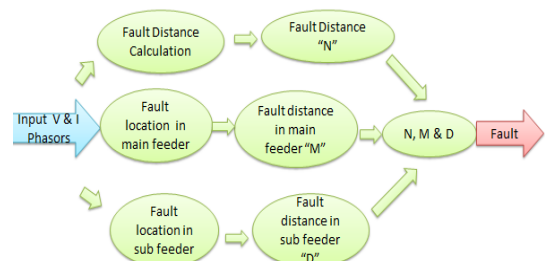

Fig. 10. Proposed work – flow representation

An 11-bus feeder system shown in fig. 11 is used to illustrate this method in radial system. This feeder has a main circuit, three lateral branches, one generator connected at bus-1 and seven static loads connected at different buses as shown in fig. 11. Two PMUs, installed at bus-1 and bus-5, provide synchronized voltage and current phasor measurements.

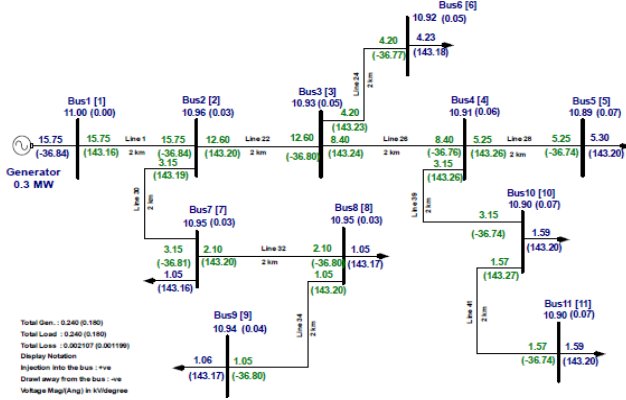

Fig. 11. Load flow in 11 bus radial feeder

A 14-bus feeder system is used to illustrate the proposed fault location method in ring system. Load flow analysis of the 14 bus system is shown in fig. 12. This feeder has a main circuit, three lateral branches, two generators connected at bus-1 & bus-5. Five static loads connected at different buses as shown in fig. 12. Two PMUs, installed at bus-1 and bus-5, provide synchronized voltage and current phasor measurements. The network topology, line parameters, and load models are known.

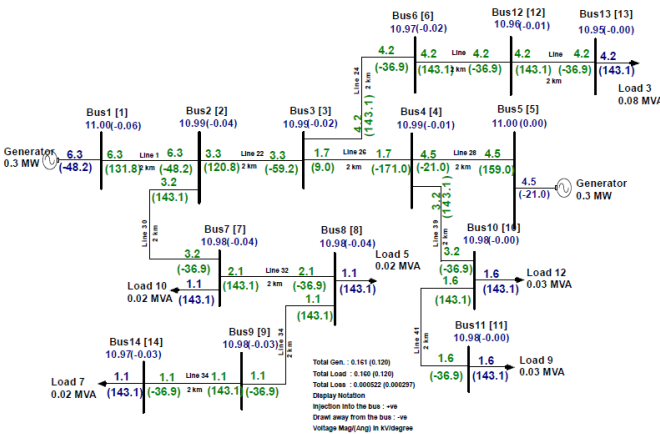

Fig. 12. Load flow in 14 bus ring system

Step 1-Fault distance calculation

This step is similar to the step 1 in radial system. The fault distance method is based on the iterative solution of the equations which describe the steady-state fault condition. To illustrate the process, consider a single-line-to-ground fault on phase A, as shown in fig. 13, where voltages and currents at the sending-end of the faulted line segment are known from the PMU located at that bus [1][4].

$$V_a = D(Z_{aa}I_a) + (I_f R_f) \quad (9)$$

Where,

D = fault distance

I_f = fault current

R_f = fault resistance

In order to calculate the fault distance, the following iterative approach is applied to solve this equation [2]:

1. The iteration begins by assuming an initial fault current I_f reasonable estimate is given by

$$I_f = I_a - I_{a\text{pre}} \quad (10)$$

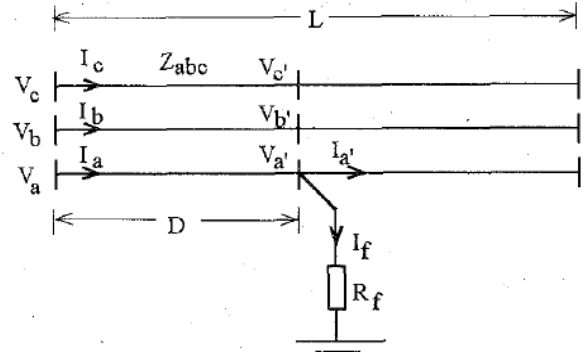

Fig. 13. Fault on phase A

Where, $I_{a\text{pre}}$ is the pre-fault current on the faulted phase.

2. With the known fault current, the fault distance and the fault resistance can be calculated by separating (10) into the real part and the imaginary part and then solving the two resulting real equations.
3. Once the calculated fault distance is known, the voltage vector at the fault point is calculated.

In the proposed algorithm this fault distance will be calculated in kilometers and denoted as 'N'. Load flow analysis and short circuit study results are used here for the calculations.

Step 2-Finding the bus associated with fault location in the main network.

As shown in fig. 13, the fault is at location m [per unit] of the main network from Bus G and $(1-m)$ [per unit] from Bus H. The voltage of the bus associated with the fault is denoted as V_F , and the bus voltages and currents are as indicated in the figure. Use of voltage/current yields the results found in (11) & (12):

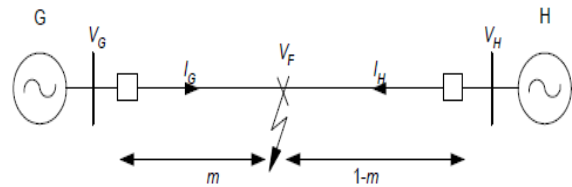

Fig. 14. Fault on doubly fed system

$$V_G = mZI_G + V_F \quad (11)$$

$$V_H = (1-m)ZI_H + V_F \quad (12)$$

Subtracting the two equations to eliminate the unknown V_F results in (13):

$$V_G - V_H = mZI_G + (m-1)ZI_H \quad (13)$$

Where,

V_G = Terminal voltage of generator G

V_H = Terminal voltage of generator H

I_G = Current contribution from generator G

I_H = Current contribution from generator H

Z = Per km impedance of the feeder

Fault distance 'm' can be found out by solving (13) and the phase values can be substituted with the symmetrical components. Multiplying 'm' with the total distance of the main feeder will give the actual distance 'M'. This will be the distance from PMU-1 to the bus associated with the fault.

Step 3-Fault distance calculation in the sub feeder

The methodology followed here is same as that in the step -1. The only difference is that, here the fault distance calculated will be the distance of the fault from the bus associated with fault in the main network. This fault distance will be calculated in kilometers and denoted as 'D'. The result of short circuit study carried out for the fault at bus-8 in a radial feeder is shown in fig. 15 [1].

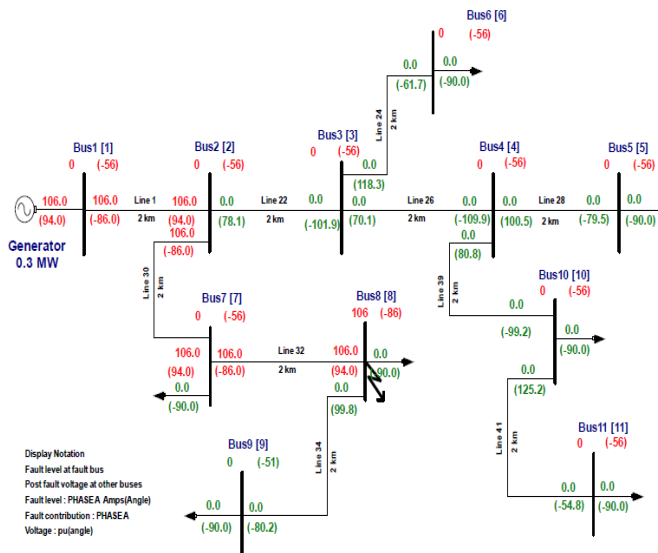

Fig. 15. Fault on bus 8 in 11 bus radial system

Depends on M, N & D, the algorithm will decide the fault is on main feeder or sub feeder. If $M=N$, then the fault is in main bus and the fault distance can be given as M kms. If $M \neq N$, the fault is in the sub feeder and the fault distance can be given as (M+D) kms. The result of short circuit study carried out for the fault at bus-12 and bus-3 are shown in fig.16 and fig.17 respectively in a ring feeder. The flow diagram of the proposed

algorithm is detailed in the fig.18.

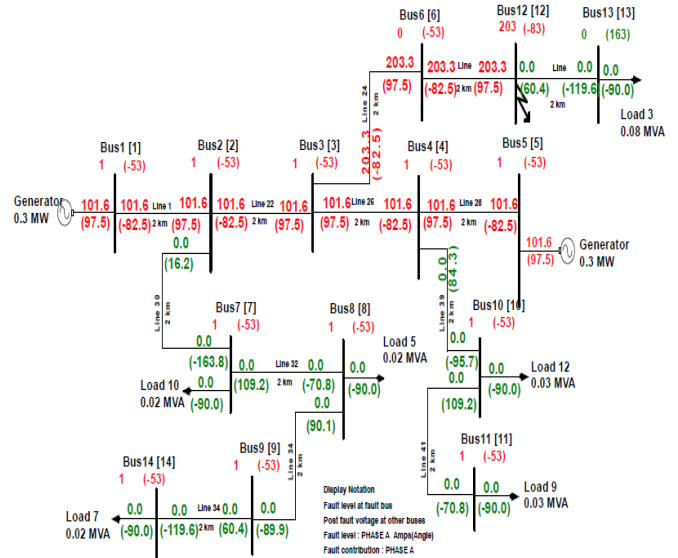

Fig. 16. Fault on bus 12 in 14 bus ring system

The proposed algorithm is tested for four different faults in an 11 bus test system and another four different faults in a 14 bus system. These test cases include faults in main feeder as well as fault in sub feeders.

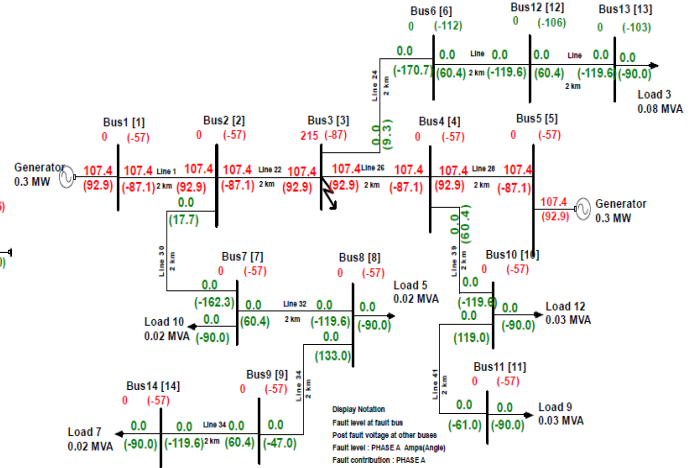

Fig. 17. Fault on bus 3 in 14 bus ring system

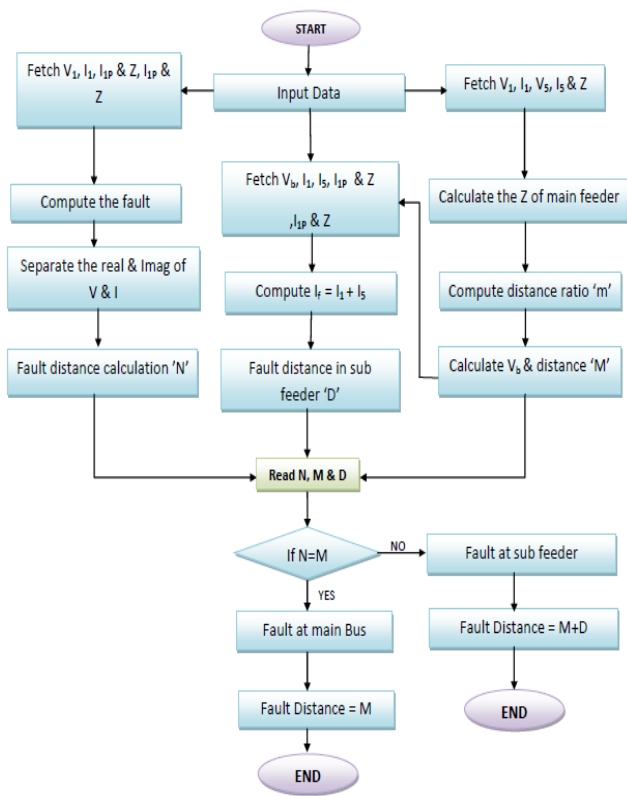

Fig. 18. Fault detection flow chart

The proposed method is tested for eight different fault cases for the ring and radial systems and the corresponding results are tabulated in table 3 & 4.

Table 3 – Case study results for 11 bus radial system

Faulted Bus	Fault Distance based on PMU 1 (N*)	Bus associated with fault location in the main network (M*)	Distance in the sub feeder (D*)	Condition	Fault Bus & Distance*
Bus 8	8	2	4	$N \neq M$	Bus 8 (6)
Bus 9	11	2	6	$N \neq M$	Bus 9 (8)
Bus 11	14	6	2	$N \neq M$	Bus 11 (8)
Bus 2	2	2	0.07	$N = M$	Bus 2 (2)

*Distance in km

Table 4 – Case study results for 14 bus ring system

Faulted Bus	Fault Distance based on PMU 1 (N*)	Bus associated with fault location in the main network (M*)	Distance in the sub feeder (D*)	Condition	Fault Bus & Distance*
Bus 8	6	2	4	$N \neq M$	Bus 8 (6)
Bus 12	17	2	6	$N \neq M$	Bus 9 (8)
Bus 11	9	6	2	$N \neq M$	Bus 11 (8)
Bus 3	4	4	0.21	$N = M$	Bus 2 (4)

*Distance in km

6. Case Studies

Ring Feeder – IISc Bangalore Feeder

IISc Bangalore is having a dedicated 66/11 kV substation to feed a load of 10 MVA in Indian Institute of Science, Bangalore as shown in fig. 14. A ring feeder from this distribution substation was chosen as a case study for testing the proposed algorithm. This feeder has 11 buses and 8 distribution transformers with a total connected load of 10 MVA. Symmetrical faults were created at three different locations to test the proposed scheme. For all these test cases the algorithm was giving a result within 98 % accuracy of the line length.

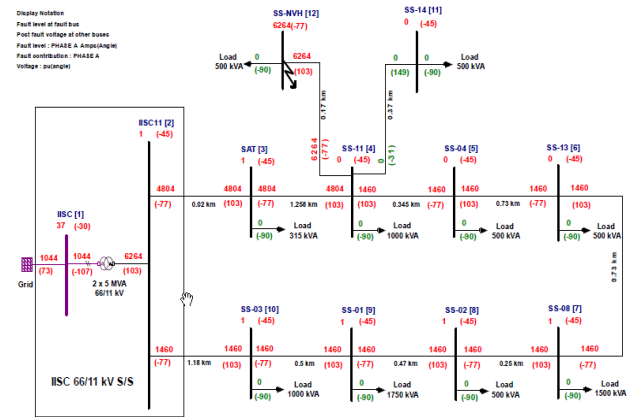

Fig. 19. Fault on IISc Bangalore ring feeder

Radial Feeder 1 - Amritapuri Ochira Feeder

Ochira is a 33kV distribution substation which is having a connected load of 15 MVA as shown in fig. 12. A radial feeder from this distribution substation was chosen as a case study for testing the proposed algorithm. This feeder has 23 buses and 22 distribution transformers with a total connected load of 3 MVA. Out of these 22 transformers, 2 are dedicated transformers. Symmetrical faults were created at three different locations to test the proposed scheme. For all these test cases the algorithm gave a result within 98 % accuracy of the line length.

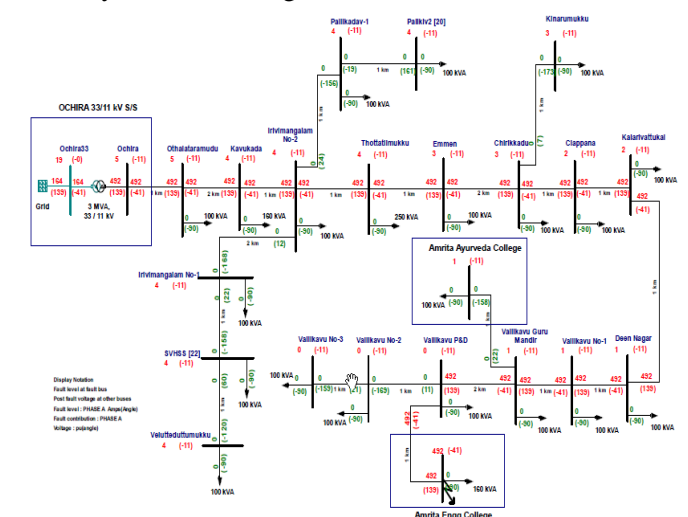

Fig. 20. Fault on Ochira Amritapuri radial feeder

Radial Feeder 2 –Karunagapally Urban Feeder

Karunagapally is a 33kV distribution substation which is having a connected load of 10MVA as shown in fig. 13. A radial feeder from this distribution substation was chosen as a case study for testing the proposed algorithm. This feeder has 16 buses and 14 distribution transformers with a total connected load of 4.5MVA. This feeder is mainly feeding the urban load in Karunagapally town. Symmetrical faults were created at two different locations to test the proposed scheme. For all these test cases the algorithm was giving a result within 98 % accuracy of the line length.

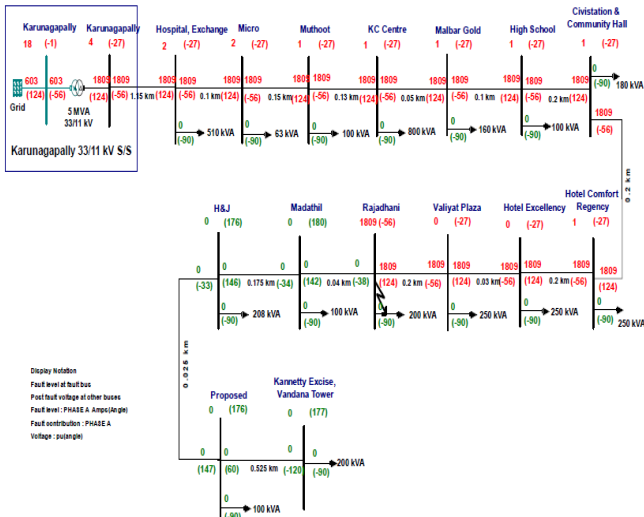

Fig. 21. Fault on Karunagapally Urban radial feeder

7. Conclusions

A program was developed using Binary Search Algorithm and is tested for different bus systems. It is observed that PMU placement problem does not have a unique solution. Depending upon the starting point, the developed optimization scheme may yield different sets of optimal solutions, each one providing the same minimum number of PMUs but at different locations.

The proposed method for accurately locating faults in distribution system uses synchrophasor measurements from multiple locations to pinpoint the faulted line. The same is tested for eight different fault cases for the ring and radial test systems. The scheme is also validated for different power distribution networks (ring & radial). The processing time for the proposed scheme is 0.36 seconds with the system configuration-Core 2 Duo, 2.79 GHz processor and 2 GB RAM. It is observed that the proposed scheme is able to give results within 98% accuracy of the line length.

References

- [1] Aneesh Rajeev, Angel T.S and Faraz Zafar Khan, "Fault Location in Distribution Feeders with Optimally Placed PMU's," in *Proc.IEEE-2015 International Conference on Technological Advancements in Power and Energy*, Amrita VishwaVidyapeetham, Amritapuri, 24 -26 June, 2015, Kollam, India.
- [2] J. Zhu, D. L. Lubkeman, and A. A. Girgis, "Automated fault location and diagnosis on electric power distribution feeders," *IEEE trans. Power Del.*, vol. 12, no. 2, pp. 801–809, Apr. 1997.
- [3] J. Ren, S. S. Venkata, and E. Sortomme, "An Accurate Synchrophasor Based Fault Location Method for Emerging Distribution Systems", *IEEE trans on Power Delivery*, vol. 29, no. 1, pp. 297-300, Feb 2014.
- [4] J. Mora-Florez, J. Melendez, and G. Garrillo-Caicedo, "Comparison of impedance based fault location methods for power distribution systems," *Elect. Power Syst. Res.*, vol. 78, no. 4, pp. 657–666, Apr. 2008.
- [5] B. Xu and A. Abur, Optimal Placement of Phasor Measurement Units for State Estimation, *PSERC Final Report, PSERC Publication 05-58*, Oct. 2005.
- [6] R. Kavasseri and S. Srinivasan, "Joint optimal placement of PMU and conventional measurements in power systems," in *Proc. 2010 IEEE Symp. Circuits and Systems*, Paris, France, Jun. 2010.
- [7] R. Kavasseri and S. Srinivasan, "Joint optimal placement of PMU and conventional measurements in power systems," *IEEE Trans on Power Systems*, Vol. 26, No. 4, pp. 1929–1936, November 2011.
- [8] V.K.Agrawal, P.K.Agarwal, Rajesh Kumar, Manager, "Experience of commissioning of PMUs Pilot Project in the Northern Region of India", Feb 2010.
- [9] Aneesh Rajeev, Angel T.S and Faraz Zafar Khan, "Optimally Placed PMU's for Fault Detection in Distribution Network," in *Proc. IEEE Int. Conf. Electrical, Electronics, Signals, Communication and Optimization*, Visakhapatnam, India, Jan 24-25, 2015.